



US 20090020580A1

(19) **United States**

(12) **Patent Application Publication**
Tate

(10) **Pub. No.: US 2009/0020580 A1**

(43) **Pub. Date: Jan. 22, 2009**

(54) **BACKPACK SYSTEMS**

Publication Classification

(76) Inventor: **Aarn Tate**, Christchurch (NZ)

(51) **Int. Cl.**
A45F 3/04 (2006.01)

Correspondence Address:
Stoneman Volk Patent Group
3770 NORTH 7TH STREET, Suite 100
PHOENIX, AZ 85014 (US)

(52) **U.S. Cl.** 224/637

(57) **ABSTRACT**

(21) Appl. No.: **12/174,589**

Backpack and counterbalance systems using load balancing pockets to be worn during active movement. The load balancing pockets of such system are arranged in the following way: a gap is created between the pockets so that the feet of the wearer are visible through the gap; the sides of the pockets do not hinder the natural swing of the arms when walking or running; this positioning is maintained whatever the size and shape of the wearer.

(22) Filed: **Jul. 16, 2008**

(30) **Foreign Application Priority Data**

Jul. 16, 2007 (NZ) 556509

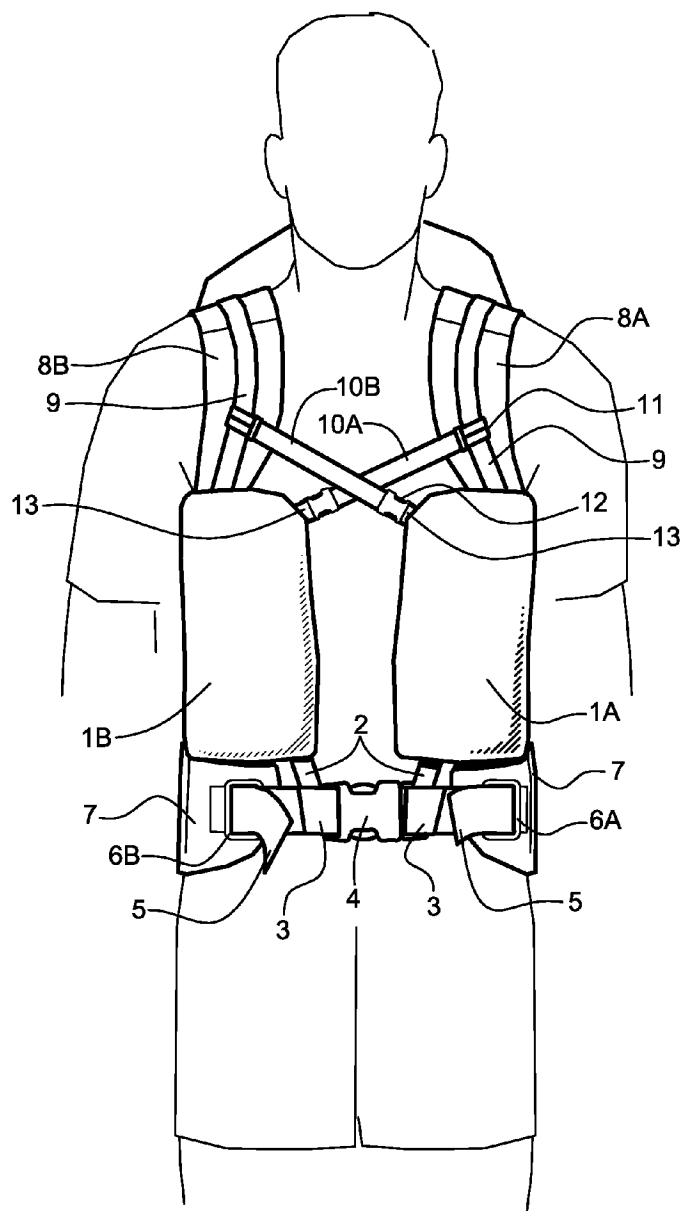

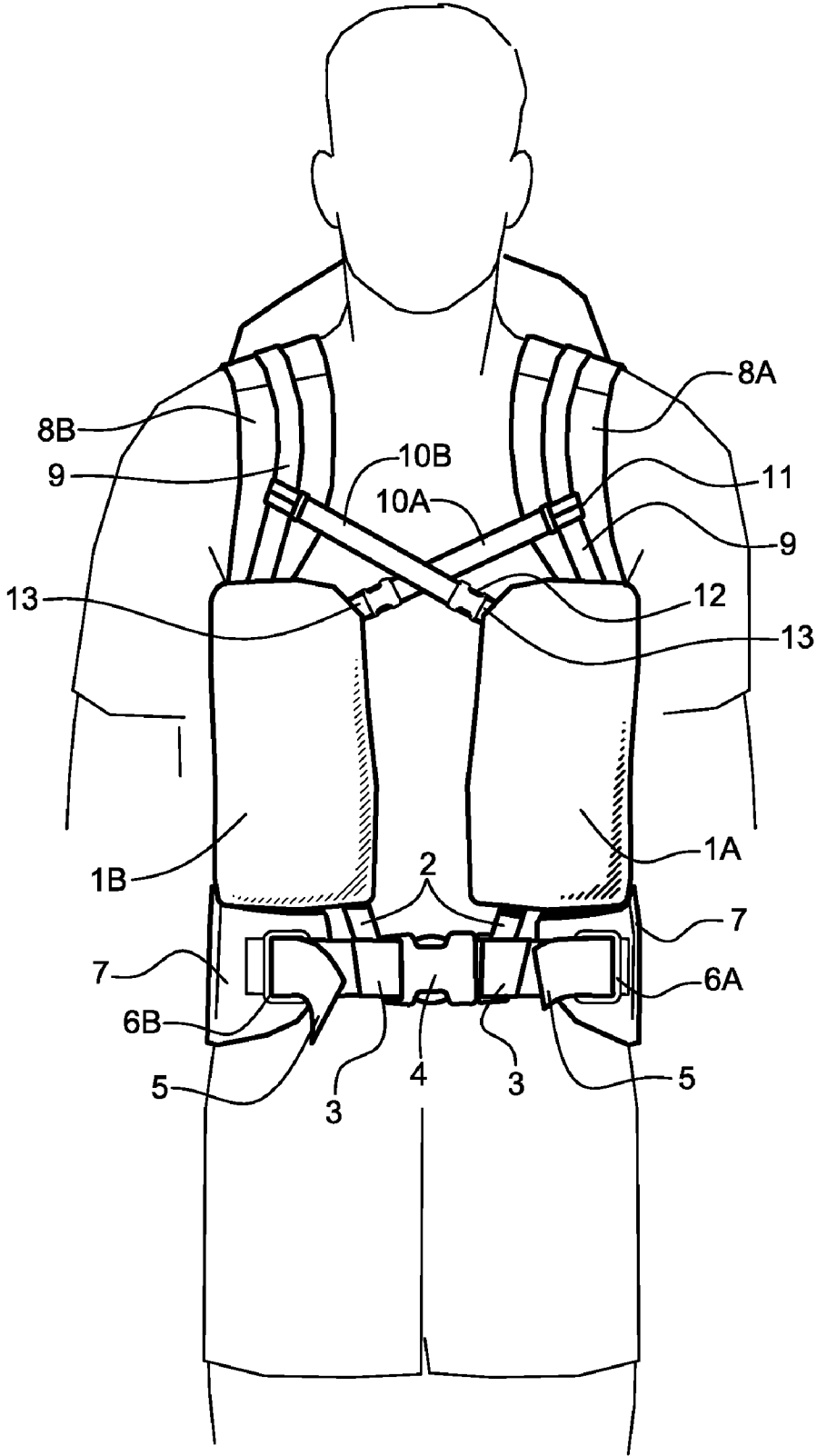

FIG. 1

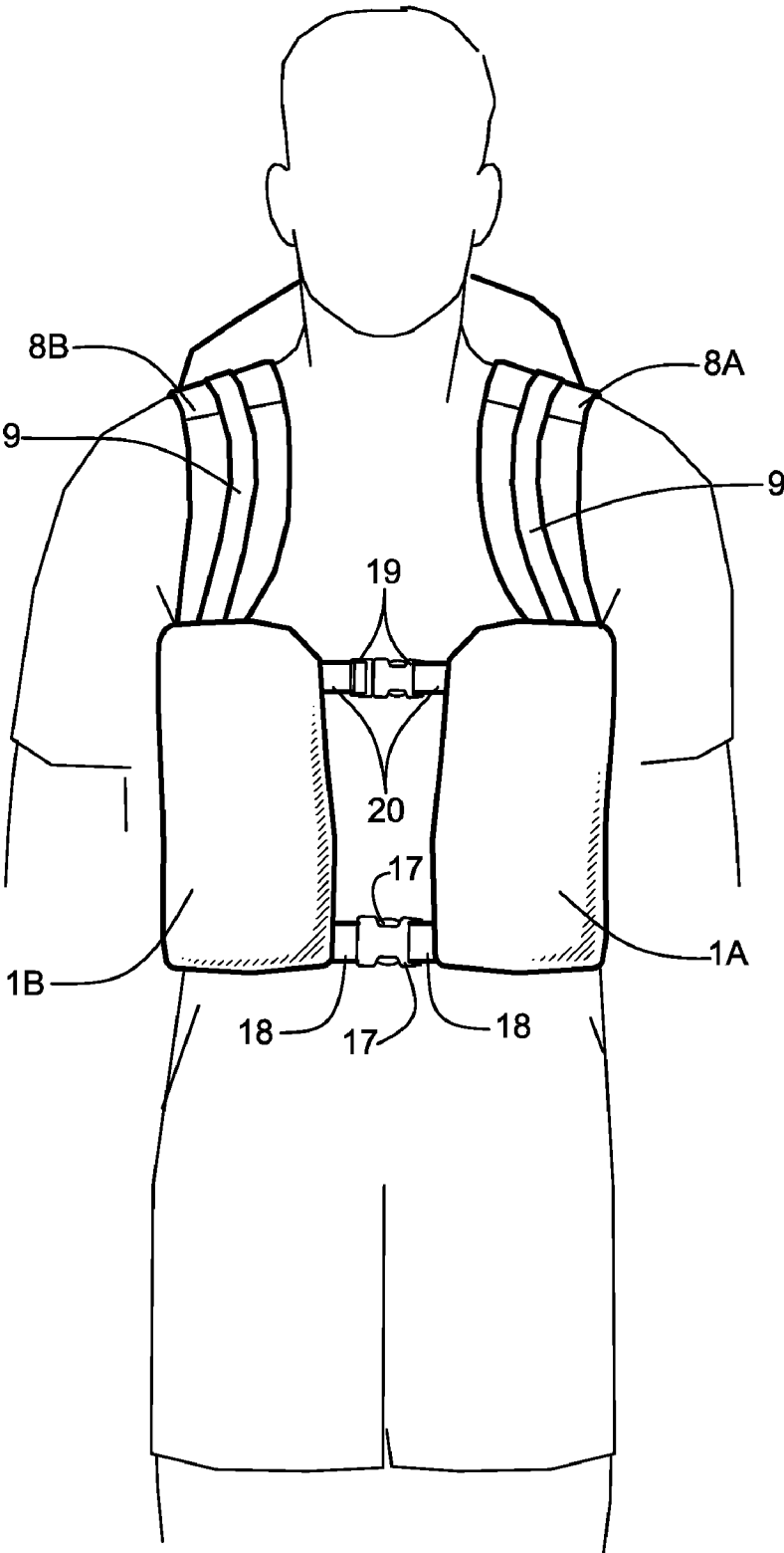

FIG. 2

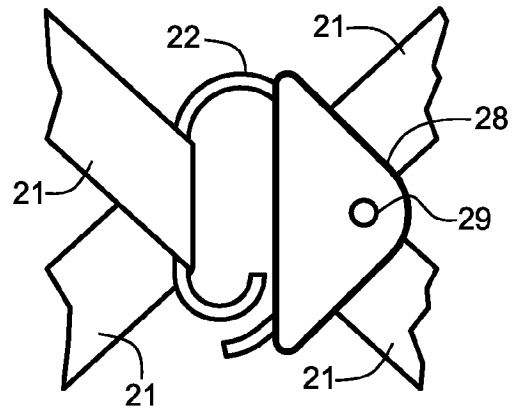
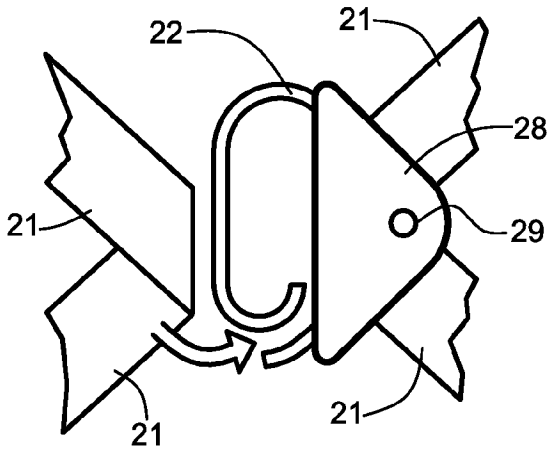
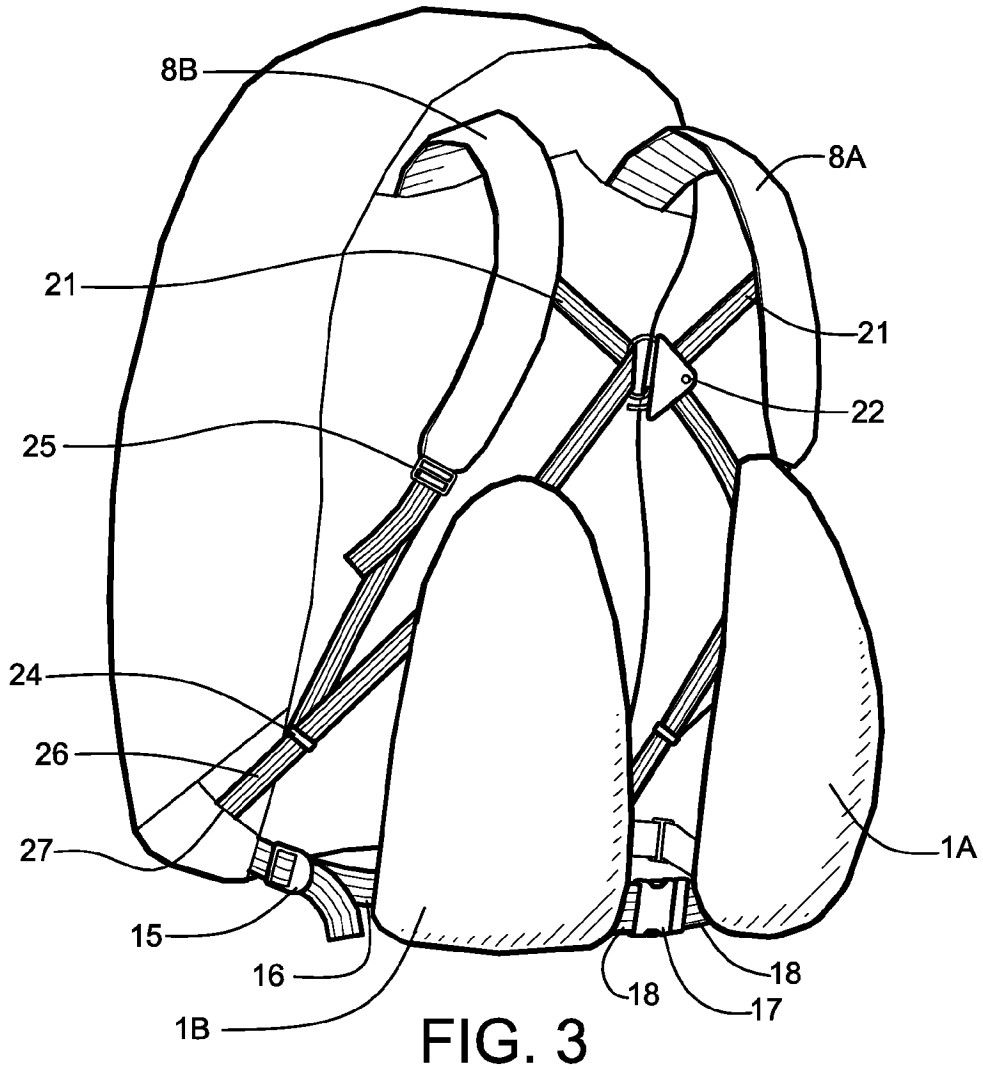

FIG. 4A

FIG. 4B

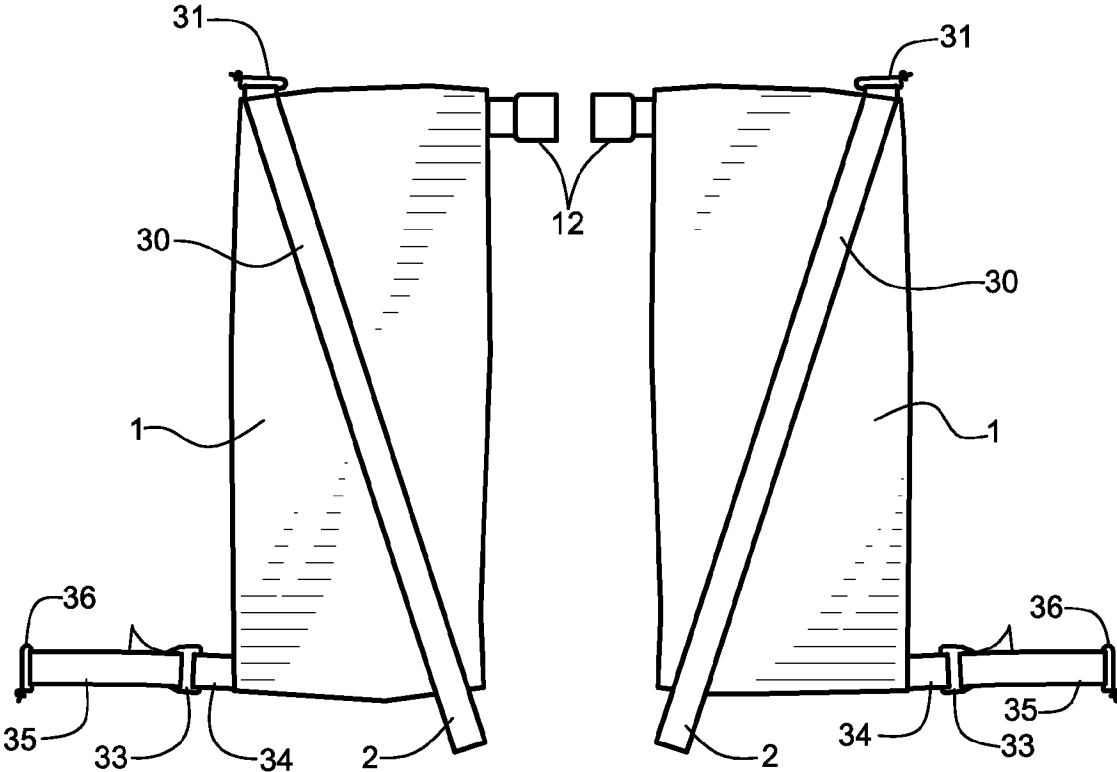

FIG. 5

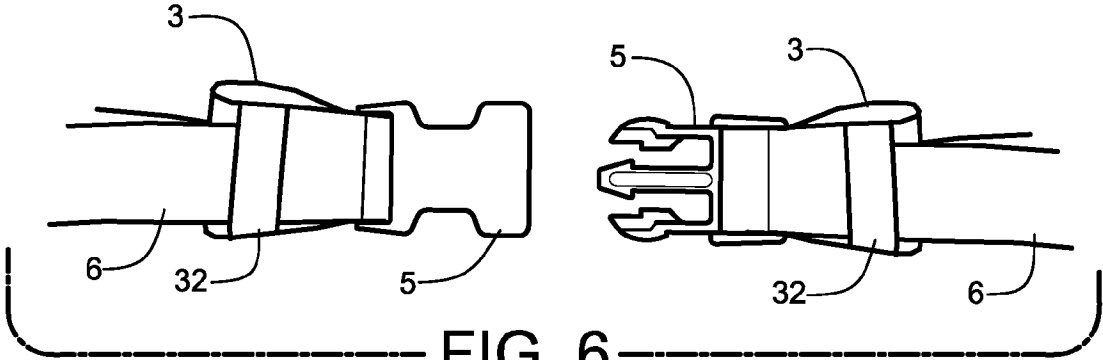

FIG. 6

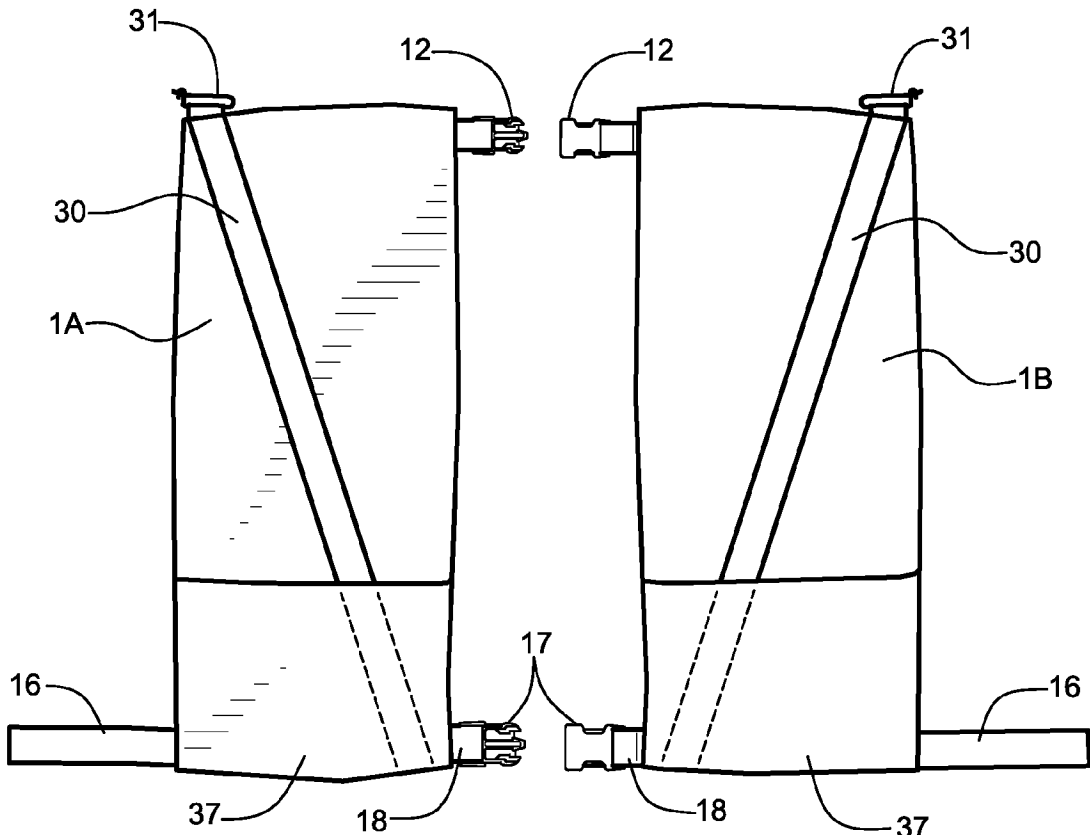

FIG. 7

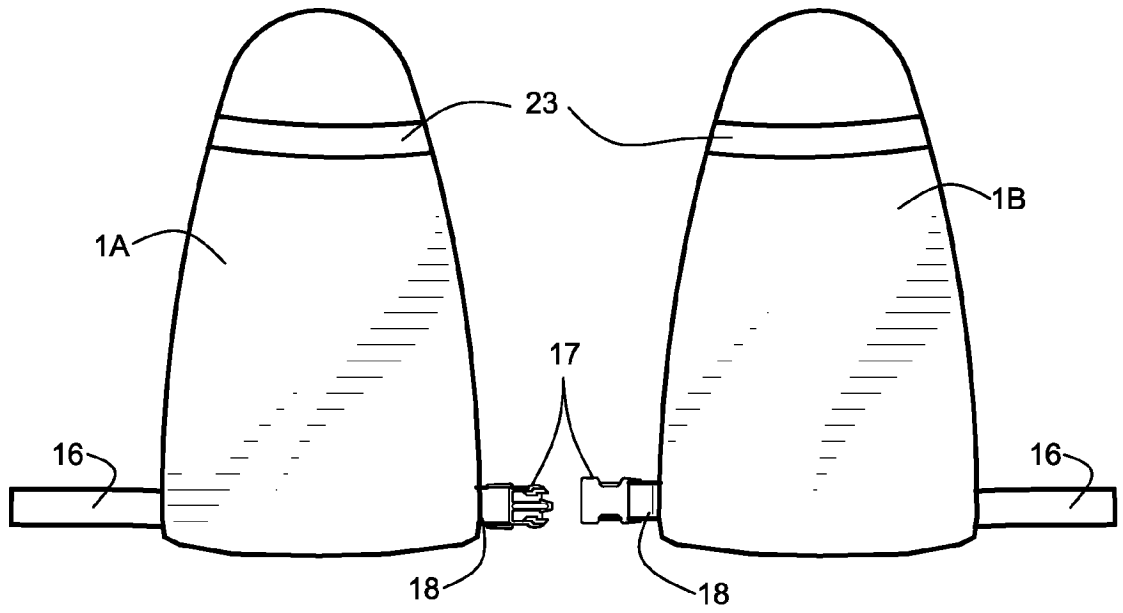

FIG. 8

BACKPACK SYSTEMS

CROSS-REFERENCE TO RELATED APPLICATION

[0001] The present application is related to and claims priority from prior New Zealand Patent Application No. 556,509, filed Jul. 16, 2007, entitled "COUNTER BALANCE POCKETS FOR BACKPACKS", now New Zealand Patent No. 556509, the content of which is incorporated herein by this reference and is not admitted to be prior art with respect to the present invention by the mention in this cross-reference section.

BACKGROUND

[0002] This invention relates to backpack systems in general and more particularly to backpacks comprising counterbalancing systems.

[0003] When individuals wear backpacks and carry a load, proper alignment and proper range of motion during movement is important to avoid injury.

[0004] No system exists that provides a counterbalancing load carrying system that is very stable under active movement, does not restrict movement, and positions the pockets in the following way: a gap is created between the pockets so that the feet of the wearer are visible through the gap; the sides of the pockets do not hinder the natural swing of the arms when walking or running; and that this positioning is maintained whatever the size and shape of the wearer.

[0005] Therefore, a need exists for such a system that provides an improved counterbalancing load carrying system that is very stable under active movement, does not restrict movement, and positions the pockets in the following way: a gap is created between the pockets so that the feet of the wearer are visible through the gap; the sides of the pockets do not hinder the natural swing of the arms when walking or running; and that this positioning is maintained whatever the size and shape of the wearer.

OBJECTS AND FEATURES OF THE INVENTION

[0006] A primary object and feature of the present invention is to provide a system overcoming the above-mentioned problem and meeting the above-mentioned needs.

[0007] It is a further object and feature of the present invention to provide such a system that is very stable under active movement. A further object and feature of the present invention is to provide such a system that does not restrict movement. Still a further object feature of the present invention is to position the pockets of such system in the following way: a gap is created between the pockets so that the feet of the wearer are visible through the gap; the sides of the pockets do not hinder the natural swing of the arms when walking or running; and that this positioning is maintained whatever the size and shape of the wearer.

[0008] A further primary object and feature of the present invention is to provide such a system that is efficient, inexpensive, and handy. Other objects and features of this invention will become apparent with reference to the following descriptions.

SUMMARY OF THE INVENTION

[0009] In accordance with a preferred embodiment hereof, this invention provides a backpack and counterbalancing system comprising: at least one backpack body, having at least

one lower portion, to be worn on a back of a wearer; at least one shoulder harness having at least one left shoulder strap and at least one right shoulder strap; at least one left side pocket to be worn in front of the wearer; wherein such at least one left side pocket comprise at least one upper portion, at least one lower portion, and at least one rear panel; wherein such at least one upper portion of such at least one left side pocket is operatively connected to such at least one left shoulder strap, and wherein such at least one lower portion of such at least one left side pocket is operatively connected, via at least one adjustable length connector, to at least one lower left side portion of such at least one backpack body to maintain such at least one left side pocket in general vertical alignment; at least one right side pocket to be worn in front of the wearer; wherein such at least one right side pocket comprises at least one upper portion, at least one lower portion, and at least one rear panel; wherein such at least one upper portion of such at least one right side pocket is operatively connected to such right shoulder strap and at least one lower portion of such at least one right side pocket is operatively connected via at least one adjustable length connector to the lower right side portion of such at least one backpack body to maintain the right side pocket in general vertical alignment; at least one separable link of fixed length operatively connecting such at least one left side pocket to such at least one right side pocket; and wherein such at least one rear panel of such at least one left side pocket and such at least one rear panel of such at least one right side pocket each comprise at least one frame extending from such at least one top portion of such at least one rear panel to such at least one bottom portion of such at least one rear panel of a respective side pocket.

[0010] Moreover, it provides such a backpack and counterbalancing system, wherein the connection of each side pocket to a corresponding shoulder strap is via at least one free sliding connection along the length of at least a lower portion of each such shoulder strap. Additionally, it provides such a backpack and counterbalancing system, further comprising at least one right chest strap; and at least one left chest strap; wherein such at least one right chest strap is slidably connected to, and along the length of, at least one lower portion of such at least one right shoulder strap; and wherein such at least one left chest strap is slidably connected to and along the length of at least one lower portion of such at least one left shoulder strap. Also, it provides such a backpack and counterbalancing system, further comprising at least one first separable link operatively connecting at least one upper portion of such at least one left side pocket to such at least one right shoulder strap; and at least one second separable link operatively connecting at least one upper portion of such at least one right side pocket to such at least one left shoulder strap.

[0011] In addition, it provides such a backpack and counterbalancing system, further comprising at least two separable links of fixed length operatively connecting such at least one left side pocket and such at least one right side pocket, a first separable link of such at least two separable links connecting such pockets at an upper portion, and a second separable link of such at least two separable links connecting such pockets at a lower portion. And, it provides such a backpack and counterbalancing system, further comprising at least one left chest strap and at least one right chest strap; wherein such at least one left chest strap is operatively connected to a middle portion of such at least one left shoulder strap, which passes through at least one loop attached to at least one lower

left side portion of such at least one backpack body, and further connects to a lower portion of such at least one left shoulder strap to form a continuous loop on the left side of such backpack; wherein such at least one right chest strap, wherein such at least one right chest strap is operatively connected to a middle portion of such at least one right shoulder strap, which subsequently passes through at least one loop attached to a lower right side portion of such at least one backpack body, and further connects to a lower portion of such at least one right shoulder strap to form a continuous loop on the right side of the backpack; and wherein such shoulder straps are freely moveable through such continuous loops to enable shoulder movement of the wearer.

[0012] Further, it provides such a backpack and counterbalancing system, wherein such chest straps are positioned adjacent to the upper chest of the wearer such that each strap runs diagonally downward from such middle portions of such shoulder straps towards the center of the chest of the wearer, and further down towards the corresponding hip of the wearer; and wherein each chest strap may be connected to the opposite chest strap via at least one separable link; such that the two chest straps when connected form an "X" configuration across the chest of the wearer. Even further, it provides such a backpack and counterbalancing system, wherein such at least one separable link comprises at least a one-part clip. Moreover, it provides such a backpack and counterbalancing system, wherein such at least one separable link comprises an elongated loop with at least one end open, wherein one side of such loop is slidably connected to at least one chest strap, and wherein the other chest strap may be inserted into the open end of such elongated loop to rest against the other side of such elongated loop and wherein the aforementioned other chest strap is free to slide around the side of the loop when the wearer twists shoulders relative to hips.

[0013] Additionally, it provides such a backpack and the counterbalancing system, wherein such chest straps are length adjustable; and adjusting such at least one left chest strap simultaneously tightens such at least one left shoulder strap and such at least one left chest strap, and adjusting such at least one right chest strap simultaneously tightens such at least one right shoulder strap and such at least one right chest strap. Also, it provides such a backpack, further comprising at least one hip/waist belt, and wherein lower portions of such pockets form a substantial part of such hip/waist belt. In addition, it provides such a backpack and counterbalancing system, further comprising at least one hip/waist belt, wherein lower side portions of such at least one backpack body comprise such at least one hip/waist belt. And, it provides such a backpack and counterbalancing system, wherein such at least one frame of each such pocket is positioned diagonally across the rear panel in a direction downwardly and inwardly from the outer upper corner of the rear panel such that a top end of such frame is adjacent to and operatively connectable with a corresponding shoulder strap and the other end of such frame is adjacent to a lower separable link to the other such pocket.

[0014] Further, it provides such a backpack and counterbalancing system, wherein such frame in each pocket is positioned diagonally across such at least one rear panel in a direction downwardly and inwardly from an outer upper corner of such pocket such that at least one top end of such frame is adjacent to and operatively connectable with a corresponding shoulder strap, and the other end of such frame extends towards and below the opposite corner of such pocket adja-

cent to a lower separable link to the other such pocket. Even further, it provides such a backpack and counterbalancing system, wherein at least one portion of such frame extending below such pocket is operatively connectable with at least one holster fixed to a corresponding hip/waist belt buckle part which forms the separable link to the other such pocket.

[0015] Even further, it provides such a backpack and counterbalancing system, wherein such frame of each such pocket comprises at least one semi-rigid material comprising a shapeable memory, allowing the shape of such frame to be custom shaped to match body contours of the wearer. Even further, it provides such a backpack and counterbalancing system, wherein such frame in such at least one rear panel of each such pocket further comprises a flexible but longitudinally rigid material positioned around a side and top perimeter of each such pocket. Even further, it provides such a backpack and counterbalancing system, wherein such at least one separable link comprises at least a two part clip. Even further, it provides such a backpack and counterbalancing system, wherein such at least one separable link comprises at least one buckle.

[0016] In accordance with another preferred embodiment hereof, this invention provides a backpack and counterbalancing system comprising: carrier means for carrying at least one load to be worn by at least one wearer; shoulder attacher means for attaching such carrier means to shoulders of the at least one wearer; load balancing means for balancing a load within such carrier means; positioner means for positioning such load balancing means in front of the at least one wearer; alignment assister means for assisting alignment of such load balancing means in general vertical alignment; wherein such alignment assister means comprises connector means for connecting such load balancing means to such shoulder attacher means, and adjuster means for adjusting such connector means; and supporter means for supporting such load balancing means.

[0017] Lastly, this invention provides each and every novel feature, element, combination, step and/or method disclosed or suggested herein.

BRIEF DESCRIPTION OF THE DRAWINGS

[0018] FIG. 1 shows a front view of a first preferred embodiment of the invention being worn by a wearer illustrating the position of the pockets.

[0019] FIG. 2 shows a front view of a second preferred embodiment of the invention being worn by a wearer illustrating the position of the pockets.

[0020] FIG. 3 shows a perspective view of a third preferred embodiment of the invention being worn by a wearer backpack illustrating the position of the pockets.

[0021] FIG. 4A shows a preferred embodiment clip attached to a right chest strap before attachment to a left chest strap of the backpack shown in FIG. 3.

[0022] FIG. 4B shows the clip of FIG. 4A with the left chest strap attached to the clip.

[0023] FIG. 5 is a rear view of the pockets of the backpack of FIG. 1.

[0024] FIG. 6 is a front view of a hip belt buckle of the backpack of FIG. 1.

[0025] FIG. 7 is a rear view of the pockets of the backpack of FIG. 2.

[0026] FIG. 8 is a rear view of the pockets of the backpack of FIG. 3.

DETAILED DESCRIPTION OF THE BEST
MODES AND PREFERRED EMBODIMENTS OF
THE INVENTION

[0027] It is noted that in the following description, references to the “left side”, “right side”, “upper”, and “lower” refer to the parts of the system from the point of view of the wearer.

[0028] FIG. 1 shows a front view of a first preferred embodiment of the invention being worn by a wearer illustrating the position of the pockets. The backpack (which may also be called a rucksack, knapsack, packsack, pack, Haversack, or Bergen) worn by the wearer preferably comprises a backpack body, preferably a shoulder harness preferably comprising left shoulder strap 8A and a right shoulder strap 8B, and preferably hip/waist belt 7 (which may preferably rest on the hips of the wearer), as shown. The shoulder harness preferably allows the backpack body to be carried on the back of a wearer, as shown. Hip/waist belt 7 preferably assists in stabilizing the backpack on the body of the wearer and transferring the carried load onto the hips of the wearer.

[0029] With reference to FIG. 1, left side pocket 1A and right side pocket 1B are shown being worn in front of the wearer. Pockets 1A, 1B are preferably operatively connected to shoulder straps 8A, 8B and to hip/waist belt 7 to maintain pockets 1A, 1B in a generally vertical alignment (at least embodying herein positioner means for positioning said load balancing means in front of the at least one wearer). Each pocket 1A, 1B is preferably a substantially rectangular bag or pouch, as shown. Each pocket 1A, 1B is preferably formed from a suitable textile material, preferably canvas. Each pocket 1A, 1B preferably comprises at least one frame 2, which is described in more detail below with reference to FIG. 5.

[0030] Hip/waist belt 7 preferably comprises left side portion 6A and right side portion 6B, as shown. Portions 6A, 6B of hip/waist belt 7 are preferably releasably connected preferably by way of buckle 4, as shown. Preferably, holsters 3 are preferably attached preferably on each side of the buckle 4 of hip/waist belt 7, as shown. The end of frame 2 preferably extends beyond the lower edge of a corresponding pocket 1A, 1B and preferably fits into the corresponding holster 3, as shown. The gap at the bottom of pockets 1A, 1B is preferably a fixed distance preferably determined by the width of buckle 4 and holsters 3. Adjustment of the length of hip/waist belt 7 is preferably achieved by adjusting straps 5 and buckles 6 on hip/waist belt 7.

[0031] The top of pockets 1A, 1B are preferably stabilized by at least one separable link, as shown. The separable link operatively connects the left side pocket to a right side portion of the backpack and the right side pocket to a left side portion of the backpack. In the first embodiment, the separable link is in the form of a linking strap extending from the top portion of each pocket to the opposite shoulder strap. A first linking strap 10A preferably extends between the top of the left side pocket 1A and the right shoulder strap 8B and a second linking strap 10B preferably extends between the top of the right side pocket 1B and the left shoulder strap 8A, as shown.

[0032] The linking straps 10A, 10B are preferably slidably connected to the shoulder straps preferably via sliding connectors 11. The sliding connectors 11 are slidable on secondary straps 9 on the shoulder straps. Secondary straps 9 are preferably fixed to the shoulder straps preferably at or preferably near each end of the shoulder straps. The middle por-

tion of each secondary strap 9 is preferably not attached to the shoulder strap, which allows the sliding connector to slide along the secondary strap 9.

[0033] Linking straps 10A, 10B preferably comprise buckles 12 that are preferably attached preferably to mating buckle parts preferably on pockets 1A, 1B, as shown. In the first embodiment shown, the buckle parts on pockets 1A, 1B are preferably fixed to top inner corners of pockets 1A, 1B preferably via buckle straps 13, as shown. The linking straps 10A, 10B and buckle straps 13, when clipped together via buckles 12, preferably cross the chest of the wearer in an “X” configuration, as shown. The ideal preferred gap between the top of pockets 1A, 1B is preferably achieved preferably by adjusting the height of sliding connectors 11 (at least embodying herein connector means for connecting said load balancing means to said shoulder attacher means, and adjuster means for adjusting said connector means) on secondary shoulder straps 9 and by adjusting the length of straps 10A, 10B (at least embodying herein alignment assister means for assisting alignment of said load balancing means in general vertical alignment) in buckles 12.

[0034] The bottom of each pocket is preferably stabilized by a web and buckle system (see FIG. 5).

[0035] FIG. 2 shows a front view of a second preferred embodiment of the invention being worn by a wearer illustrating the position of the pockets.

[0036] FIG. 2 shows the position of pockets 1A, 1B in front of the wearer according to the second embodiment of the invention. The features and operation are similar to those in the embodiment in FIG. 1 unless otherwise noted. The lower portion of pockets 1A, 1B preferably forms a substantial part of the hip or waist belt of the pack, as shown. In the embodiment shown, the lower portions of pockets 1A, 1B preferably form part of the front of the hip or waist belt. A preferably two-piece buckle 17 is preferably fixed to the bottom inner corners of pockets 1A, 1B preferably via short buckle straps 18, as shown. The position of the bottom of pockets 1A, 1B is preferably a fixed length preferably determined by the width of buckles 17 and the length of buckle straps 18. The top of pockets 1A, 1B are preferably operatively connected to shoulder straps 8A, 8B, as shown. In the second embodiment, pockets 1A, 1B are preferably attached to secondary shoulder straps 9, as shown. The top of pockets 1A, 1B are preferably stabilized preferably by a separable link preferably operatively connected preferably between left pocket 1A and right pocket 1B, as shown. In the second embodiment, the separable link is preferably in the form of, preferably, two-piece buckle 19 preferably attached towards the top inner corner of each pocket 1A, 1B preferably via short buckle webs 20 (also known as webbing), as shown. The gap between the top of pockets 1A, 1B is preferably fixed preferably by the width of buckle 19 and the length of the buckle webs 20. The bottom of pockets 1A, 1B is preferably stabilized by a web and buckle system described in more detail below with reference to FIG. 7.

[0037] FIG. 3 shows a perspective view of a third preferred embodiment of the invention being worn by a wearer backpack illustrating the position of the pockets.

[0038] FIG. 3 shows a backpack according to the third embodiment of the invention. The features and operation are similar to those in the embodiments above unless noted. In the embodiment of FIG. 3, the lower portion of pockets 1A, 1B preferably forms part of hip/waist belt 7 as described in rela-

tion to the second preferred embodiment. Alternately preferably, hip/waist belt 7 may preferably be in the form shown in FIG. 1.

[0039] The third preferred embodiment preferably comprises chest straps 21, as shown. Each chest strap 21 preferably attaches to the corresponding shoulder strap 8 adjacent to the upper chest of the wearer and preferably subsequently passes preferably through clip 22, as shown. Each chest strap 21 then preferably passes preferably under web 23 (shown in FIG. 8) that is preferably attached to the back of the upper portion of pocket 1A, 1B, preferably through an attachment preferably located at the lower portion of the backpack. In the embodiment shown, each chest strap 21 preferably passes through a loop 24 preferably near the base of the pack. Each chest strap 21 preferably subsequently passes upward and through an attachment located at the lower portion of the corresponding shoulder, as shown (see, e.g., buckle 25 at the lower end of the shoulder straps). Chest straps 21 are preferably adjustable in length, as shown. Adjusting the left or the right chest strap 21 preferably simultaneously tightens the left and right shoulder straps 8A, 8B and the left and right chest straps 21.

[0040] Chest straps 21 are preferably free to slide, preferably under the web 23 (see FIG. 8) and preferably through loop 24, allowing the shoulder straps to follow the movements of the body. As shown in FIG. 3, loops 24 are preferably connected to the opposite ends of plastic strip 26 that runs freely in a slot 27 in the bottom of the backpack.

[0041] FIG. 4A shows a preferred embodiment clip attached to a right chest strap before attachment to a left chest strap of the backpack shown in FIG. 3.

[0042] FIG. 4B shows the clip of FIG. 4A with the left chest strap attached to the clip.

[0043] FIG. 4A shows the preferred version of clip 22 of the third embodiment backpack shown in FIG. 3. The clip is preferably formed of a preferably round and preferably rigid material preferably in the shape of an open "9". Webs 21 preferably fold as they pass over the side portions of clip 22, as shown. A plastic holder 28 is preferably bent preferably around the long edge of the clip 22 and preferably secured by rivet 29, as shown. This holds the strap 21 in place on one side of the chest of the wearer when in use. The position of clip 22 may be altered by preferably sliding it along the corresponding strap 21. Strap 21 on the other side of the chest is preferably connected to clip 22 by preferably placing inside open end of clip 22 as shown in FIG. 4B. Alternately preferably, the clip may be replaced preferably with a one part buckle or alternately preferably with a two part buckle.

[0044] FIG. 5 is a rear view of the pockets of the backpack of FIG. 1.

[0045] More particularly, FIG. 5 is an elevation view of pockets 1A, 1B from the back of the first embodiment of the invention. The back of each pocket 1A, 1B preferably contains web sleeve 30 preferably to hold frame 2 in place. Frame 2 is preferably made of a preferably semi-rigid material preferably with a shapeable memory. Frame 2 may be preferably shaped or preferably bent to match the body contours of the wearer. Web sleeve 30 preferably starts at the upper outer corner of pocket 1A, 1B, and preferably passes diagonally preferably down the back and extends beyond the opposite lower inner corner of pocket 1A, 1B, as shown. At top end of sleeve 30 preferably is clip 31, as shown. Clip 31 preferably attaches to strap 9 preferably located on shoulder straps 8A, 8B (at least embodying herein shoulder attacher means for

attaching said carrier means to shoulders of the at least one wearer). On the opposite top corner is buckle 12 that preferably attaches preferably to mating buckle part of buckle 12 on the opposite pocket, or alternately preferably to a mating buckle part on strap 10 as shown and described with reference to FIG. 1.

[0046] To stabilize the bottom of pockets 1A, 1B, preferably an adjustable length connector is preferably operatively connected preferably to left side pocket 1A and a left lower portion of the backpack or to the hip belt, as shown. A corresponding adjustable length connector is preferably operatively connected to the right side pocket 1B and a right lower portion of the backpack or to the hip belt. The adjustable length connector and separable link are preferably on opposite corners of each pocket to the diagonal framings. This is the preferred position for stabilizing pockets 1A, 1B. Buckle 33 is preferably attached preferably via web 34 to the corner diagonally opposite buckle 12 of each pocket. Strap 35 preferably passes through buckle 33 and preferably locates clip 36, as shown. Strap 35 is preferably made of an elasticized material. Clip 36 preferably attaches to a loop on the hip/waist belt or the lower rear portion of the backpack.

[0047] FIG. 6 is a front view of a hip/waist belt buckle of the backpack of FIG. 1. Each holster 3 is preferably attached to each of the hip/waist belt buckle piece 5, as shown. Each holster 3 preferably has an opening preferably at the top of holster 3 for insertion of the free end of each frame 2 (at least embodying herein supporter means for supporting said load balancing means), as shown. In the embodiment shown, holster 3 is preferably formed by a plastic sheet preferably folded around the end bar of buckle part 5 and preferably secured together by suitable means, preferably by a rivet (not shown). Retainer web 32, preferably attached preferably to the front and back of holster 3, preferably helps to further locate the hip/waist belt web 7.

[0048] FIG. 7 is a rear view of the pockets of the backpack of FIG. 2.

[0049] More particularly, FIG. 7 is an elevation view of pockets 1A, 1B from the back according to the second embodiment of the invention. The back of each pocket 1A, 1B preferably contains a sleeve 30 preferably for holding a frame. Sleeve 30 preferably runs from one top corner to the opposite bottom corner of pocket 1A, 1B, as shown. Padded section 37 preferably covers the lower portion of the back of pocket 1A, 1B. At the top of sleeve 30, clip 31 is preferably located that preferably attaches to secondary strap 9 on the corresponding shoulder strap 8. On the opposite top corner is preferably buckle 12 that preferably attaches preferably to a mating buckle part preferably on chest strap 10A, 10B (see FIG. 1). Alternately preferably, buckle 12 may preferably attach directly to each other. At the lower end of each pocket, hip/waist belt buckle parts 17 preferably attach to the inside corners of pockets 1A, 1B preferably via buckle straps 18, as shown. On the outside corners, webs 16 preferably connect to buckles 15 that are preferably attached to the lower rear portion of the backpack preferably via webs 14 (see, e.g., FIG. 3), as shown.

[0050] FIG. 8 is a rear view of the pockets of the backpack of FIG. 3.

[0051] More particularly, FIG. 8 is an elevation view of pockets 1A, 1B from the back according to the third embodiment of the invention. The upper portion of each pocket 1A, 1B preferably has strap 23 preferably extending across the width of pocket 1A, 1B. The ends of the strap are preferably

attached, preferably by stitching, to the pocket. The middle portion of strap **23** is preferably free from attachment to the pocket. Chest strap **21** preferably passes under strap **23** and preferably is free to move under strap **23**. The hip/waist belt buckle parts **17** preferably attach to the inside bottom corner of each pocket preferably via web **18**. Web **16** is preferably located on the outside corner of each pocket, as shown. This preferably connects to buckle **15** that is preferably attached to the corresponding lower rear side portion of the backpack (at least embodying herein carrier means for carrying at least one load to be worn by at least one wearer), preferably via web **14** in the same manner as shown in FIG. 3.

[0052] A frame (not visible in FIG. 8), preferably comprising a preferably flexible but preferably longitudinally rigid material, preferably runs around the side and top perimeter of the pocket preferably to stiffen the pocket and prevent collapse under load.

[0053] According to each of the embodiments described, pockets **1A**, **1B** (at least embodying herein load balancing means for balancing a load within said carrier means) are preferably narrow enough to allow free arm movement (the sides of the pockets do not hinder the natural swing of the arms when walking or running), and the gap between each pocket preferably allows the wearer to see the ground between his/her feet as he or she walks.

[0054] Regarding FIGS. 1-8 and the description, it will be understood that the features described in each embodiment of the invention are not exclusive to each embodiment, and may be preferably interchanged.

[0055] Although applicant has described applicant's preferred embodiments of this invention, it will be understood that the broadest scope of this invention includes modifications such as diverse shapes, sizes, and materials. Such scope is limited only by the below claims as read in connection with the above specification. Further, many other advantages of applicant's invention will be apparent to those skilled in the art from the above descriptions and the below claims.

What is claimed is:

1) A backpack and counterbalancing system comprising:

- a) at least one backpack body, having at least one lower portion, to be worn on a back of a wearer;
- b) at least one shoulder harness having at least one left shoulder strap and at least one right shoulder strap;
- c) at least one left side pocket to be worn in front of the wearer;
- d) wherein said at least one left side pocket comprise at least one upper portion, at least one lower portion, and at least one rear panel;
- e) wherein said at least one upper portion of said at least one left side pocket is operatively connected to said at least one left shoulder strap, and wherein said at least one lower portion of said at least one left side pocket is operatively connected, via at least one adjustable length connector, to at least one lower left side portion of said at least one backpack body to maintain said at least one left side pocket in general vertical alignment;
- f) at least one right side pocket to be worn in front of the wearer;
- g) wherein said at least one right side pocket comprises at least one upper portion, at least one lower portion, and at least one rear panel;
- h) wherein said at least one upper portion of said at least one right side pocket is operatively connected to said right shoulder strap and at least one lower portion of said

at least one right side pocket is operatively connected via at least one adjustable length connector to the lower right side portion of said at least one backpack body to maintain the right side pocket in general vertical alignment;

- i) at least one separable link of fixed length operatively connecting said at least one left side pocket to said at least one right side pocket; and
 - j) wherein said at least one rear panel of said at least one left side pocket and said at least one rear panel of said at least one right side pocket each comprise at least one frame extending from said at least one top portion of said at least one rear panel to said at least one bottom portion of said at least one rear panel of a respective side pocket.
- 2) The backpack and counterbalancing system according to claim 1, wherein the connection of each side pocket to a corresponding shoulder strap is via at least one free sliding connection along the length of at least a lower portion of each said shoulder strap.
- 3) The backpack and counterbalancing system according to claim 2, further comprising
- a) at least one right chest strap; and
 - b) at least one left chest strap;
 - c) wherein said at least one right chest strap is slidably connected to, and along the length of, at least one lower portion of said at least one right shoulder strap; and
 - d) wherein said at least one left chest strap is slidably connected to and along the length of at least one lower portion of said at least one left shoulder strap.
- 4) The backpack and counterbalancing system according to claim 3, further comprising
- a) at least one first separable link operatively connecting at least one upper portion of said at least one left side pocket to said at least one right shoulder strap; and
 - b) at least one second separable link operatively connecting at least one upper portion of said at least one right side pocket to said at least one left shoulder strap.
- 5) The backpack and counterbalancing system according to claim 3, further comprising at least two separable links of fixed length operatively connecting said at least one left side pocket and said at least one right side pocket, a first separable link of said at least two separable links connecting said pockets at an upper portion, and a second separable link of said at least two separable links connecting said pockets at a lower portion.
- 6) The backpack and counterbalancing system according to claim 3, further comprising
- a) at least one left chest strap and at least one right chest strap;
 - b) wherein said at least one left chest strap is operatively connected to a middle portion of said at least one left shoulder strap, which passes through at least one loop attached to at least one lower left side portion of said at least one backpack body, and further connects to a lower portion of said at least one left shoulder strap to form a continuous loop on the left side of said backpack;
 - c) wherein said at least one right chest strap, wherein said at least one right chest strap is operatively connected to a middle portion of said at least one right shoulder strap, which subsequently passes through at least one loop attached to a lower right side portion of said at least one backpack body, and further connects to a lower portion of said at least one right shoulder strap to form a continuous loop on the right side of the backpack; and

- d) wherein said shoulder straps are freely moveable through said continuous loops to enable shoulder movement of the wearer.
- 7) The backpack and counterbalancing system according to claim 6, wherein said chest straps are positioned adjacent to the upper chest of the wearer such that each strap runs diagonally downward from said middle portions of said shoulder straps towards the center of the chest of the wearer, and further down towards the corresponding hip of the wearer; and wherein each chest strap may be connected to the opposite chest strap via at least one separable link; such that the two chest straps when connected form an "X" configuration across the chest of the wearer.
- 8) The backpack and counterbalancing system according to claim 7, wherein said at least one separable link comprises at least a one-part clip.
- 9) The backpack and counterbalancing system according to claim 8, wherein said at least one separable link comprises an elongated loop with at least one end open, wherein one side of said loop is slidably connected to at least one chest strap, and wherein the other chest strap may be inserted into the open end of said elongated loop to rest against the other side of said elongated loop and wherein the aforementioned other chest strap is free to slide around the side of the loop when the wearer twists shoulders relative to hips.
- 10) The backpack and the counterbalancing system according to claim 9, wherein
 - a) said chest straps are length adjustable; and
 - b) adjusting said at least one left chest strap simultaneously tightens said at least one left shoulder strap and said at least one left chest strap, and adjusting said at least one right chest strap simultaneously tightens said at least one right shoulder strap and said at least one right chest strap.
- 11) The backpack according to claim 10, further comprising at least one hip/waist belt, and wherein lower portions of said pockets form a substantial part of said hip/waist belt.
- 12) The backpack and counterbalancing system according to claim 10, further comprising at least one hip/waist belt, wherein lower side portions of said at least one backpack body comprise said at least one hip/waist belt.
- 13) The backpack and counterbalancing system according to claim 12, wherein said at least one frame of each said pocket is positioned diagonally across the rear panel in a direction downwardly and inwardly from the outer upper corner of the rear panel such that a top end of said frame is adjacent to and operatively connectable with a corresponding shoulder strap and the other end of said frame is adjacent to a lower separable link to the other said pocket.

- 14) The backpack and counterbalancing system according to claim 12, wherein said frame in each pocket is positioned diagonally across said at least one rear panel in a direction downwardly and inwardly from an outer upper corner of said pocket such that at least one top end of said frame is adjacent to and operatively connectable with a corresponding shoulder strap, and the other end of said frame extends towards and below the opposite corner of said pocket adjacent to a lower separable link to the other said pocket.
- 15) The backpack and counterbalancing system according to claim 14, wherein at least one portion of said frame extending below said pocket is operatively connectable with at least one holster fixed to a corresponding hip/waist belt buckle part which forms the separable link to the other said pocket.
- 16) The backpack and counterbalancing system according to claim 15, wherein said frame of each said pocket comprises at least one semi-rigid material comprising a shapeable memory, allowing the shape of said frame to be custom shaped to match body contours of the wearer.
- 17) The backpack and counterbalancing system according to claim 17, wherein said frame in said at least one rear panel of each said pocket further comprises a flexible but longitudinally rigid material positioned around a side and top perimeter of each said pocket.
- 18) The backpack and counterbalancing system according to claim 7, wherein said at least one separable link comprises at least a two part clip.
- 19) The backpack and counterbalancing system according to claim 7, wherein said at least one separable link comprises at least one buckle.
- 20) A backpack and counterbalancing system comprising:
 - a) carrier means for carrying at least one load to be worn by at least one wearer;
 - b) shoulder attacher means for attaching said carrier means to shoulders of the at least one wearer;
 - c) load balancing means for balancing a load within said carrier means;
 - d) positioner means for positioning said load balancing means in front of the at least one wearer;
 - e) alignment assister means for assisting alignment of said load balancing means in general vertical alignment;
 - f) wherein said alignment assister means comprises
 - i) connector means for connecting said load balancing means to said shoulder attacher means, and
 - ii) adjuster means for adjusting said connector means; and
 - g) supporter means for supporting said load balancing means.

* * * * *