



US007448659B1

(12) **United States Patent**
Auseklis

(10) **Patent No.:** **US 7,448,659 B1**
(45) **Date of Patent:** **Nov. 11, 2008**

- (54) **PET DEBRIS SCOOPER SYSTEMS**
- (76) Inventor: **Alexander E. Auseklis**, 2269 Chestnut St., #194, San Francisco, CA (US) 94123
- (*) Notice: Subject to any disclaimer, the term of this patent is extended or adjusted under 35 U.S.C. 154(b) by 364 days.
- (21) Appl. No.: **11/343,449**
- (22) Filed: **Jan. 30, 2006**

Related U.S. Application Data

- (60) Provisional application No. 60/702,784, filed on Jul. 26, 2005.
- (51) **Int. Cl.**
A01K 29/00 (2006.01)
E01H 1/12 (2006.01)
- (52) **U.S. Cl.** **294/1.4**
- (58) **Field of Classification Search** 294/1.3, 294/1.4, 1.5; 15/104.8, 257.1, 257.6; 119/161
See application file for complete search history.

4,186,955 A	2/1980	Campbell	
4,194,777 A	3/1980	Carns	
4,201,409 A	5/1980	O'Hara	
4,205,869 A	6/1980	Mathis	
4,215,886 A	8/1980	Naderi et al.	
4,221,415 A	9/1980	Ganz	
4,225,174 A	9/1980	Hennessy et al.	
4,230,354 A	10/1980	Claras	
4,243,259 A	1/1981	Wright	
4,247,139 A *	1/1981	Grieb	294/1.4
4,253,691 A	3/1981	Liu	
4,257,635 A	3/1981	Mainprice	
4,257,636 A	3/1981	Mainprice	
4,316,627 A	2/1982	Solya	
4,323,272 A	4/1982	Fortier	
4,335,678 A	6/1982	Garza et al.	
4,368,907 A	1/1983	Ross	

(Continued)

- (56) **References Cited**
U.S. PATENT DOCUMENTS

3,738,697 A	6/1973	Kahan	
3,971,503 A	7/1976	Allan et al.	
3,984,139 A	10/1976	Battaglia	
3,986,744 A	10/1976	Krogstad et al.	
4,010,970 A	3/1977	Campbell	
4,012,067 A	3/1977	Travis	
4,014,584 A	3/1977	Bau et al.	
4,017,015 A	4/1977	Jefferson	
4,021,994 A	5/1977	Mainprice	
4,056,278 A	11/1977	Bau et al.	
4,097,082 A	6/1978	Orofino	
4,103,952 A	8/1978	Thompson	
4,103,953 A	8/1978	Lachance	
4,119,337 A *	10/1978	Sherhandt	294/1.4
4,121,866 A	10/1978	Schall et al.	
4,146,259 A	3/1979	Schultz	
4,179,145 A	12/1979	Shinsako	

Primary Examiner—Dean J Kramer
(74) *Attorney, Agent, or Firm*—Stoneman Volk Patent Group; Martin L. Stoneman; Michael D. Volk, Jr.

(57) **ABSTRACT**

A system for picking up solid objects, such as pet debris and pet waste, and automatically sealing such pet waste within a disposable liner. The liner is installed on a hand-held scooper device by an automatic applicator. The liners are design specifically for the system and comprise a self-sealing feature adapted to assist in encapsulating the waste. The applicator also functions as a storage holder for the hand-held scoop. A kit comprising the hand-held scoop device, the storage automatic applicator, and disposable liners is also disclosed.

20 Claims, 8 Drawing Sheets

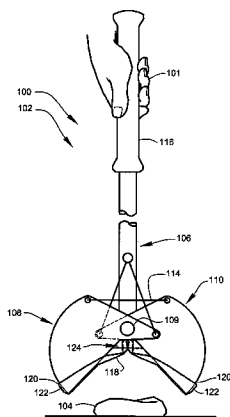

U.S. PATENT DOCUMENTS

4,383,710 A	5/1983	Fehr	5,713,616 A	2/1998	Knudson
4,444,152 A	4/1984	Berardo	5,718,469 A	2/1998	Ockerman
4,447,082 A	5/1984	Lindholm	5,725,268 A	3/1998	Besasie et al.
4,458,932 A	7/1984	Resch	5,738,444 A	4/1998	Lantz et al.
4,477,111 A	10/1984	Crooks	5,741,036 A	4/1998	Ring
4,500,125 A	2/1985	Olson	5,785,369 A	7/1998	Ridley, Sr. et al.
D279,512 S	7/1985	Schaffer	5,799,993 A	9/1998	Lafferty
D283,262 S	4/1986	Kline	5,803,293 A	9/1998	Lovekin
4,645,252 A	2/1987	Riley	5,829,671 A	11/1998	Hawk
4,717,186 A	1/1988	Yoshioka	5,860,742 A	1/1999	Faircloth, Jr.
4,718,707 A	1/1988	Greenhut	5,865,486 A	2/1999	Bussani
4,741,565 A	5/1988	Bagg	5,868,447 A	2/1999	Clark et al.
4,765,666 A	8/1988	Parks	5,899,510 A	5/1999	Hayes et al.
4,776,621 A	10/1988	Streit	5,931,117 A	8/1999	Lantz et al.
D298,369 S	11/1988	Shun et al.	5,971,452 A	10/1999	Marymor et al.
4,854,624 A	8/1989	Baymiller	D418,261 S	12/1999	Betts et al.
4,865,371 A	9/1989	Egberg	6,003,913 A	12/1999	Flumiani
4,875,729 A	10/1989	Peck	6,012,748 A	1/2000	Franks
4,896,912 A	1/1990	Parnell	6,030,011 A	2/2000	Layton
4,900,077 A	2/1990	Beck	6,062,168 A	5/2000	Host et al.
4,909,553 A	3/1990	Hantover	6,082,574 A	7/2000	Johnson
4,958,871 A	9/1990	Hemans	6,086,123 A	7/2000	Sowenski et al.
4,962,956 A	10/1990	Scriptor	6,098,569 A	8/2000	Kent et al.
5,033,781 A	7/1991	Flood	6,102,457 A	8/2000	Smith
5,039,148 A	8/1991	Brautovich	6,113,166 A	9/2000	Wynn
5,054,828 A	10/1991	Hantover	6,126,215 A	10/2000	Jahns
5,167,377 A	12/1992	Chalmers	6,129,050 A	10/2000	Carbajal
D334,255 S	3/1993	Nelson	6,135,520 A	10/2000	Miller et al.
D334,638 S	4/1993	Blackman	6,142,543 A	11/2000	Friberg
5,205,107 A	4/1993	Herink	6,164,710 A	12/2000	Shibuya
5,236,237 A	8/1993	Shultz	6,170,692 B1	1/2001	Johnston
5,269,575 A	12/1993	Parvaresh	6,196,601 B1	3/2001	Juntunen, Jr.
5,280,978 A	1/1994	Bohn	6,199,737 B1	3/2001	Ringelstetter
5,282,660 A	2/1994	Halling	6,202,595 B1	3/2001	Atcravi
5,295,721 A	3/1994	Wu	6,216,634 B1	4/2001	Kent et al.
5,318,330 A	6/1994	Dombrowski	6,227,473 B1	5/2001	Arnold
5,320,393 A	6/1994	Cortinas	6,237,972 B1	5/2001	Jung
5,335,952 A	8/1994	Clapper	6,257,473 B1	7/2001	Ringelstetter
5,350,208 A	9/1994	Heinrichson	D446,696 S	8/2001	Allison
5,355,836 A	10/1994	Vallery	6,276,300 B1	8/2001	Lewis, II et al.
5,360,247 A	11/1994	Vachter	6,305,322 B1 *	10/2001	Patel 119/161
5,370,431 A	12/1994	Henninger et al.	6,315,448 B1	11/2001	Thrall
5,382,063 A	1/1995	Wesener et al.	6,332,429 B1	12/2001	Gramlich
5,386,802 A	2/1995	Hang-Fu	6,354,243 B1	3/2002	Lewis, II et al.
5,394,833 A	3/1995	Glass	6,378,577 B1	4/2002	Piner et al.
5,400,572 A	3/1995	Peck et al.	6,394,514 B1	5/2002	Kidd
5,409,279 A	4/1995	Magee	6,439,627 B1	8/2002	Devane
5,410,987 A	5/1995	Simmons	6,478,351 B1	11/2002	Nelson
5,476,296 A	12/1995	Gross	6,478,465 B1	11/2002	Thrall
5,482,337 A	1/1996	Rose	6,485,073 B2	11/2002	Harrison
5,503,442 A	4/1996	Lee	6,554,334 B2	4/2003	Rincon Uribe
5,540,469 A	7/1996	Albert	6,554,335 B1	4/2003	Kelley et al.
5,564,762 A	10/1996	Ring	6,588,375 B2	7/2003	Benedetti
5,564,763 A	10/1996	Mercurio	6,590,146 B1	7/2003	Mrsny
5,579,812 A	12/1996	Bigwood	6,641,188 B2	11/2003	Arceo
5,580,111 A	12/1996	Bohn	D483,159 S	12/2003	Boyd
5,584,519 A	12/1996	Myles et al.	D485,025 S	1/2004	Edwards et al.
5,586,521 A	12/1996	Kelley	6,702,349 B2	3/2004	Clements
5,601,321 A	2/1997	Simon	6,832,796 B1	12/2004	Minassians
5,620,220 A	4/1997	Khoshnood	6,837,187 B2	1/2005	Berardo
5,624,144 A	4/1997	Roche	6,932,399 B2	8/2005	Fonfrias
5,628,537 A	5/1997	Kiemer	2004/0004361 A1	1/2004	Foster et al.
5,634,678 A	6/1997	Bailey	2004/0100108 A1 *	5/2004	Cappellano et al. 294/1.3
5,661,873 A	9/1997	Karet	2004/0124646 A1	7/2004	Peko
5,667,264 A	9/1997	Tanahara	2004/0145196 A1	7/2004	Katz
5,671,959 A	9/1997	Tsou	2005/0111763 A1	5/2005	Jung
5,713,302 A	2/1998	Walter	2005/0194799 A1	9/2005	Karimi et al.

* cited by examiner

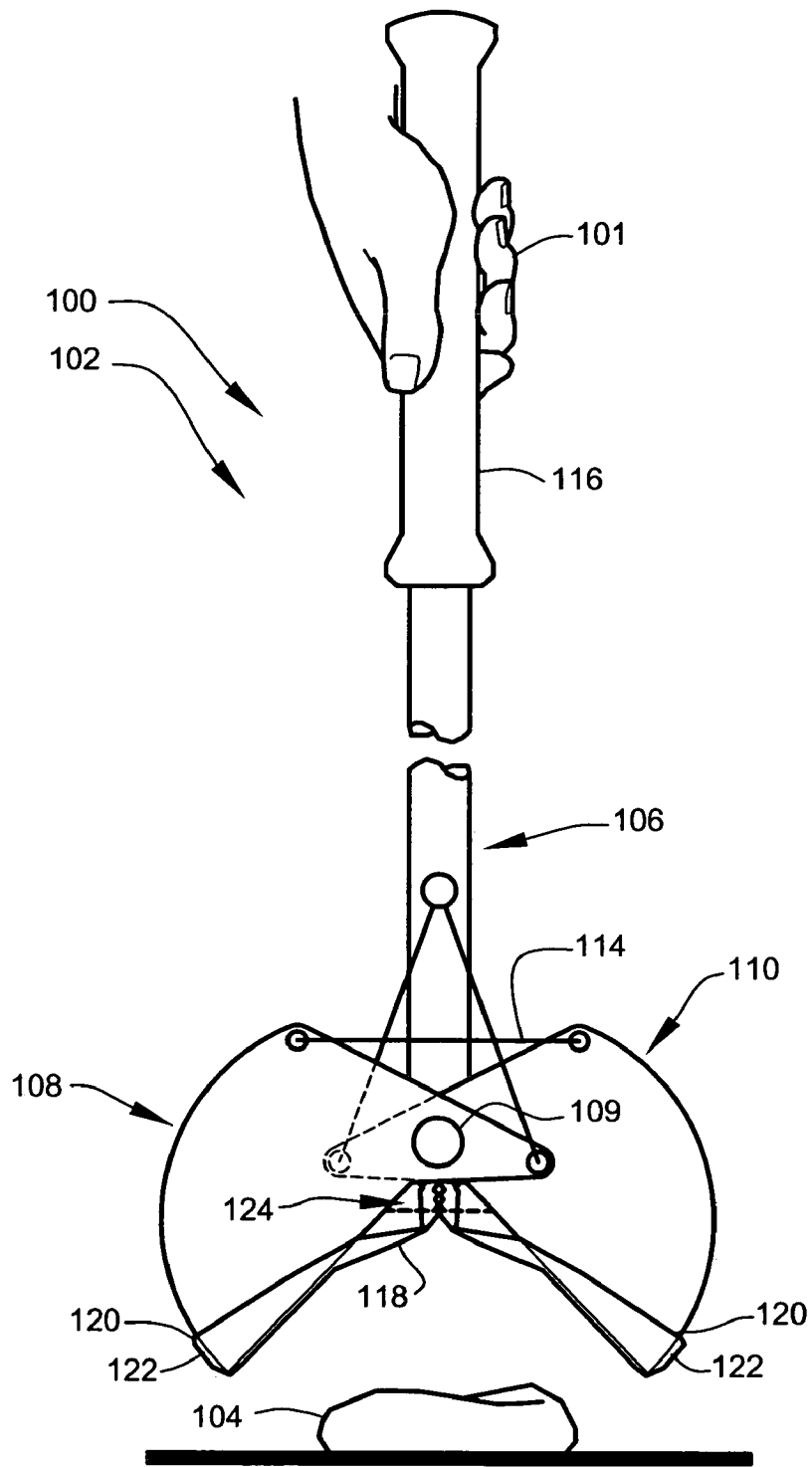

FIG. 1

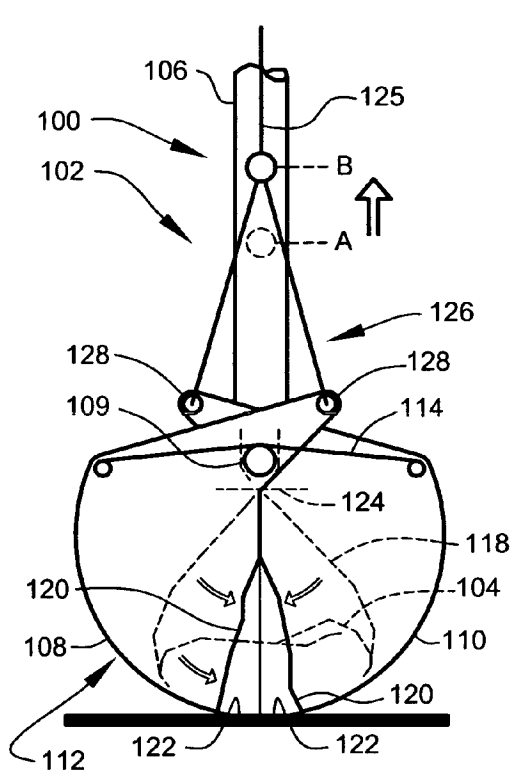

FIG. 2

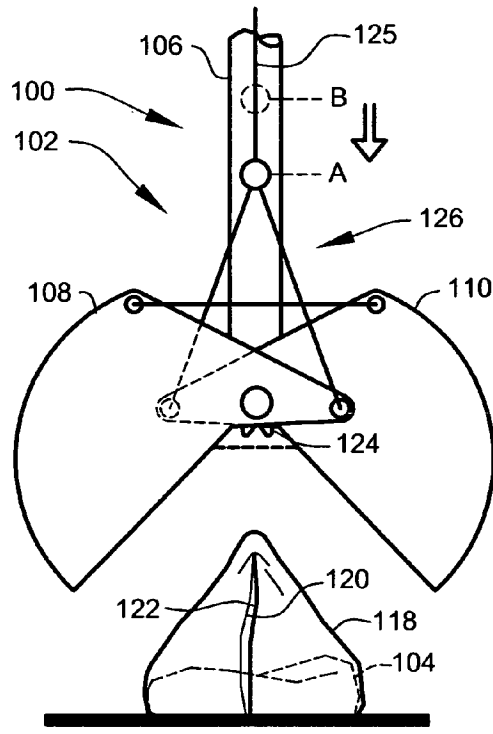

FIG. 3

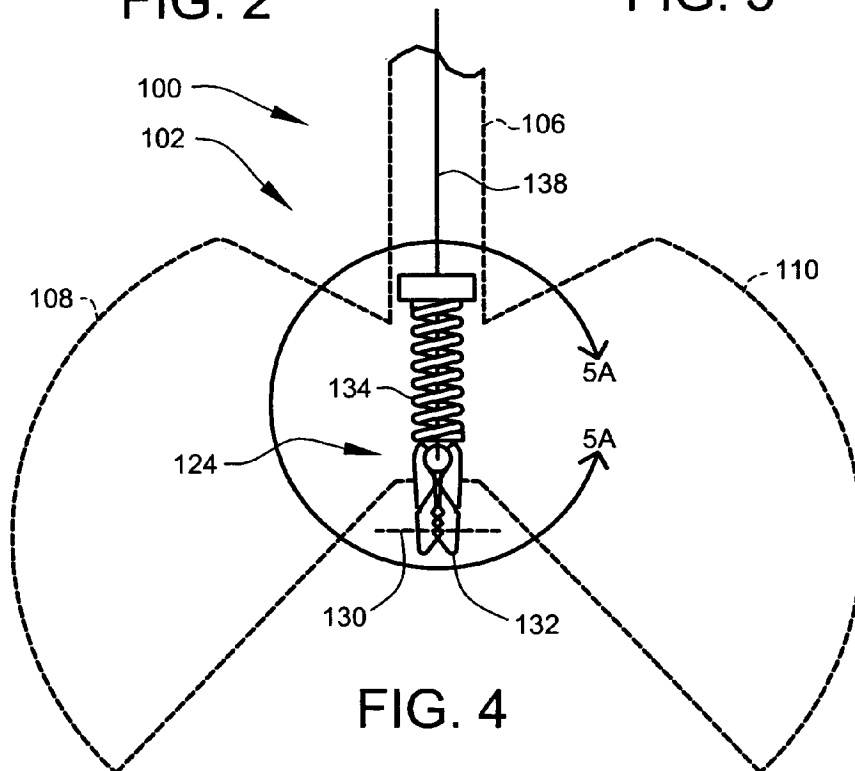

FIG. 4

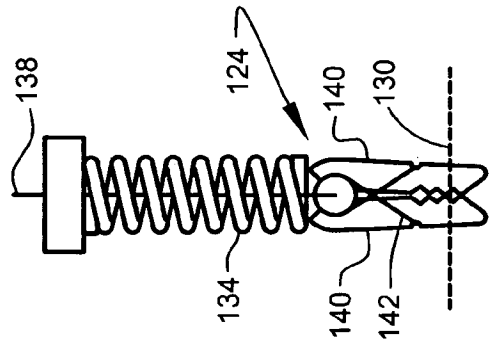

FIG. 5A

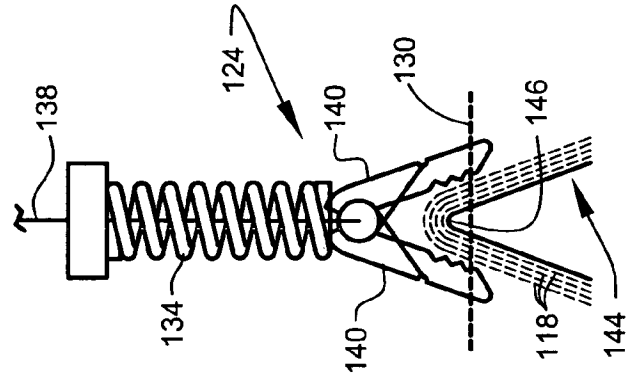

FIG. 5B

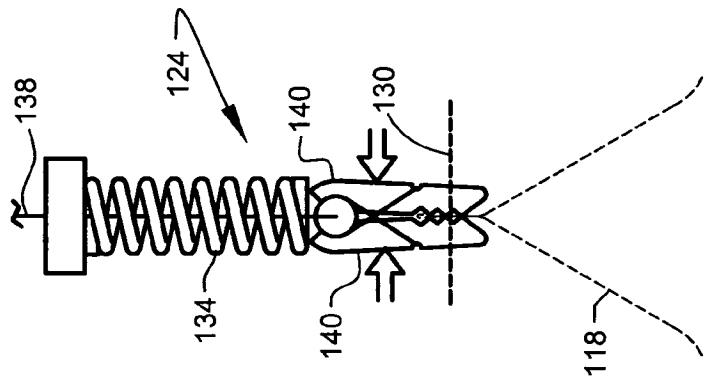

FIG. 5C

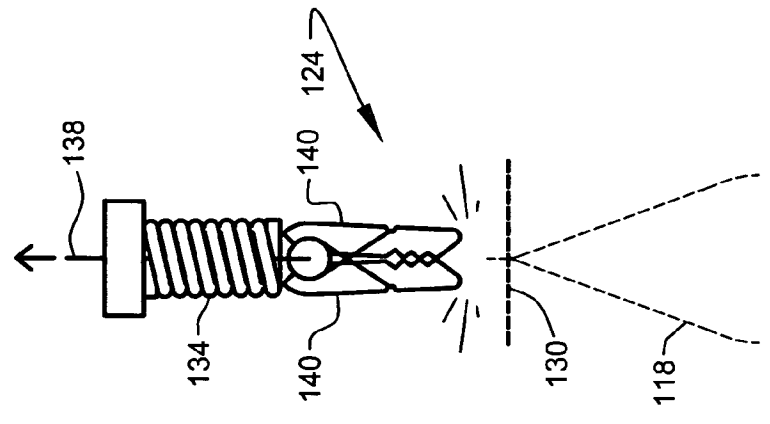

FIG. 5D

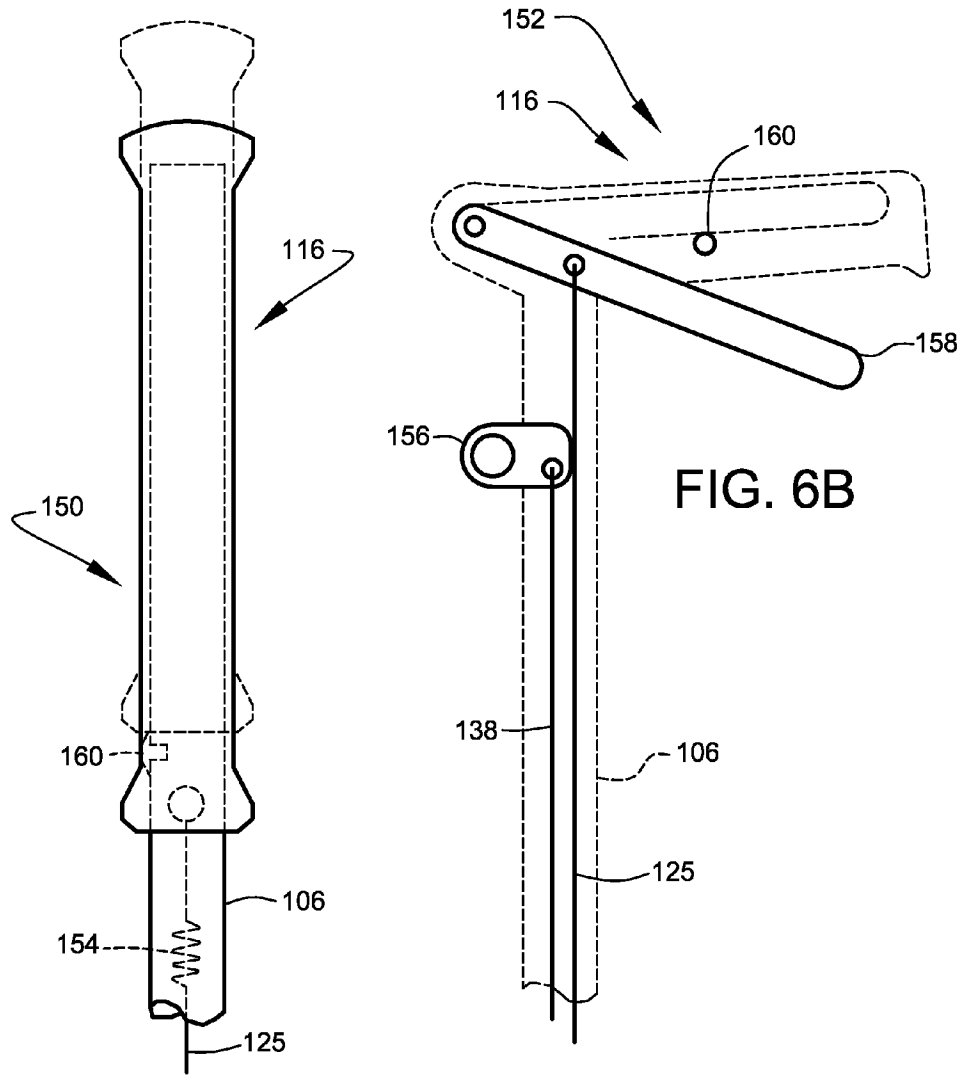

FIG. 6A

FIG. 6B

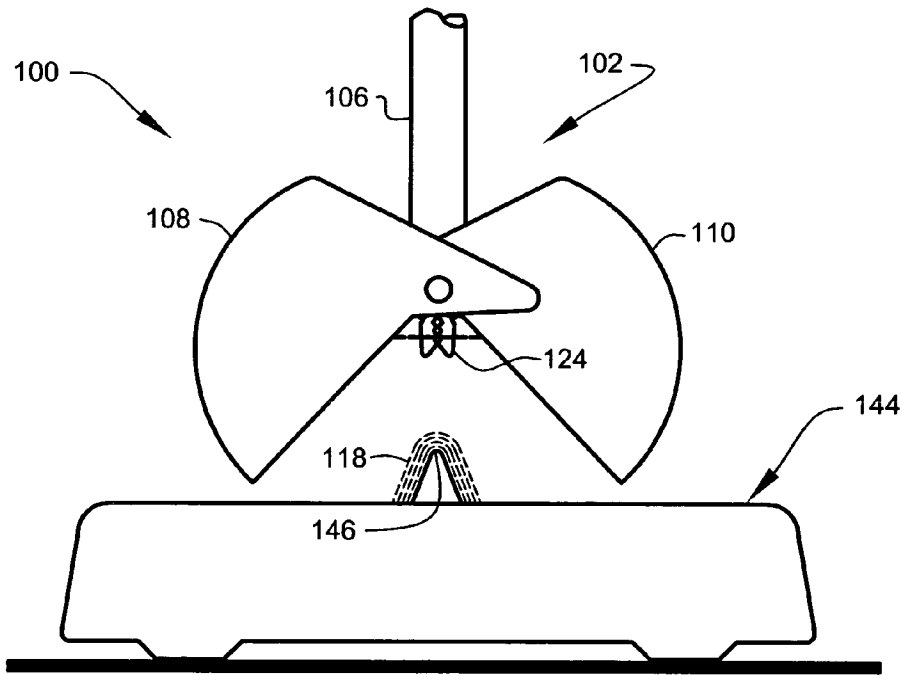

FIG. 7A

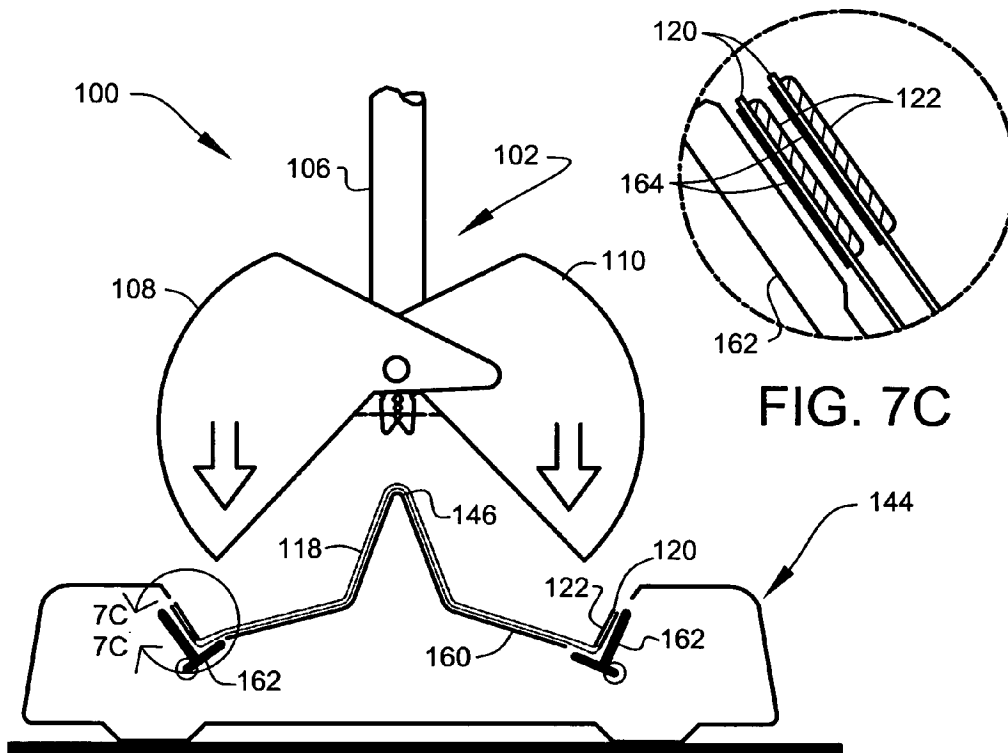

FIG. 7C

FIG. 7B

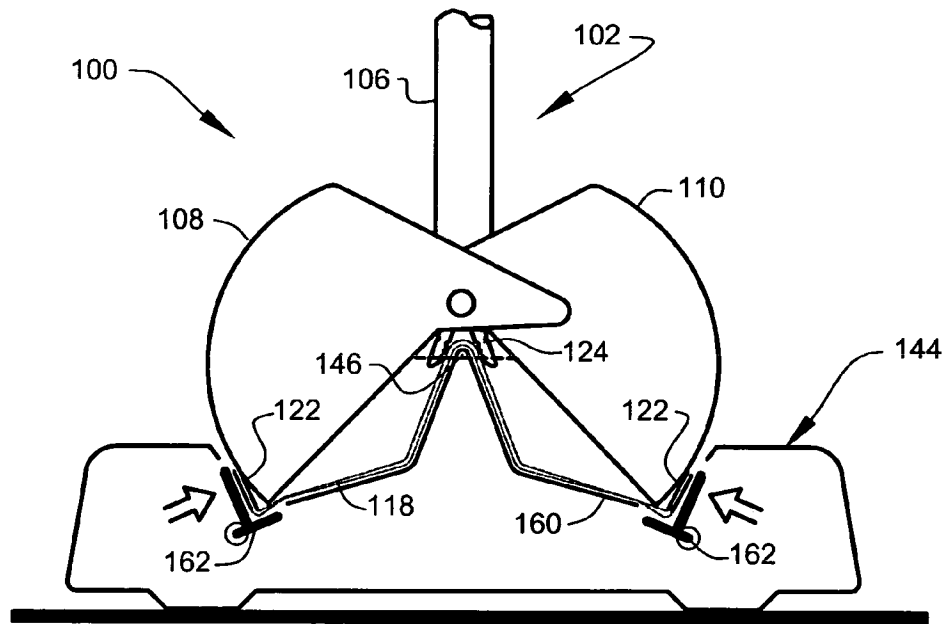

FIG. 7D

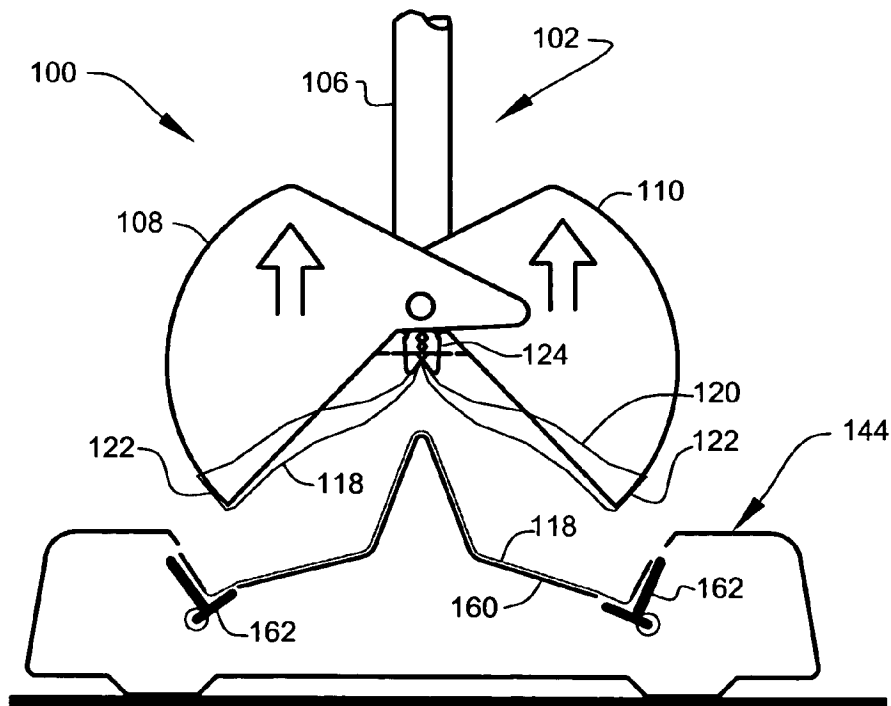

FIG. 7E

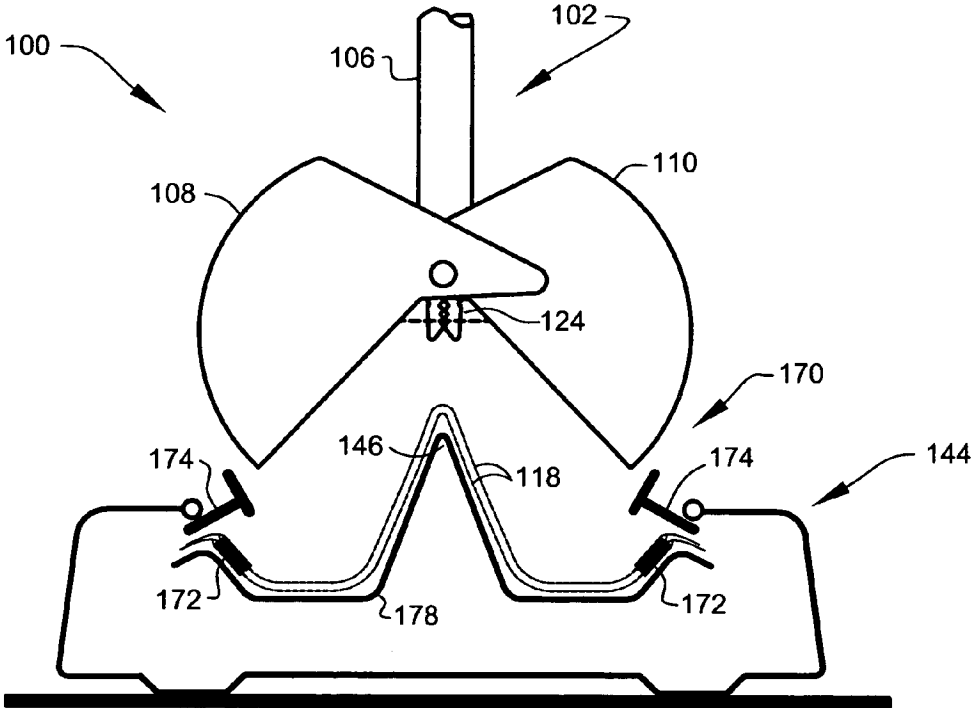

FIG. 8A

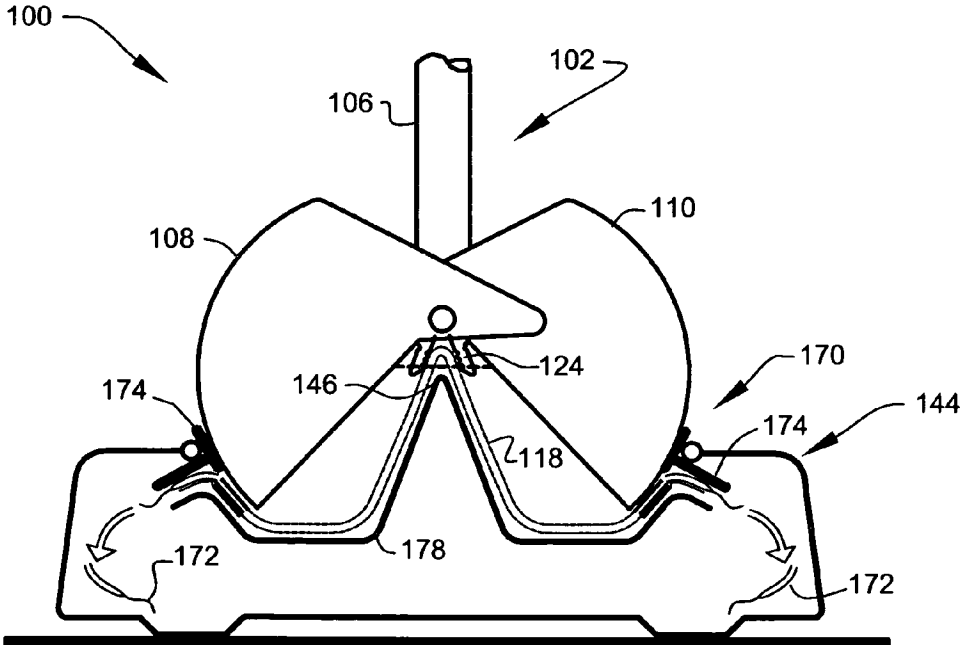
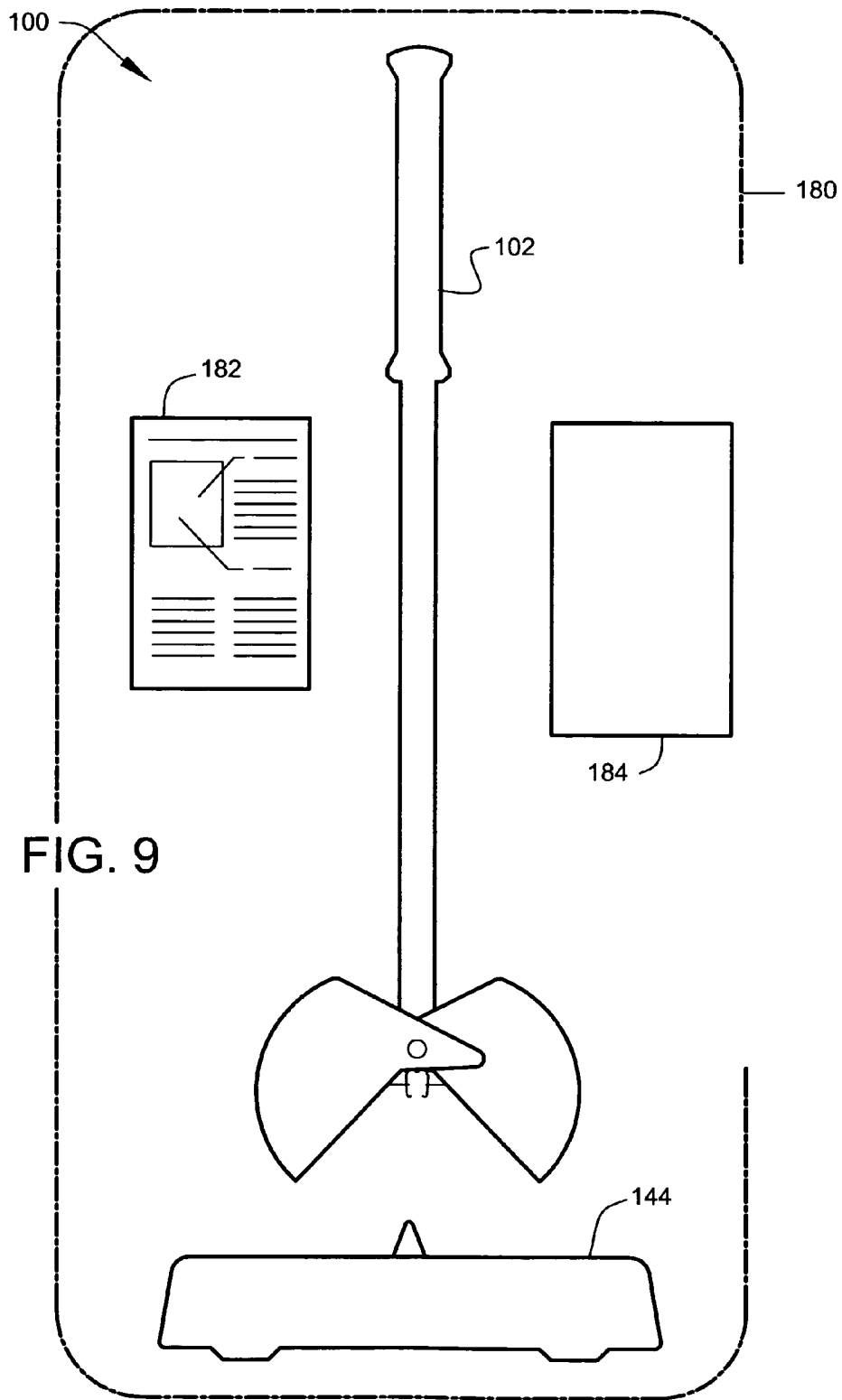

FIG. 8B



1

PET DEBRIS SCOOPER SYSTEMS**CROSS-REFERENCE TO RELATED APPLICATION**

The present application is related to and claims priority from prior provisional application Ser. No. 60/702,784, filed Jul. 26, 2005, entitled "A DEVICE FOR PICKING UP, AND SEALING WITHIN A BAG, SOLID OBJECTS, SUCH AS DEBRIS OR WASTE, HEREAFTER CALLED A "SCOOPER", the contents of which are incorporated herein by this reference and are not admitted to be prior art with respect to the present invention by the mention in this cross-reference section.

BACKGROUND

This invention relates to providing a system for improved pet waste collection. More particularly, this invention relates to providing a system for the convenient application of a disposable liner to a pet-debris scooper adapted to collect and seal the pet waste and debris within such liner.

Pet waste left in public areas such as streets and sidewalks creates numerous sanitary problems, particularly in metropolitan areas having high population densities. It has been estimated that there are currently 60 million dogs in the United States alone, many of which residing in such large urban areas. Many municipalities have enacted local ordinances requiring that the pet owner clean up after their pets. Such tasks are unpleasant and often difficult to perform while managing the pet.

Because there are no easy to use and effective products currently available, most dog owners resort to the "bag-in-hand" method. Using a plastic grocery bag, the pet owner hand scoops the pet waste, closes the bag, and disposes of the waste in a trash receptacle. Some longtime dog owners have resigned to this primitive method, but new owners are understandably repulsed by the above-described technique. It is therefore clear that a need exists for devices that provide clean and efficient collection and disposal of pet waste, in a convenient and sanitary fashion.

OBJECTS AND FEATURES OF THE INVENTION

It is the primary object and feature of the present invention to overcome the above-described problems. It is another primary object and feature of the present invention to provide a system for the convenient application of a disposable liner to a portable pet-debris scooper. It is a further object and feature of the present invention to provide such a system that comprises an improved pet-debris scooper apparatus.

It is another object and feature of the present invention to provide a system wherein the applicator of the disposable liner additionally functions as a convenient holder for the pet-debris scooper. It is a further object and feature of the present invention to provide such a system in the form of the consumer kit.

A further primary object and feature of the present invention is to provide such a system that is efficient, inexpensive, and handy. Other objects and features of this invention will become apparent with reference to the following descriptions.

SUMMARY OF THE INVENTION

In accordance with a preferred embodiment hereof, this invention provides a method related to the collection of at

2

least one pet waste item using at least one hand-holdable grasper comprising the steps of: providing at least one disposable liner adapted to resist the passage of the pet waste; providing at least one applicator adapted to apply such at least one disposable liner to such at least one hand-holdable grasper; loading at least one first at least one disposable liner onto such at least one applicator; loading such at least one hand-holdable grasper onto such at least one applicator, wherein such at least one first at least one disposable liner becomes attached to such at least one hand-holdable grasper; and removing from such at least one applicator, such at least one hand-holdable grasper comprising such at least one first at least one disposable liner.

Moreover, it provides such a waste collection system further comprising the step of grasping the at least one pet waste item with such at least one hand-holdable grasper comprising such at least one first at least one disposable liner, wherein such at least one first at least one disposable liner substantially encapsulates the at least one pet waste item. Additionally, it provides such a waste collection system further comprising the step of releasing such at least one first at least one disposable liner from such at least one hand-holdable grasper, wherein such at least one first at least one disposable liner substantially encapsulates the at least one pet waste item. Also, it provides such a waste collection system further comprising the step of loading such at least one hand-holdable grasper onto such at least one applicator for storage, wherein at least one second at least one disposable liner becomes attached to such at least one hand-holdable grasper.

In accordance with another preferred embodiment hereof, this invention provides a system related to the collection and encapsulation of pet waste within at least one liner comprising at least one membrane substantially impermeable to the pet waste, such system comprising: at least one grasper adapted to grasp the pet waste; at least one holding component adapted to hold such at least one grasper; wherein such at least one holding component comprises at least one holder adapted to hold the at least one liner; wherein such at least one holding component further comprises at least one applicator adapted to apply the at least one liner to such at least one grasper; and wherein such at least one grasper comprises at least one hand grip to assist hand gripping of such at least one grasper during such applying of the at least one liner to such at least one grasper and during such grasping of the pet waste by such at least one grasper.

In addition, it provides such a system further comprising: such at least one liner; wherein such at least one liner comprises at least one membrane substantially impermeable to the pet waste; and wherein such at least one membrane is substantially flexible. And, it provides such a system wherein: such at least one grasper comprises at least one container adapted to contain the pet waste; such at least one container comprises at least one first containment wall and at least one second containment wall; such at least one first containment wall is movably positionable relative to such at least one second containment wall; such at least one first containment wall and at least one second containment wall are together adapted to comprises at least one substantially enclosable interior portion; and such at least one substantially enclosable interior portion is adapted to receive at least one liner portion of such at least one liner.

Further, it provides such a system wherein: such at least one liner comprises at least one releasable adhesive adapted to releasably adhere the at least one liner to such at least one first containment wall and such at least one second containment wall; and such at least one applicator is adapted to assist in adhering such at least one releasable adhesive of such at

3

least one liner to such at least one first containment wall and such at least one second containment wall. Even further, it provides such a system wherein: such at least one grasper further comprises at least one liner retainer adapted to retain such at least one liner portion of such at least one liner; and such at least one liner retainer is positioned substantially within such at least one substantially enclosable interior portion.

Moreover, it provides such a waste collection system, wherein: such at least one liner retainer comprises at least one puller adapted to pull such at least one liner into such at least one substantially enclosable interior portion; and such pulling of such at least one liner into such at least one substantially enclosable interior portion detaches such at least one liner from such at least one first containment wall and such at least one second containment wall. Additionally, it provides such a system, wherein: such at least one liner comprises at least one sealer structured and arranged to seal such at least one liner substantially around the pet waste; wherein such at least one sealer is adapted to be assisted in such sealing of such at least one liner substantially around the pet waste by such pulling of such at least one liner into such at least one substantially enclosable interior portion.

Also, it provides such a system, wherein such at least one sealer comprises at least one contact adhesive. In addition, it provides such a system, wherein such at least one sealer comprises at least one self-sealing material comprising at least one flexible film coated with at least one pressure sensitive adhesive adapted to self-seal by at least one application of mechanical pressure. And, it provides such a system further comprising: at least one releaser adapted to release such at least one liner from such at least one liner retainer; and such at least one releaser is controlled by such pulling of such at least one liner by such at least one puller.

Further, it provides such a system wherein: such at least one hand grip comprises at least one elongated handle adapted to support such at least one first containment wall and such at least one second containment wall; such at least one first containment wall and such at least one second containment wall each comprise at least one generally scoop-shaped member; at least one of such at least one generally scoop-shaped members comprises at least one pivoting coupler adapted to movably join at least one of such at least one generally scoop-shaped members to such at least one elongated handle. Even further, it provides such a system wherein such at least one substantially enclosable interior portion of such at least one container is formable by the positioning of at least one of such at least one generally scoop-shaped members adjacent at least one other such at least one generally scoop-shaped members. Even further, it provides such a system wherein: such at least one liner further comprises at least one removable cover adapted to removably cover such at least one releasable adhesive during storage; and such at least one applicator is adapted to remove such at least one removable cover prior to adherence of such at least one liner to such at least one first containment wall and such at least one second containment wall.

Even further, it provides such a system wherein: such at least one liner further comprises at least one periphery comprising at least one first peripheral side and at least one second peripheral side; such at least one first peripheral side comprises such at least one releasable adhesive; such at least one second peripheral side comprises at least one adhesive resistor adapted to resist adherence of such at least one releasable adhesive; and at least one such at least one liner is stackable over at least one other such at least one liner without adherence between such at least one first peripheral side and such at

4

least one second peripheral side. Even further, it provides such a system wherein such at least one applicator further comprises at least one positional director adapted to positionally direct such at least one liner to at least one retainable position adjacent such at least one liner retainer.

In accordance with another preferred embodiment hereof, this invention provides a kit system related to the collection and encapsulation of pet waste within at least one liner comprising at least one membrane substantially impermeable to the pet waste, such system comprising: at least one grasper adapted to grasp the pet waste wherein such at least one grasper comprises at least one hand grip to assisting hand gripping of such at least one grasper during such grasping of the pet waste by such at least one grasper; at least one holding component adapted to hold such at least one grasper wherein such at least one holding component comprises at least one holder adapted to hold the at least one liner, and wherein such at least one holding component further comprises at least one applicator adapted to apply the at least one liner to such at least one grasper; and at least one set of user instructions for use. Moreover, it provides such a kit system further comprising such at least one liner. Also, it provides such a kit system further comprising at least one packing container adapted to contain such at least one grasper, such at least one holding component, and such at least one set of user instructions for use.

BRIEF DESCRIPTION OF THE DRAWINGS

FIG. 1 shows a side view diagrammatically illustrating a pet-debris scooper of a pet-debris scooper system, according to a preferred embodiment of the present invention;

FIG. 2 shows a partial side view of the pet-debris scooper according to the preferred embodiment of FIG. 1 and further illustrates preferred methods of use;

FIG. 3 shows a partial side view of the pet-debris scooper and continued illustration of the preferred methods of use;

FIG. 4 shows a partial side view diagrammatically illustrating a liner-clamping assembly according to the preferred embodiment of FIG. 1;

FIG. 5A shows the detail view 5A-5A of FIG. 4 generally illustrating the configuration of the liner-clamping assembly of FIG. 4;

FIG. 5B shows the detail view of FIG. 5A with the liner-clamping assembly engaging a disposable liner of the pet-debris scooper system;

FIG. 5C shows the detail view of FIG. 5A with the liner-clamping assembly gripping the disposable liner of FIG. 5B;

FIG. 5D shows the detail view of FIG. 5A with the disposable liner passing through a release barrier adapted to release the disposable liner from the liner-clamping assembly;

FIG. 6A shows a partial side view of a handgrip assembly of the pet-debris scooper of FIG. 1;

FIG. 6B shows a partial side view of an alternate handgrip assembly of the pet-debris scooper of FIG. 1;

FIG. 7A shows side view depicting a disposable-liner dispenser according to a preferred embodiment of the present invention;

FIG. 7B shows a diagrammatic sectional view depicting the internal functional components of the disposable-liner dispenser of FIG. 7A;

FIG. 7C shows the detail view 7C-7C of FIG. 7B illustrating an adhesive strip arrangement on a peripheral edge of the disposable liner;

FIG. 7D shows a diagrammatic sectional view depicting the application of a disposable-liner to the pet-debris scooper of FIG. 1;

5

FIG. 7E shows a diagrammatic sectional view depicting the pet-debris scooper after application of the disposable-liner;

FIG. 8A shows a diagrammatic sectional view depicting the disposable-liner dispenser of FIG. 7A comprising an alternate internal component assembly according to a preferred embodiment of the present invention;

FIG. 8B shows a diagrammatic sectional view depicting the application of a disposable-liner to the pet-debris scooper using the alternate internal component assembly of 8A; and

FIG. 9 shows a preferred kit system according to a preferred embodiment of the present invention.

DETAILED DESCRIPTION OF THE BEST MODES AND PREFERRED EMBODIMENTS OF THE INVENTION

FIG. 1 shows a side view diagrammatically illustrating pet-debris scooper 102 of pet-debris scooper system 100, held in a position of use by the hand of user 101, according to a preferred embodiment of the present invention. Unless noted otherwise, in the present discussion, the terms “up” (upwardly) and “down” (downwardly) reference the position of the embodiment as depicted in the drawing figure to which the discussion is focused. In the present disclosure, the term “pet waste” refers to pet droppings (feces) but may include other pet waste materials including vomit or vector-carrying objects retrieved by the pet including vermin, etc.

Preferably, pet-debris scooper 102 comprises a device for picking up solid objects, such as pet debris and pet waste 104, and automatically sealing such pet waste 104 within a disposable liner. Preferably, pet-debris scooper 102 (at least embodying herein at least one grasper adapted to grasp the pet waste) comprises an elongated handle 106 supporting a pair of opposing scoops identified herein as scoop 108 and scoop 110, as shown. Preferably, scoop 108 and scoop 110 are movably joined to handle 106 by at least one pivoting coupler 109, as shown (at least embodying herein wherein such at least one first containment wall is movably positionable relative to such at least one second containment wall). Preferably, pivoting coupler 109 is adapted to allow the two scoops to articulate in a “clamshell-like” manner, as shown. When scoop 108 and scoop 110 are downwardly pivoted into an adjacent position, the two halves form a substantially enclosed container 112 (at least embodying herein wherein such at least one first containment wall and at least one second containment wall are together adapted to comprises at least one substantially enclosable interior portion). Preferably, scoop 108 and scoop 110 each comprise a generally concave inner surface, as shown. In the example embodiment of the present invention, scoop 108 and scoop 110 resemble half-cylinders. Upon reading the teachings of this specification, those of ordinary skill in the art will now understand that, under appropriate circumstances, considering such issues as intended use, cost, user preference, etc., other scoop shape arrangements, such as, for example, square, triangular, and similar geometric shapes, half-spheres, complex shapes including free-form surfaces, etc., may suffice.

Preferably, container 112 (see FIG. 2) is biased to the normally open position of FIG. 1, preferably by the application of spring tension or the application of a tension force by a similar tensioning mechanism, diagrammatically illustrated as biasing element 114, as shown. Biasing element 114 is illustrated by a single line of tension force applied to the upper portions of scoop 108 and scoop 110, as shown. Preferably, biasing element 114 is adapted to supply a tensioning force resulting in the upward pivoting of scoop 108 and scoop 110

6

about pivoting coupler 109, as shown. Upon reading the teachings of this specification, those of ordinary skill in the art will now understand that, under appropriate circumstances, considering such issues as intended use, design preference, etc., other biasing arrangements, such as, for example, biasing scoops to a normally closed position, etc., may suffice.

Preferably, handle 106 comprises an upper gripping-portion 116 adapted to assist user gripping of pet-debris scooper 102, during use, as described herein (at least embodying herein wherein such at least one grasper comprises at least one hand grip to assist hand gripping of such at least one grasper during such applying of the at least one liner to such at least one grasper and during such grasping of the pet waste by such at least one grasper). In addition, gripping-portion 116 preferably comprises at least one manually actuated control adapted to control the closing of scoop 108 and scoop 110. Preferred control arrangements are discussed further in FIG. 6A and FIG. 6B.

Preferably, the interiors of scoop 108 and scoop 110 (at least embodying herein at least one first containment wall and at least one second containment wall) are preferably fitted with disposable liner 118 prior to use, as shown (at least embodying herein wherein such at least one substantially enclosable interior portion is adapted to receive at least one liner portion of such at least one liner). Preferably, disposable liners 118 are specifically designed for use with pet-debris scooper system 100 and are preferably constructed of lightweight and flexible material with a sheet plastic being most preferred. Preferably, disposable liner 118 is adapted to form a bag-like covering to surround and encapsulate pet waste 104 prior to disposal (as shown in FIG. 2). In addition, disposable liner 118 functions as a barrier to protect pet-debris scooper 102 from soiling by pet waste 104 during collection. Preferably, the peripheral ends of the liner are attached to the outside of scoop 108 and scoop 110, as shown. Most preferably, the peripheral edge 120 of disposable liner 118 comprises an adhesive strip 122 adapted to adhere the edge of disposable liner 118 to scoop 108 and scoop 110, most preferably to the external surfaces of scoop 108 and scoop 110, as shown (at least embodying herein wherein such at least one liner comprises at least one releasable adhesive adapted to releasably adhere the at least one liner to such at least one first containment wall and such at least one second containment wall). Preferably, disposable liner 118 is retained to the interior of container 112 by liner-clamping assembly 124, as shown (at least embodying herein wherein such at least one grasper further comprises at least one liner retainer adapted to retain such at least one liner portion of such at least one liner; and such at least one liner retainer is positioned substantially within such at least one substantially enclosable interior portion). The preferred arrangements and operation of liner-clamping assembly 124 are discussed in detail in FIG. 4 through FIG. 5D, below.

FIG. 2 shows a partial side view of pet-debris scooper 102 in a closed position according to the preferred embodiment of FIG. 1. Specific reference is now made to FIG. 2, with continued reference to FIG. 1. Preferably, to collect pet waste 104 for disposal, user 101 positions scoop 108 and scoop 110 over pet waste 104 and manipulates manually actuated control 126 to pivot scoop 108 and scoop 110 to a closed position, as shown. In the preferred embodiment of FIG. 1, manually actuated control 126 comprises a tensioning member 125 adapted to apply a pulling force to the lever arms 128 of scoop 108 and scoop 110, as shown. Preferably, application of such a tensional force (whereby tensioning member 125 is drawn upwardly from about reference position A to about reference position B) results the development of torque forces about the

common fulcrum point located at pivoting coupler **109**. When the developed torque exceeds the tensional force of biasing element **114**, scoop **108** and scoop **110** rotate to enclose pet waste **104**. Upon reading the teachings of this specification, those of ordinary skill in the art will now understand that, under appropriate circumstances, considering such issues as intended use, design preference, cost, etc., other arrangements adapted to form an essentially enclosed container, such as, for example, the use of multiple pivot points, hinges, tracks, guides, flexible or deformable scoops, etc., may suffice. It is noted that the configuration and operation of alternate pivoting clamshell arrangements, adaptable for use with the present invention, are described in greater detail in, for example, U.S. Pat. No. 5,601,321 to Simon, incorporated herein by reference for further examples of implementation engineering.

Preferably, closing scoop **108** and scoop **110** encapsulates pet waste **104** within the attached disposable liner **118**, as shown. Preferably, disposable liner **118** comprises a self-sealing feature adapted to seal the material of disposable liner **118** along points of inter-contact, preferably along the lines of contact between scoop **108** and scoop **110**, adjacent peripheral edges **120**, as shown.

FIG. 3 shows a partial side view of pet-debris scooper **102** and continued illustration of the preferred methods of use. Referring now to both FIG. 2 and FIG. 3, when pet-debris scooper **102** is closed, an operable control located in handle **106** draws a liner gripping portion of liner-clamping assembly **124** upward, releasing adhesive strips **122** from the external surfaces of the scoops, while pulling the attached disposable liner **118** into container **112**, as shown. As peripheral edges **120** of disposable liner **118** are drawn between scoop **108** and scoop **110**, the edges seal together forming a substantially closed liner, as shown (at least embodying herein wherein such at least one liner retainer comprises at least one puller adapted to pull such at least one liner into such at least one substantially enclosable interior portion; and such pulling of such at least one liner into such at least one substantially enclosable interior portion detaches such at least one liner from such at least one first containment wall and such at least one second containment wall). As disposable liner **118** (now substantially sealed) continues to be pulled further into container **112**, disposable liner **118** is drawn against barrier **130**. Preferably, barrier **130** pulls disposable liner **118** away from liner-clamping assembly **124**, allowing disposable liner **118** to fall free from container **112** when scoop **108** and scoop **110** are opened, as shown (at least embodying herein at least one releaser adapted to release such at least one liner from such at least one liner retainer; and such at least one releaser is controlled by such pulling of such at least one liner by such at least one puller). Preferably, peripheral edges **120** of disposable liner **118** do not come in contact with pet waste **104** during the collection and encapsulation process, thus, there is no waste residue on the outside of disposable liner **118** after release. Once released, from the interior of container **112**, the now-sealed disposable liner **118** is easily collected and removed for disposal. Pet-debris scooper **102**, on discharging the sealed disposable liner **118**, is ready for the fitting of a new disposable liner **118** (as described in FIG. 7A).

Preferably, disposable liner **118** comprises a self-sealing feature adapted to seal the material of disposable liner **118** along points of inter-contact, preferably along the lines of contact between scoop **108** and scoop **110**, as shown (at least embodying herein wherein such at least one liner comprises at least one sealer structured and arranged to seal such at least one liner substantially around the pet waste; and wherein such at least one sealer is adapted to be assisted in such sealing of

such at least one liner substantially around the pet waste by such pulling of such at least one liner into such at least one substantially enclosable interior portion). Preferred materials suitable for use in the fabrication of disposable liner **118** include self-sealing materials comprising flexible films coated with pressure sensitive adhesive for releasable seating to a target surface (in this case pet-debris scooper **102**), and more particularly films which have features for preventing premature sticking to a target surface during storage and positioning of the film. Films suitable for use in fabrication of disposable liner **118** include materials produced by The Procter & Gamble Company of Cincinnati, Ohio utilizing a "Griptex-like" technology. It is noted that the structures and formulation of such films, adaptable for use with the present invention, are described in greater detail in, for example, U.S. Pat. No. 6,489,022 to Hamilton et al., incorporated herein by reference for further examples of implementation engineering. Alternate preferred sealing methodologies are presented in FIG. 8A and FIG. 8B below.

FIG. 4 shows a partial side view diagrammatically illustrating the preferred arrangements of liner-clamping assembly **124** according to the preferred embodiment of FIG. 1. Preferably, liner-clamping assembly **124** comprises liner clamp **132**, barrier **130** and spring **134**, as shown. Preferably, liner-clamping assembly **124** is centrally mounted to the fixed (non-articulating) structures of pet-debris scooper **102**. Preferably, spring **134** is adapted to maintain liner clamp **132** in a position of intersection with barrier **130**, as shown. Preferably, liner clamp **132** is mounted to allow translational movement relative to barrier **130**. Preferably, movement of liner clamp **132** is enabled by control rod **138** extending from within handle **106** to couple with liner clamp **132**, as shown. Preferably, control rod **138** is adapted to draw liner clamp **132** upwardly through barrier **130** as described below.

FIG. 5A shows the detail view 5A-5A of FIG. 4 generally illustrating the configuration of liner-clamping assembly **124**. FIG. 5A shows liner-clamping assembly **124** in a preferred resting position with the opposing jaws **140** of liner clamp **132** intersecting the line of barrier **130**, as shown. Preferably, the opposing jaws **140** are held together by at least one opposing force, preferably supplied by clamp spring **142**, as shown. Upon reading the teachings of this specification, those of ordinary skill in the art will now understand that, under appropriate circumstances, considering such issues as intended use, design preference, etc., other methods of applying an opposing force to the opposing jaws, such as, for example, a force applied by interaction with the barrier, etc., may suffice. Preferably, clamp spring **142** draws the two opposing jaws **140** shut, creating the action necessary for gripping disposable liner **118** (for clarity, it is helpful to visualize the configuration of a modified spring-type clothespin). Upon reading the teachings of this specification, those of ordinary skill in the art will now understand that, under appropriate circumstances, considering such issues as intended use, configuration of liner, etc., other liner clamping arrangements, such as, for example, adhesives, rollers, hook-and-loop-type temporary fasteners, etc., may suffice.

FIG. 5B shows the detail view of FIG. 5A depicting liner-clamping assembly **124** engaging disposable liner **118** of pet-debris scooper system **100**. To connect disposable liner **118** to liner-clamping assembly **124**, liner clamp **132** is lowered to engage a specially designed disposable-liner dispenser **144** (see FIG. 7A). Preferably, disposable-liner dispenser **144** is adapted to dispense a single disposable liner **118** from a stack of disposable liners **118**, as shown. Pressing liner clamp **132** over clamp engaging point **146** of disposable-liner

dispenser **144** results in the opening of the two opposing jaws **140** to situate the uppermost disposable liner **118** in a graspable position, as shown.

FIG. 5C shows the detail view of FIG. 5A with liner-clamping assembly **124** gripping the disposable liner **118** of FIG. 5B. Preferably, pulling liner clamp **132** away from clamp engaging point **146** allows the two opposing jaws **140** to shut, gripping disposable liner **118**, as shown. Barrier **130** is preferably configured to accommodate the opening and closing of opposing jaws **140**, as shown.

FIG. 5D shows the detail view of FIG. 5A with disposable liner **118** passing through release barrier **130** adapted to release disposable liner **118** from liner-clamping assembly **124**. Preferably, control rod **138** is adapted to draw liner clamp **132** upwardly through barrier **130**, as shown. Preferably, the preferred design of liner-clamping assembly **124** is such that barrier **130** allows the passage of liner clamp **132** and resists the passage of disposable liner **118**. Preferably, barrier **130** comprises one or more non-moving members that are preferably maintained in a substantially fixed positioning within container **112**, as shown. As liner clamp **132** passes through barrier **130**, disposable liner **118** is drawn against barrier **130**, as shown. Preferably, as barrier **130** resists the passage of disposable liner **118**, disposable liner **118** is pulled away from liner clamp **132**, allowing disposable liner **118** to fall free. Preferably, to assist in removal, the upper portion of disposable liner **118** comprises a generally stiff physical structure (similar in consistency to the sealing portion of a zip-lock-type bag). Preferably, pulling disposable liner **118** past barrier **130** is sufficient to pull disposable liner **118** away from liner clamp **132**. Upon reading the teachings of this specification, those of ordinary skill in the art will now understand that, under appropriate circumstances, considering such issues as design preference, cost, service, etc., other barrier configurations, such as, for example, the use of a movable barrier using one-way rollers that contact the liner and restrict upward liner movement while allowing free downward liner movement, in combination with low friction surfaces at the liner clamp, etc., may suffice.

Preferably, on releasing the tension from control rod **138**, liner clamp **132** is returned to the resting position of FIG. 5A by a return force supplied by clamp spring **142**, as shown.

Once barrier **130** has pulled disposable liner **118** away from liner-clamping assembly **124**, disposable liner **118** is free to fall away from container **112** when scoop **108** and scoop **110** are opened. Preferably, peripheral edges **120** of disposable liner **118** do not come in contact with pet waste **104** during the collection and encapsulation process, thus, there is no waste residue on the outside of disposable liner **118** after release. Once released, from the interior of container **112**, the now-sealed disposable liner **118** is easily collected and removed for disposal. Pet-debris scooper **102**, on discharging the sealed disposable liner **118**, is ready for the fitting of a new disposable liner **118** (as described in FIG. 7A).

FIG. 6A shows a partial side view of handle **106** depicting a preferred embodiment of gripping-portion **116** identified herein as handgrip assembly **150**. FIG. 6B shows a partial side view of handle **106** depicting another preferred embodiment of gripping-portion **116** identified herein as handgrip assembly **152**. In addition to providing a gripping surface for the manipulation of pet-debris scooper **102**, gripping-portion **116** preferably comprises at least one manually actuated control adapted to control the closing of scoop **108** and scoop **110**, as previously described. In the example depiction of FIG. 6A, handgrip assembly **150** comprises a sliding handle arrangement adapted to slide along handle **106**, as shown. Preferably, tensioning member **125** is coupled to the moving portion of

handgrip assembly **150**, as shown. Preferably, the upward movement of handgrip assembly results in the upward movement of tensioning member **125** resulting in the closing of scoop **108** and scoop **110**.

Furthermore, upon reading the teachings of this specification, those of ordinary skill in the art will now appreciate that, under appropriate circumstances, it is possible to develop preferred actuation arrangements that also function to engage (sequentially) control rod **138**, thus enabling in a single movement, an uptake of liner clamp **132** following the closure of the scoops. These preferred in arrangements may preferably include the use of resilient members **154** at part of tensioning member **125**, as shown.

Handgrip assembly **152** of FIG. 6B preferably comprises a pivoting trigger-type arrangement with a separate control **156** for operating liner-clamping assembly **124**, as shown. Preferably, handgrip assembly **152** comprises pivoting member **158** couple to tensioning member **125**, as shown. Preferably, hand squeezing pivoting member **158** induces a generally vertical movement in tensioning member **125**.

Preferably, both handgrip assembly **150** and handgrip assembly **152** are adaptable to include at least one releasable retainer **160** adapted to retain tensioning member **125** in a position maintaining the closing of scoop **108** and scoop **110** (thus allowing users to release their grip while maintaining container **112** in a closed condition until arriving at a suitable disposal location). Upon reading the teachings of this specification, those of ordinary skill in the art will now understand that, under appropriate circumstances, considering such issues as user preference, intended use, etc., other gripping and control arrangements, such as twisting actuators, pneumatic controls, compression-based operators, additional ergonomic grips, the use of resilient padding, etc., may suffice.

FIG. 7A shows side view depicting disposable-liner dispenser **144** according to a preferred embodiment of the present invention. Preferably, disposable-liner dispenser **144** is adapted to apply, essentially automatically, a single disposable liner **118** to pet-debris scooper **102** by a simple press-and-release movement. A second important function of disposable-liner dispenser **144** is that of a holder to provide proper positioning and alignment of pet-debris scooper **102** within disposable-liner dispenser **144** during the application of a disposable liner **118**. A third important function of disposable-liner dispenser **144** is that of a refillable holder to hold a plurality of disposable liners **118** (enabling multiple applications of a single liner). Yet another function of disposable-liner dispenser **144** is that of a holder providing convenient vertical storage of pet-debris scooper **102** between uses (at least embodying herein at least one holding component adapted to hold such at least one grasper; wherein such at least one holding component comprises at least one holder adapted to hold the at least one liner; wherein such at least one holding component further comprises at least one applicator adapted to apply the at least one liner to such at least one grasper).

Preferably, disposable-liner dispenser **144** is mechanically actuated without the use of electrically powered components. Upon reading the teachings of this specification, those of ordinary skill in the art will now understand that, under appropriate circumstances, considering such issues as intended use, cost, etc., other actuation arrangements, such as, for example, the use of electrically powered components, etc., may suffice. Preferably, disposable-liner dispenser **144** adapted to rest on a generally horizontal support surface, most preferably a floor surface, as shown. Upon reading the teachings of this specification, those of ordinary skill in the art will now understand that, under appropriate circumstances, considering such

issues as intended use, size of unit, user preference, etc., other support arrangements, such as, for example, wall mounts, vehicle storage mounts, etc., may suffice.

FIG. 7B shows a diagrammatic sectional view depicting the internal functional components of disposable-liner dispenser 144. Preferably, a stacked arrangement of disposable liners 118 are mounted on a specially shaped applicator platform 160 located within disposable-liner dispenser 144, as shown. Preferably, applicator platform 160 comprises the clamp engaging point 146 described in FIG. 5B (at least embodying herein at least one positional director adapted to positionally direct such at least one liner to at least one retainable position adjacent such at least one liner retainer).

When pet-debris scooper 102 (without a liner attached), is placed onto disposable-liner dispenser 144, one disposable liner 118 attaches itself to scoop 108 and scoop 110 by means of adhesive strip 122 located along the peripheral edges 120 of disposable liner 118, as shown. At substantially the same time, engaging point 146 forces jaws 140 of liner clamp 132 apart, pushing disposable liner 118 into liner clamp 132 (when pet-debris scooper 102 is removed from disposable-liner dispenser 144, liner clamp 132 grabs and retains disposable liner 118 as described in FIG. 5C and FIG. 5D). Preferably, L-shaped pivoting members 162 are located on each side of applicator platform 160, as shown. Preferably, L-shaped pivoting members 162 are adapted to assist in pressing adhesive strip 122 to the external surfaces of the scoops (at least embodying herein wherein such at least one applicator is adapted to assist in adhering such at least one releasable adhesive of such at least one liner to such at least one first containment wall and such at least one second containment wall).

FIG. 7C shows the detail view 7C-7C of FIG. 7B illustrating adhesive strip 122 of peripheral edge 120. Preferably, the upper side of peripheral edge 120 comprises adhesive strip 122, as shown. Preferably, the opposite (lower) side of peripheral edge 120 comprises adhesive-resisting area 164, as shown. Preferably, adhesive-resisting area 164 comprises a surface resisting the adhesive quality of adhesive strip 122. This preferred arrangement prevents individual liners from adhering to each other while stored within disposable-liner dispenser 144, as shown. The above-described arrangements at least embody herein wherein such at least one liner further comprises at least one periphery comprising at least one first peripheral side and at least one second peripheral side; such at least one first peripheral side comprises such at least one releasable adhesive; such at least one second peripheral side comprises at least one adhesive resistor adapted to resist adherence of such at least one releasable adhesive; and at least one such at least one liner is stackable over at least one other such at least one liner without adherence between such at least one first peripheral side and such at least one second peripheral side.

FIG. 7D shows a diagrammatic sectional view depicting the application of disposable-liner 118 to pet-debris scooper 102. FIG. 7D also depicts the preferred vertical storage position of pet-debris scooper 102 within disposable-liner dispenser 144.

Preferably, L-shaped pivoting members 162, which are mounted on the edge of applicator platform 160, pivot when pet-debris scooper 102 is lowered into contact, as shown. Preferably, the generally vertical legs of L-shaped pivoting members 162 rotate toward pet-debris scooper 102 to push the adhesive strips 122 of the disposable liner 118 (nearest to pet-debris scooper 102) onto the outer surfaces of scoop 108 and scoop 110, resulting in the attachment of the liner, as shown.

FIG. 7E shows a diagrammatic sectional view depicting the pet-debris scooper 102 after a preferred application of disposable-liner 118. Preferably, the periphery of disposable liner 118 is adhered to the outer surfaces of scoop 108 and scoop 110 while the middle of disposable-liner 118 is gripped by liner-clamping assembly 124, as shown.

FIG. 8A shows a diagrammatic sectional view depicting the disposable-liner dispenser 144 of FIG. 7A comprising an alternate internal component assembly 170 according to another preferred embodiment of the present invention. FIG. 8B shows a diagrammatic sectional view depicting the application of a disposable-liner to the pet-debris scooper using the alternate internal component assembly 170 of 8A. Both FIG. 8A and FIG. 8B illustrate an alternate arrangement for the application and sealing of disposable liner 118.

In the present preferred embodiment, each side of peripheral edge 120 (of disposable liner 118) comprises an adhesive strip 122, as shown. Preferably, a removable protective strip 172 is applied over peripheral edges 120 to cover simultaneously both adhesive strips 122 during storage (at least embodying herein such at least one liner further comprises at least one removable cover adapted to removably cover such at least one releasable adhesive during storage). Preferably, alternate internal component assembly 170 comprises a set of T-shaped engagers 174 adapted to frictionally engage and remove the adhesive strips 122 as pet-debris scooper 102 is pressed downward into alternate internal component assembly 170 (at least embodying herein wherein such at least one applicator is adapted to remove such at least one removable cover prior to adherence of such at least one liner to such at least one first containment wall and such at least one second containment wall). Preferably, each T-shaped engager 174 is movably mounted within alternate internal component assembly 170, as shown. Preferably, downward contact by pet-debris scooper 102 on T-shaped engagers 174 moves the T-shaped engagers 174 in contact with the removable protective strips 172, as shown. When pet-debris scooper 102 is sufficiently engaged within alternate internal component assembly 170, protective strips 172 are pulled clear of disposable liner 118 to expose adhesive strips 122, as shown.

Preferably, the upper adhesive strips 122 functions to adhere disposable liner 118 to scoop 108 and scoop 110, as shown. The lower adhesive strips (located on the opposite side of peripheral edge 120) preferably function to seal together the peripheral edges 120 of disposable liner 118 on the closing of scoop 108 and scoop 110. Upon reading the teachings of this specification, those of ordinary skill in the art will now understand that, under appropriate circumstances, considering such issues as user preference, intended use, etc., the use of additional enabling features, such as one-way rollers, return springs, guide slots, resilient contact pads, etc., may suffice.

Preferably, alternate internal component assembly 170 also comprises a modified applicator platform 178, as shown. Preferably, applicator platform 178 comprises the clamp engaging point 146 described in FIG. 5B.

FIG. 9 shows a preferred kit system 180 according to a preferred embodiment of the present invention. Preferred embodiments of pet-debris scooper system 100 are adaptable to comprise a consumer kit. Preferably, such a kit is offered containing the basic elements needed to use and operate pet-debris scooper system 100.

Preferably, kit system 180 comprises pet-debris scooper 102, disposable-liner dispenser 144, and instructions for use 182, as shown. In addition, preferred embodiments of kit

13

system **180** comprise at least one disposable liner **118**, most preferably a package **184** comprising a plurality of disposable liners **118**, as shown.

Upon reading the teachings of this specification, those of ordinary skill in the art will now understand that, under appropriate circumstances, considering such issues as user preference, intended use, etc., other kit arrangements, such as including consumer packaging, instructions comprising video media, accessories such a portable liner applicator, kids comprising advertising indicia or indicia tied to a specific pet breed, etc., may suffice.

Although applicant has described applicant's preferred embodiments of this invention, it will be understood that the broadest scope of this invention includes modifications such as diverse shapes, sizes, and materials. Such scope is limited only by the below claims as read in connection with the above specification. Further, many other advantages of applicant's invention will be apparent to those skilled in the art from the above descriptions and the below claims.

What is claimed is:

1. A method related to the collection of at least one pet waste item using at least one hand-holdable grasper comprising the steps of:

- a) providing at least one disposable liner adapted to resist the passage of the pet waste;
- b) providing at least one applicator adapted to apply such at least one disposable liner to such at least one hand-holdable grasper;
- c) loading at least one first at least one disposable liner onto such at least one applicator;
- d) loading such at least one hand-holdable grasper onto such at least one applicator, wherein such at least one first at least one disposable liner becomes attached to such at least one hand-holdable grasper; and
- e) removing from such at least one applicator, such at least one hand-holdable grasper comprising such at least one first at least one disposable liner.

2. The method according to claim **1** further comprising the step of grasping the at least one pet waste item with such at least one hand-holdable grasper comprising such at least one first at least one disposable liner, wherein such at least one first at least one disposable liner substantially encapsulates the at least one pet waste item.

3. The method according to claim **1** further comprising the step of releasing such at least one first at least one disposable liner from such at least one hand-holdable grasper, wherein such at least one first at least one disposable liner substantially encapsulates the at least one pet waste item.

4. The method according to claim **1** further comprising the step of loading such at least one hand-holdable grasper onto such at least one applicator, wherein at least one second at least one disposable liner is attached to such at least one hand-holdable grasper.

5. A system related to the collection and encapsulation of pet waste within at least one liner comprising at least one membrane substantially impermeable to the pet waste, said system comprising:

- a) at least one grasper adapted to grasp the pet waste;
- b) at least one holding component adapted to hold said at least one grasper;
- c) wherein said at least one holding component comprises at least one holder adapted to hold the at least one liner;
- d) wherein said at least one holding component further comprises at least one applicator adapted to apply the at least one liner to said at least one grasper; and
- e) wherein said at least one grasper comprises at least one hand grip to assist hand gripping of said at least one

14

grasper during such applying of the at least one liner to said at least one grasper and during such grasping of the pet waste by said at least one grasper.

6. The system according to claim **5** further comprising:

- a) such at least one liner;
 - b) wherein said at least one liner comprises at least one membrane substantially impermeable to the pet waste; and
 - c) wherein said at least one membrane is substantially flexible.
- 7.** The system according to claim **6** wherein:
- a) said at least one grasper comprises at least one container adapted to contain the pet waste;
 - b) said at least one container comprises at least one first containment wall and at least one second containment wall;
 - c) said at least one first containment wall is movably positionable relative to said at least one second containment wall;
 - d) said at least one first containment wall and at least one second containment wall are together adapted to comprises at least one substantially enclosable interior portion; and
 - e) said at least one substantially enclosable interior portion is adapted to receive at least one liner portion of said at least one liner.

8. The system according to claim **7** wherein:

- a) said at least one liner comprises at least one releasable adhesive adapted to releasably adhere the at least one liner to said at least one first containment wall and said at least one second containment wall; and
- b) said at least one applicator is adapted to assist in adhering said at least one releasable adhesive of said at least one liner to said at least one first containment wall and to said at least one second containment wall.

9. The system according to claim **8** wherein:

- a) said at least one grasper further comprises at least one liner retainer adapted to retain said at least one liner portion of said at least one liner; and
- b) said at least one liner retainer is positioned substantially within said at least one substantially enclosable interior portion.

10. The waste collection system, according to claim **9** wherein:

- a) said at least one liner retainer comprises at least one puller adapted to pull said at least one liner into said at least one substantially enclosable interior portion; and
- b) such pulling of said at least one liner into said at least one substantially enclosable interior portion detaches said at least one liner from said at least one first containment wall and said at least one second containment wall.

11. The system, according to claim **10** wherein:

- a) said at least one liner comprises at least one sealer structured and arranged to seal said at least one liner substantially around the pet waste; and
- b) wherein said at least one sealer is adapted to be assisted in such sealing of said at least one liner substantially around the pet waste by such pulling of said at least one liner into said at least one substantially enclosable interior portion.

12. The system, according to claim **11** wherein said at least one sealer comprises at least one contact adhesive.

13. The system, according to claim **11** wherein said at least one sealer comprises at least one self-sealing material comprising at least one flexible film coated with at least one pressure sensitive adhesive adapted to self-seal by at least one application of mechanical pressure.

15

14. The system according to claim 11 further comprising:

- a) at least one releaser adapted to release said at least one liner from said at least one liner retainer; and
- b) said at least one releaser is controlled by such pulling of said at least one liner by said at least one puller.

15. The system according to claim 11 wherein:

- a) said at least one hand grip comprises at least one elongated handle adapted to support said at least one first containment wall and said at least one second containment wall;
- b) said at least one first containment wall and said at least one second containment wall each comprise at least one generally scoop-shaped member; and
- c) at least one of said at least one generally scoop-shaped member comprises at least one pivoting coupler adapted to movably join at least one of said at least one generally scoop-shaped members to said at least one elongated handle.

16. The system according to claim 15 wherein said at least one substantially enclosable interior portion of said at least one container is formable by the positioning of at least one of said at least one generally scoop-shaped members adjacent at least one other said at least one generally scoop-shaped members.

17. The system according to claim 9 wherein said at least one applicator further comprises at least one positional director adapted to positionally direct said at least one liner to at least one retainable position adjacent said at least one liner retainer.

18. The system according to claim 8 wherein:

- a) said at least one liner further comprises at least one removable cover adapted to removably cover said at least one releasable adhesive during storage; and
- b) said at least one applicator is adapted to remove said at least one removable cover prior to adherence of said at

16

least one liner to said at least one first containment wall and said at least one second containment wall.

19. The system according to claim 8 wherein:

- a) said at least one liner further comprises at least one periphery comprising at least one first peripheral side and at least one second peripheral side;
- b) said at least one first peripheral side comprises said at least one releasable adhesive;
- c) said at least one second peripheral side comprises at least one adhesive resistor adapted to resist adherence of said at least one releasable adhesive; and
- d) at least one said at least one liner is stackable over at least one other said at least one liner without adherence between said at least one first peripheral side and said at least one second peripheral side.

20. A kit system related to the collection and encapsulation of pet waste within, said system comprising:

- a) at least one grasper adapted to grasp the pet waste
 - i) wherein said at least one grasper comprises at least one hand grip to assist hand gripping of said at least one grasper during such grasping of the pet waste by said at least one grasper;
- b) at least one holding component adapted to hold said at least one grasper
 - i) wherein said at least one holding component comprises at least one holder adapted to hold at least one liner, and
 - ii) wherein said at least one holding component further comprises at least one applicator adapted to apply at least one liner to said at least one grasper;
- c) at least one set of user instructions for use; and
- d) at least one liner comprising at least one membrane substantially impermeable to the pet waste.

* * * * *