



INTERNATIONAL APPLICATION PUBLISHED UNDER THE PATENT COOPERATION TREATY (PCT)

<p>(51) International Patent Classification ⁶ : A61M 25/00</p>	<p>A1</p>	<p>(11) International Publication Number: WO 99/37348 (43) International Publication Date: 29 July 1999 (29.07.99)</p>
<p>(21) International Application Number: PCT/US98/01660 (22) International Filing Date: 23 January 1998 (23.01.98) (30) Priority Data: 09/010,876 22 January 1998 (22.01.98) US (71)(72) Applicant and Inventor: TAO, Jun [CN/US]; Suite 503, 2850 North 24th Street, Phoenix, AZ 85008 (US). (74) Agent: STONEMAN, Martin, L.; Stoneman Law Offices, Ltd., 211 East Osborn Road, Phoenix, AZ 85012 (US).</p>		<p>(81) Designated States: AU, CN, JP, KP, NZ, European patent (AT, BE, CH, DE, DK, ES, FI, FR, GB, GR, IE, IT, LU, MC, NL, PT, SE). Published <i>With international search report.</i></p>

(54) Title: CATHETER SYSTEM FOR IMPLANTING EMBRYOS

(57) Abstract

Described is a catheter system (20) for implanting embryos into a woman's uterus. The catheter system (20) utilizes a protective catheter sleeve (24) for introducing a catheter (25) into the uterus without mucus contamination of an inner catheter (25). Once the sleeve (24) containing the inner catheter (25) is introduced into the uterus, the protected inner catheter (25), carrying the embryos, is pushed through a swiveled distal end cap (32) on the sleeve (24) to a desired implanting location. The distal end of the inner catheter (25) has a protective cap (44) and a side opening (45) for embryo release. Features of the outer sleeve (24) and inner catheter (25) assist in ensuring a desired uterus location for implanting.

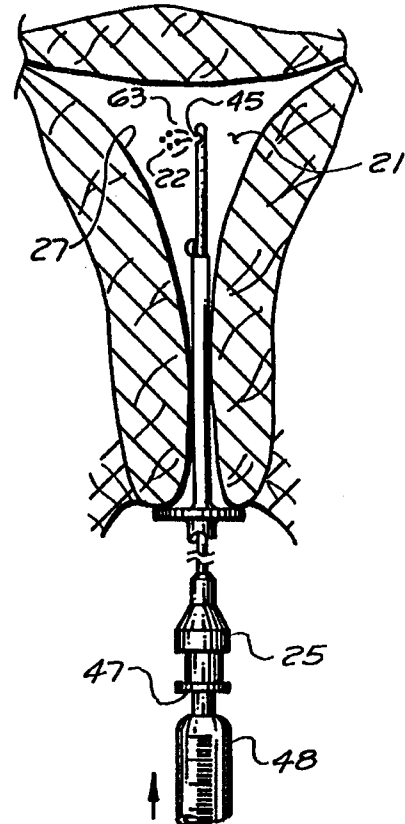

FOR THE PURPOSES OF INFORMATION ONLY

Codes used to identify States party to the PCT on the front pages of pamphlets publishing international applications under the PCT.

AL	Albania	ES	Spain	LS	Lesotho	SI	Slovenia
AM	Armenia	FI	Finland	LT	Lithuania	SK	Slovakia
AT	Austria	FR	France	LU	Luxembourg	SN	Senegal
AU	Australia	GA	Gabon	LV	Latvia	SZ	Swaziland
AZ	Azerbaijan	GB	United Kingdom	MC	Monaco	TD	Chad
BA	Bosnia and Herzegovina	GE	Georgia	MD	Republic of Moldova	TG	Togo
BB	Barbados	GH	Ghana	MG	Madagascar	TJ	Tajikistan
BE	Belgium	GN	Guinea	MK	The former Yugoslav Republic of Macedonia	TM	Turkmenistan
BF	Burkina Faso	GR	Greece	ML	Mali	TR	Turkey
BG	Bulgaria	HU	Hungary	MN	Mongolia	TT	Trinidad and Tobago
BJ	Benin	IE	Ireland	MR	Mauritania	UA	Ukraine
BR	Brazil	IL	Israel	MW	Malawi	UG	Uganda
BY	Belarus	IS	Iceland	MX	Mexico	US	United States of America
CA	Canada	IT	Italy	NE	Niger	UZ	Uzbekistan
CF	Central African Republic	JP	Japan	NL	Netherlands	VN	Viet Nam
CG	Congo	KE	Kenya	NO	Norway	YU	Yugoslavia
CH	Switzerland	KG	Kyrgyzstan	NZ	New Zealand	ZW	Zimbabwe
CI	Côte d'Ivoire	KP	Democratic People's Republic of Korea	PL	Poland		
CM	Cameroon	KR	Republic of Korea	PT	Portugal		
CN	China	KZ	Kazakstan	RO	Romania		
CU	Cuba	LC	Saint Lucia	RU	Russian Federation		
CZ	Czech Republic	LI	Liechtenstein	SD	Sudan		
DE	Germany	LK	Sri Lanka	SE	Sweden		
DK	Denmark	LR	Liberia	SG	Singapore		
EE	Estonia						

CATHETER SYSTEM FOR IMPLANTING EMBRYOS

CROSS REFERENCE TO RELATED APPLICATION

The present application is a continuation-in-part of U.S. application Serial No. 08/638,451 filed 04/26/96, abandoned in favor of this application.

BACKGROUND OF THE INVENTION

Field of the Invention

The invention relates to a catheter system for implanting embryos into a woman's uterus. More particularly, this invention concerns such a catheter system utilizing a protective catheter sleeve for introducing a catheter into the uterus without mucus contamination. And it concerns an improved catheter construction for embryo protection and deposit.

Description of the Prior Art

Typically, in present fertility clinics, three or four embryos are placed in a tiny, flexible catheter near the opening in the depositing end (the distal end) of the catheter. The catheter is then inserted through the woman's cervix and the embryos flushed hydraulically from the catheter and, hopefully, become implanted in the uterus wall. But the small catheter required is difficult to insert and mucus from the mouth of the cervix may be caught at the mouth of the catheter and interfere with the embryos. So, a stiffer and larger sleeve catheter may be used for insertion through the cervix; and then the smaller catheter may be pushed through and out the larger sleeve catheter to implant the embryos. This sleeve use helps, but cervix mucus may still be caught in the introduction end (the distal end) of the larger catheter and then transferred to the smaller catheter, thus still possibly interfering with the embryos.

The prior art includes some catheter-type devices for use in embryo implantation. In particular, Bacich U.S. Pat. No. 5,472,419 and Fischl U.S. Pat. No. 4,790,814 both employ the use of a catheter-type device, each having distal end openings to allow passage of the embryos to the uterus. Though these devices may be used for embryo implantation,

they do not adequately address the problem of preventing the accumulation of mucuslike material at the distal end opening, which may interfere with embryo implantation. Other embryo implanting devices employ the use of a catheter enclosed within an outer sleeve. For example, Wallace's GB No. 2,118,840 employs the use of an inner catheter slidable within an outer sleeve where the distal end of the outer sleeve is open. Though this device might also be suitable for embryo implantation, it fails to teach or implement an efficient way to protect against mucus accumulation within the outer sleeve during insertion. Other medical devices in fields other than embryo implantation employ the use of a catheter enclosed within an outer sleeve. For example, Pokorney U.S. Pat. No. 5,083,572 employs the use of an inner catheter slidable within an outer sleeve for use in obtaining vaginal secretions; but the purpose and construction are to bring in secretions/mucus within the outer sleeve, not to keep them out. And Pokorney's use of side sampling ports near the distal end of the outer sleeve do not prevent mucus accumulation within the outer sleeve nor does the sleeve permit the inner catheter to slide out of the sleeve to deposit an embryo or for any purpose whatsoever. O'Neil U.S. Pat. No. 4,652,259 is even further afield. It discloses a urinary catheter assembly and has to do with bacteria protection of the bladder in collecting urine, not mucus and embryo protection for transplanting. The sleeve is built for specific use only in the outer urethra and only the inner catheter is permitted to travel alone through the inner urethra and into the bladder for catheterization.

Thus there is a need for a catheter system for implanting embryos which will better protect the embryos from mucus and other damage in an efficient manner.

OBJECTS OF THE INVENTION

A primary object of the present invention is to fulfill the above-mentioned needs by the provision of an improved catheter system for implanting embryos. A further primary object of the present invention is to provide such a catheter

system which is efficient, inexpensive, and handy. Other objects of this invention will become apparent with reference to the following invention descriptions.

SUMMARY OF THE INVENTION

According to a preferred embodiment of the present invention, this invention provides a catheter system for assisting implanting embryos in a uterus, comprising: catheter sleeve means, having a sleeve distal end and a sleeve proximal end and having, between such sleeve distal end and such sleeve proximal end, a longitudinal cylindrical hollow having a central longitudinal axis, such catheter sleeve means being structured and arranged for containing an inner catheter in such cylindrical hollow, such catheter sleeve means comprising end cap means, disposed along an intersection of such central axis at such sleeve distal end, for substantially enclosing such cylindrical hollow at such sleeve distal end to protect such cylindrical hollow from accumulating mucuslike material when such catheter sleeve means is inserted into a such uterus, such end cap means comprising end opening means, disposed along such intersection of such central axis at such sleeve distal end, for permitting passage of an inner catheter along such central axis from within such cylindrical hollow into a such uterus; such catheter sleeve means being structured and arranged for insertion of such sleeve distal end into a such uterus for assistance in implanting embryos.

Further, this invention provides such a system wherein such end opening means of such sleeve distal end comprises swivel means constructed and arranged in such manner that such end cap means swivels outward when an inner catheter is pushed through such sleeve distal end; and, further, wherein such end cap means comprises an outwardly convex flexible end on such catheter sleeve means and such end cap opening means comprises a partial transverse cut separating, except for a remaining transverse hinge portion, such outwardly convex flexible end from such catheter sleeve means, whereby such end cap means is constructed and arranged to swivel outward

when an inner catheter is pushed through such sleeve distal end. And it provides such a system further comprising: an inner catheter means, having a catheter distal end and a catheter proximal end, for transporting a such embryo through such cylindrical hollow of such outer sleeve means into access to such uterus and for depositing such embryo in such uterus; and, further, wherein such inner catheter means comprises indicia means for indicating longitudinal distance to assist in attaining a desired implanting location.

Also, this invention provides such a system wherein such catheter distal end comprises: catheter distal opening means for depositing such embryo, such catheter distal opening means comprising a side port, adjacent such catheter distal end of such inner catheter means. And it provides such a system wherein such catheter distal end comprises: second end cap means at such catheter distal end for protecting such inner catheter means when such catheter distal end is pushed through such sleeve distal end; and catheter distal opening means for depositing such embryo, such catheter distal opening means comprising a side port adjacent such second end cap means at such catheter distal end of such inner catheter means; and, further, wherein such catheter distal end further comprises strengthening means opposite such catheter distal opening means for strengthening such inner catheter means against breakage. Also, it provides such a system wherein such end opening means at such sleeve distal end of such catheter sleeve means comprises swivel means constructed and arranged in such manner that such end cap means swivels outward when such catheter distal end is pushed through such sleeve distal end.

In addition, it provides such a system wherein such catheter sleeve means further comprises first stop means for limiting insertion to a desired location when such catheter sleeve means is inserted into a such uterus; and, further, wherein such inner catheter means further comprises second stop means settable along such inner catheter means for limiting insertion to a desired implanting location when such

inner catheter means is inserted into a such uterus. And it provides such a system wherein such catheter sleeve means further comprises stop means for limiting insertion to a desired location when such catheter sleeve means is inserted into a such uterus.

Even further, in accordance with a preferred embodiment thereof, the present invention provides a catheter system for implanting embryos in a uterus, comprising: a catheter outer sleeve having a longitudinal cylindrical hollow between a sleeve distal end and a sleeve proximal end, for providing safe catheter access to a such uterus by a catheter having a catheter distal end and a catheter proximal end; such sleeve distal end comprising an outwardly convex end cap, for protecting such cylindrical hollow from accumulating mucuslike material when such catheter outer sleeve is inserted into a such uterus, and an outwardly-swivelable connection between such end cap and such catheter outer sleeve, for permitting passage of a such catheter distal end from such cylindrical hollow into a such uterus when such catheter distal end is pushed against such end cap to swivel such end cap outwardly and move such catheter distal end through such sleeve distal end.

Even additionally, this invention provides such a system further comprising: an inner catheter means, having a catheter distal end and a catheter proximal end, for transporting a such embryo through such cylindrical hollow of such outer sleeve into access to such uterus and for depositing such embryo in such uterus. And it provides such a system wherein such catheter distal end comprises: an outwardly convex second end cap for protecting such inner catheter means when such catheter distal end is pushed through such sleeve distal end; and a catheter distal opening for depositing a such embryo, such catheter distal opening comprising a side port adjacent such second end cap. It also provides such a system further comprising: locating means for locating such catheter distal end in a such uterus, such locating means comprising first stop means on such catheter

outer sleeve for abutting a cervix entrance to such uterus, and second stop means settable along such inner catheter means for limiting insertion of such catheter distal end of such inner catheter means to a desired implanting location when such inner catheter means is inserted into a such uterus.

Moreover, according to a preferred embodiment of this invention, it provides a catheter system for implanting embryos in a uterus, comprising, in combination, the steps of: providing a catheter outer sleeve having a longitudinal cylindrical hollow between a sleeve proximal end and a sleeve distal end having an outwardly convex end cap and an outwardly-swivelable connection between such end cap and such catheter outer sleeve; providing a catheter having a catheter proximal end and a catheter distal end having an opening for transmission of a such embryo, such catheter being sized for moving through such longitudinal cylindrical hollow; loading at least one such embryo into such catheter distal end; placing such catheter into such sleeve proximal end of such catheter outer sleeve and moving such catheter forward until such catheter distal end is approaching such sleeve distal end; introducing such sleeve proximal end into a such uterus to a desired stop location; further moving such catheter forward into such end cap of such catheter outer sleeve, outwardly swiveling such end cap, and further moving such catheter distal end forward into such uterus to a desired implanting location; and flushing such embryo out of such catheter distal end.

It even further provides such a system wherein such catheter distal end of such catheter comprises: a second end cap for protecting such catheter when such catheter distal end is pushed through such sleeve distal end; and a catheter distal opening for depositing a such embryo, such catheter distal opening comprising a side port adjacent such second end cap; and, further, wherein: such catheter outer sleeve further comprises first stop means located along such catheter outer sleeve for limiting insertion to such desired

stop location when such catheter outer sleeve is inserted into a such uterus; and such catheter further comprises second stop means settable along such catheter for limiting insertion to such desired implanting location when such inner catheter means is inserted into a such uterus.

Even moreover, in accordance with a preferred embodiment thereof, this invention provides, for use in a catheter system for implanting embryos in a uterus, wherein the steps in such system include providing a catheter outer sleeve having a longitudinal cylindrical hollow between a sleeve proximal end and a sleeve distal end having an outwardly convex end cap and an outwardly-swivelable connection between such end cap and such catheter outer sleeve, providing a catheter having a catheter proximal end and a catheter distal end having an opening for transmission of a such embryo, such catheter being sized for moving through such longitudinal cylindrical hollow, loading at least one such embryo into such catheter distal end, placing such catheter into such sleeve proximal end of such catheter outer sleeve and moving such catheter forward until such catheter distal end is approaching such sleeve distal end, introducing such sleeve proximal end into a such uterus to a desired stop location, further moving such catheter forward into such end cap of such outer sleeve, outwardly swiveling such end cap, and further moving such catheter distal end forward into such uterus to a desired implanting location, and flushing such embryo out of such catheter distal end, a method of making such outwardly-swivelable connection between such end cap and such outer sleeve, comprising the steps of: providing an outwardly convex end portion at such sleeve distal end integral with such catheter outer sleeve; and cutting to partially sever such end portion from such catheter outer sleeve transversely just beneath such end portion around at least about 300 degrees of a circumference around such convex end portion; whereby an unsevered part of such end portion provides a hinge means comprising such outwardly-swivelable connection.

Also, this invention provides, in accordance with a preferred embodiment thereof, a catheter system for assisting implanting embryos in a uterus wherein such end opening means is a slit, normally closed but openable for permitting passage of a such inner catheter pushed along such central axis from within such cylindrical hollow into a such uterus. It also provides such a system wherein such end opening means of such sleeve distal end is a cross-cut slit, normally closed but openable for permitting passage of a such inner catheter pushed along such central axis from within such cylindrical hollow into a such uterus.

BRIEF DESCRIPTION OF THE DRAWINGS

FIG. 1 is a partial sectional elevation view illustrating a preferred embodiment of a catheter system for implanting embryos, according to the present invention, shown inserted into a woman's uterus.

FIG. 2 is an exploded elevation view of the catheter system.

FIG. 3 is an enlarged, fragmented elevation view, in cross section, of a preferred embodiment of the outer sleeve of the catheter system.

FIG. 4 is a enlarged elevation view of the introducing-implanting end of the outer sleeve.

FIG. 5 is a cross-section plan view of the outer sleeve through section 5-5 of Fig.4.

FIG. 6 is an enlarged perspective view of the outer sleeve end, shown in its open position.

FIG. 7 is an enlarged cross-sectional elevation view of the implanting end of the inner catheter.

FIG. 8 is an enlarged elevation view of the implanting end of the inner catheter.

FIG. 9 is a cross-section plan view of the inner catheter through section 9-9 of Fig. 8.

FIG. 10 is an enlarged cross-section partial elevation view showing the inner catheter within the outer sleeve at its implanting end.

FIG. 11 is a perspective view showing a second

embodiment of the implanting end of the inner catheter.

FIG. 12 is a perspective view showing a third embodiment of the implanting end of the inner catheter.

FIGS. 13 through 19 illustrate a preferred embodiment of the method of use of the catheter system of the present invention.

FIG. 20 is an enlarged elevation view of the introducing-implanting end of the outer sleeve illustrating alternate, but less preferred, embodiments of the end opening means.

FIG. 21 is a top view of the embodiments of FIG. 20 illustrating a first alternate embodiment of the end opening means.

FIG. 22 is a top view of the embodiments of FIG. 20 illustrating a second alternate embodiment of the end opening means.

DETAILED DESCRIPTION OF A PREFERRED EMBODIMENT AND THE BEST MODE OF PRACTICE

Shown in FIG. 1 is a preferred embodiment of the catheter system **20** of the present invention, shown inserted into the uterus **21** of a woman for the purpose of depositing embryos **22**. The catheter system **20** is comprised of catheter sleeve means embodied by catheter outer sleeve **24** and inner catheter means embodied by an inner catheter **25**. The outer sleeve **24** contains and protects the inner catheter **25** (the two being concentrically disposed), and the embryos **22** within, while the catheter system **20** is inserted into the vagina, through the cervix **26**, and into the uterus **21**. Then there is performed embryo depositing and placement at a predetermined depth (from the exterior of the cervix) **D1** within the uterus **21**. Once deposited within the uterus **21**, the embryos **22** will normally eventually attach to the uterus wall **27**.

The outer sleeve **24** is substantially tubular, as shown, and has a longitudinal round-cylindrical hollow **28** (having interior surface **30**) appropriately sized for loosely containing the inner catheter **25** and extending the full length of the outer sleeve **24** (i.e., from its distal or depositing end **31** to its proximal or manipulating end **40**).

Integral with the outer sleeve 24, and at its depositing end 31, is end cap means preferably embodied by a swivelable cap 32 which remains in a closed position 33 (see FIGS. 3, 4, and 10), closing, streamlining, and protecting the depositing end 31, and blocking the cylindrical hollow 28, until being pushed forwardly to an open position 34 by the extending movement of the inner catheter 25. The swivelable cap 32, while remaining in a closed position 33, protects the interior of the outer sleeve 24 at the depositing end 31 from accumulating deposits of mucus 35 when the outer sleeve 24 is inserted through the cervix 26.

The outer sleeve 24 incorporates a stop means embodied by a flange 36 extending outwardly perpendicular from the outer sleeve 24 and of a diameter suitable for providing a limiting stop 37 at the entrance 38 of the cervix 26, and thus controlling the depth D2 that the outer sleeve 24 can be inserted into the cervix 26. This depth D2 is greater than the distance required to pass through the cervix 26, but less than the depth desired for depositing the embryos 22. This portion of the outer sleeve 24 (which is inserted through the cervix 26 to depth D2), extending from flange 36 to the swivelable cap 32, is the insertable portion 29 which is relatively small in outside diameter and flexible enough for conforming to the shape of the cervical passage.

Extending from flange 36 toward the manipulating (proximal) end 40, the outer sleeve 24 incorporates an increased outer diameter 41 for added rigidity in controlling the insertion of the catheter system 20 of the preferred embodiment of the present invention into the cervix 26. Also incorporated as a feature of the increased outer diameter 41 portion, located near the manipulating end 40, is handle means 42 for convenience of grasping the outer sleeve 24. Located at the manipulating end 40 of the outer sleeve 24 is a second flange 43 useful (as will be described) for controlling the movement of the inner catheter 25 in providing the desired implanting depth D1.

The inner catheter 25 is a hollow, flexible, very-small-

diameter longitudinal tube, sized to fit, and be free to slide concentrically within, the longitudinal cylindrical hollow 28 of the outer sleeve 24 along its axis or centerline CL (see FIG. 3). At the depositing (distal) end 39, the inner catheter 25 preferably incorporates an integral domed end cap 44 with a side port 45 interconnecting to the round-cylindrical interior passage 57 of the inner catheter 25. At the manipulating (proximal) end 46 of the inner catheter 25 is a receiver 47 into which a syringe 48 may be inserted. In use, the distal or depositing end 39 of the inner catheter 25 is loaded with buffer solution and embryos, then inserted into the manipulating end 40 of the outer sleeve 24 far enough so that the depositing end 39 approaches but does not contact the swivelable cap 32 (in its normal closed position); thus the depositing end 39 of the inner catheter 25 is not yet protruding from the depositing end 31 of the outer sleeve 24. Based upon prior soundings of the depth of the uterus, the desired depth D1 at which the embryos are to be deposited is determined. The amount this depth D1 is greater than the distance D2 (that the insertable portion 29 of the outer sleeve 24 inserts into the cervix 26) determines the distance D3 that the inner catheter 25 will be required to extend beyond the end of the outer sleeve 24 for implanting. When this distance D3 is established and added to distance that the inner catheter 25 is short of exiting from the outer sleeve 24, a snug-fitting second stop means embodied by movable stop 50 is positioned on the inner catheter 25 a corresponding distance away from the second flange 43 of the outer sleeve 24.

The catheter system 20 is then inserted into the uterus 21 through the cervix 26. Any mucus 35 that the insertable portion 29 of the outer sleeve 24 encounters and picks up remains on its exterior. After the described preferred insertion of the insertable portion 29 of the outer sleeve 24 into the uterus, the inner catheter 25, held concentrically by the outer sleeve 24, is pushed forward along the axis or longitudinal centerline CL of the outer sleeve 24 the

distance available until the movable stop 50 contacts the outer sleeve's second flange 43. This forward concentric movement of the inner catheter 25 pushes its domed end cap 44 against the outer sleeve's swivelable cap 32 (situate also along the centerline CL of the outer sleeve 24), opening it, and allowing the inner catheter 25 to extend beyond the outer sleeve 24 to the depth D1. Any mucus 35 encountered and picked up by the outer sleeve 24 (especially at its swivelable cap 32) is pushed aside by the opening movement of the swivelable cap 32. Thus the inner catheter 25 in exiting from the interior of the outer sleeve 24 remains free of mucus 35. With the embryos 22, which are to be implanted, contained inside near the side port 45 at the depositing end 39 of the inner catheter 25, and the inner catheter 25 shielded from passing through an accumulation of mucus 35, the depositing of embryos 22 is not hindered by mucus 35. This arrangement embodies in this invention an end cap means, disposed along an intersection of such central axis at such sleeve distal end, for substantially enclosing such cylindrical hollow at such sleeve distal end to protect such cylindrical hollow from accumulating mucuslike material when such catheter sleeve means is inserted into a such uterus, such end cap means comprising end opening means, disposed along such intersection of such central axis at such sleeve distal end, for permitting passage of an inner catheter along such central axis from within such cylindrical hollow into a such uterus. Once the inner catheter 25 is positioned at depth D1, the embryos 22, in their buffer solution, are hydraulically flushed from the side port 45 by means of the syringe 48 (and the flow of liquid through the interior passage 57 in well-known ways). After the embryos 22 are deposited within the uterus 21, the catheter system 20 is withdrawn from the cervix 26, uterus 21 and the vagina.

FIG. 2 illustrates the relative proportions of the components of the catheter system 20, shown un-assembled, and composed of the outer sleeve 24, inner catheter 25 and the movable stop 50. Additionally illustrated in enlarged

shortened cross section in FIG. 3 is the outer sleeve 24. Its features include the insertable portion 29 extending from the depositing end 31, with the swivelable cap 32 located centrally at the axis or centerline CL, to the flange 36 whose upper surface is the limiting stop 37 to restrict further insertion into the cervix 26. Extending from the flange 36 to the manipulating end 40, the outer sleeve 24 is of increased outer diameter 41. At the manipulating end 40 is a second flange 43 for providing a gauging surface with which the movable stop 50 may make contact. The longitudinal round-cylindrical hollow 28 extends from depositing end 31 to manipulating end 40 along axis or centerline CL. Additionally located near the manipulating end 40 is a handle means 42 which is sized and shaped for convenient handling of the outer sleeve 24. The movable stop 50 is made of silicone and has an inside diameter that is sized for a snug fit over the outside diameter of the concentrically-located inner catheter 25. The fit allows the movable stop 50 to be positioned as required on the inner catheter 25, yet remain in that position during use. The inner catheter 25 has a depositing end 39 and at the opposite (proximal) end, a receiver 47 with an appropriately-sized internal socket for the snug-fitting attachment of a syringe. The proportional lengths of the outer sleeve 24 and the inner catheter 25 are such that a first person can insert and position the outer sleeve 24 within the patient and advance the inner catheter 25 while a second person can, from a convenient distance, handle the syringe 48 and perform the flushing of the embryos into the uterus.

In further description of the outer sleeve 24, in addition to FIG.3, the depositing end 31 is shown in elevation view in FIG. 4, in cross-section in FIG. 5 and in perspective in FIG. 6. The material from which the entire outer sleeve 24 is constructed could preferably be siliconized polyvinylchloride, plastisol polyvinyl, or polyethylene. Alternately, either the entire insertable portion 29, or the end 0.5-1.0 centimeter of the depositing

end 31 of the insertable portion 29 could be made of such just-mentioned material whereas the remainder of the outer sleeve 24 could be constructed of borosilicate. The insertable portion 29 preferably is about 1.8-2.0 millimeters in outside diameter with a length of about 3.5 centimeters. The increased outer diameter 41 portion is preferably about 4.0 millimeters in outside diameter. Extending concentrically the length of the outer sleeve 24, excepting the swivelable cap 32 at the depositing end 31, the interior diameter 30 of the cylindrical hollow 28 is preferably about 1.5 millimeters. In manufacture, the depositing end 31 could be initially completely blocked with an integral outwardly convex end (preferably hemispherical), then a very thin transverse cut 55 (see FIG. 4), made by laser, would be made, nearly severing the hemisphere (preferably around at least about 300 degrees of the circumference around the convex end), with the remaining un-severed portion forming the hinge 56. The cut 55, by laser, would extend roughly perpendicular to (no more slanted than about 60 degrees in the direction of swivel) and fully through the longitudinal cylindrical hollow 28 with the uncut amount being the hinge 56 as shown in cross-section in FIG. 5. Then the hemisphere, i.e. the swivelable cap 32, remaining intact and partially attached to the depositing end 31 of the insertable portion 29, in the closed position 33, blocks the interior of cylindrical hollow 28 until being forcibly moved to an open position 34 as shown in FIG. 6 (by the movement along the axis or centerline CL of the inner catheter 25).

Although the preferred configuration of the depositing end 31 of the outer sleeve 24 has been fully described, alternate (but less preferred) configurations can be used herein. For example, illustrated in FIG. 20 (in a view similar to that of FIG. 4 but without the transverse cut 55) is the outer sleeve 24 comprising an insertable portion 29 having an approximately hemispherical depositing end 31. Specifically illustrated in FIG. 20 is the first alternate embodiment of the end opening means embodied by a single cut

or slit **53** (**53A** in FIG. 21) on the hemispherical depositing end **31** of outer sleeve **24**. FIG. 21 is a top view illustrating the cut or slit **53A**. This embodies herein a system wherein such end opening means is a slit, normally closed but openable for permitting passage of a such inner catheter pushed along such central axis from within such cylindrical hollow into a such uterus. FIG. 22 is an alternate top view of FIG. 20 illustrating a second alternate embodiment of the end opening means which is embodied by a cross-cut slit **53B** on the hemispherical depositing end **31** of outer sleeve **24**. The single slit **53A** and the cross-cut slit **53B** in, respectively, the first and second alternate embodiments of the end opening means are normally closed to maintain a closed depositing end **31** along the axis or centerline **CL** but are openable when and if catheter distal end **39** is pushed through said sleeve distal end **31** (occurring also along axis or centerline **CL**). The second alternate embodiment embodies herein such a system wherein such end opening means of such sleeve distal end is a cross-cut slit, normally closed but openable for permitting passage of a such inner catheter pushed along such central axis from within such cylindrical hollow into a such uterus.

The inner catheter **25**, is a lengthy (preferably about 70 centimeters in overall length) flexible tube preferably constructed in one piece of teflon or polyethylene with about a 0.5 millimeter inside diameter and about a 1.2 millimeter outside diameter (with the exception, of course, of the described special features at both ends). At the manipulating end **46** is the receiver **47** for accepting a syringe **48** (see FIG. 1). At the depositing end **39** is a second end cap means embodied by a domed end cap **44** (roughly hemispherical for fending off mucus and pushing smoothly on swivelable cap **32**) and also catheter distal opening means embodied by side opening or port **45** for discharging the embryos to be deposited. With the depositing end **39** of the inner catheter **25** shown in longitudinal cross-section in

FIG. 7, the round domed end cap 44 is shown blocking the straight through flow path of the interior passage 57. Located through the side wall, directly under the domed end cap 44, is the side port 45, which is preferably a round opening which intersects with, and completes the interior passage 57 allowing a side discharge path. At the location on the inner catheter 25 opposite to where the side port 45 intersects the interior, structural strength is compromised, and as a preventative against breakage, strengthening means embodied by the strengthened intersection 58, radiused with additional material, is provided. In addition to adding strength, the intersection 58, being radiused, also provides for a smoother, more streamlined flow path. This helps in cleaning, loading and flushing the inner catheter 25.

In FIG. 8, the inner catheter 25 is shown rotated approximately 45 degrees with the side port 45 shown completing the flow path of the interior passage 57. Also shown are indicia means embodied by indicia or markings 60, which are evenly spaced and continue the full length on the exterior of the inner catheter 25. These markings 60 may be graduated divisions referring to the volume of the interior passage 57 beginning at the side port 45. Their use is described, for example, in FIGS. 14A-14C. Indicia means for indicating longitudinal distance to assist in attaining a desired implanting location, embodied by similar additional graduated markings 60 (see FIG. 13) referring to length may be included to establish the location at which the movable stop 50 is positioned to provide a given extension dimension of the inner catheter 25 from the end of the outer sleeve 24. A cross-section through the inner catheter 25 at the side port 45 location is shown in FIG. 9. The additional wall

thickness derived from the radiused intersection 58 is shown in location opposite the side port 45.

FIG. 10 illustrates in cross-section the depositing ends 31 of the outer sleeve 24, and within its cylindrical hollow 28, the inner catheter 25, both positioned approximately as they would be while being inserted into the desired uterus position. With the swivelable cap 32 in its normally closed position 33, the inner catheter 25 is protected from any accumulation of mucus. When the inner catheter 25 is extended from the outer sleeve 24, the domed end cap 44 contacts the underside of the swivelable cap 32 of the outer sleeve 24, pushing it to the open position 34 (shown by dotted lines) as the hinge 56 flexes. As the inner catheter 25 extends out of the outer sleeve 24, any remaining mucus which may be encountered is pushed aside or collected on the domed end cap 44 and not forced into the side port 45.

Although the preferred shape of the depositing end 39 of the inner catheter 25 has been fully described, alternate methods of construction are illustrated in FIGS. 11 & 12 with the interior passage 57 continuing straight and unobstructed, without the domed end cap, and exiting the end of the inner catheter 25. FIG. 11 incorporates side wall relief or opening means embodied by two reliefs 61, spaced at 180 degrees apart, at the end of the inner catheter 25. Thus, for example, even in the event of the depositing end 39 of the inner catheter 25 butting firmly against a wall of the uterus, the embryos may be discharged from the inner catheter 25 through the reliefs 61. In the most simplified form, the inner catheter 25 of FIG. 12 incorporates a blunt end opening 62. Although the benefits from the features of the previously described inner catheters are not available with a blunt opening 62, the combined use with the outer sleeve 24, as herein taught, offers protection from mucus while within the outer sleeve 24.

FIGS. 13 through 19 describe pictorially the steps involved in the use of the catheter system 20. With reference to FIG. 13, prior to the use of the catheter system

20, a sounding is performed to determine the depth of the uterus 21 and the distance D1 from the entrance 38 of the cervix 26 to the location within the uterus 21 where the embryos 22 are to be deposited for implanting. The depositing end 39 of the inner catheter 25 is inserted into the interior of the outer sleeve 24 at the manipulating end 40 and the movable stop 50 is adjusted to the proper position as shown in FIG. 13. "S" represents the depth of the uterus 21 as determined by the sounding. The desired depth at which the embryos are to be deposited is shown as D1. D2 is the distance that the insertable portion 29 of the outer sleeve 24 will insert into the cervix 26. D3 is the distance that the inner catheter 25 will be required to extend beyond the end of the outer sleeve 24 for implanting at the desired depth D1. D4 is the distance that the inner catheter 25 will be short of exiting from within the outer sleeve 24 when the implanting process is begun. The sum of distances D3 and D4 is E1, the extending distance, the amount the inner catheter 25 will extend for implanting. The extending distance E1 is equal to E2, the measurement at which the snug fitting movable stop 50 is to be positioned, the distance short of contacting the second flange 43 at the manipulating end 40 of the outer sleeve 24. As discussed with FIG. 8, markings 60 may be incorporated on inner sleeve 25 to provide dimensional aid in locating movable stop 50 at distance E2 from second flange 43.

After adjustment is completed, the inner catheter 25 (with the movable stop 50 being unmoved and remaining in place) is withdrawn from the outer sleeve 24. The interior of the inner catheter 25 is rinsed with a buffer solution by a tuberculin syringe (in a well known manner) and then loaded as illustrated in FIGS. 14A, 14B, and 14C and according to the following instructions. As shown in FIG. 14A, with a syringe 48 inserted into the receiver 47 at the manipulating end 46 of the inner catheter 25, draw buffer solution 63 into the side port 45 at the depositing end 39 to the marking 60 corresponding to about 0.2 milliliters. Draw in a small

amount of air, then load embryos 22 into side port 45 as in FIG. 14B. Draw in another small amount of air, then draw up about 0.005 milliliters of buffer solution 63. FIG. 14C shows inner catheter 25 appropriately loaded with buffer solution 63, two air spaces 64 and embryos 22, with markings 60 used to determine quantities.

Then, as shown in FIG. 15A, insert the inner catheter 25 into cylindrical hollow 28 at the manipulating end 40 of the outer sleeve 24 until the depositing end 39 of the inner catheter 25 is just short of contacting the swivelable cap 32 (or the less preferred alternate slits 53) of the outer sleeve 24 (as shown in FIG. 15B). In this position, the swivelable cap 32 remains in the closed position 33. Then, with the catheter system 20 now prepared for usage, insert the depositing end 31 of the insertable portion 29 of the outer sleeve 24 into the cervix 26 of the patient, as shown in FIG. 16A. Then (see FIG. 16B) insert the outer sleeve 24 through the cervix 26, until its limiting stop 37 of flange 36 contacts the cervix entrance 38.

Then, after the outer sleeve 24 is in position, advance the inner catheter 25 until the movable stop 50 contacts the second flange 43 of the outer sleeve 24. During this process, as shown in FIG. 17, the inner catheter 25 pushes aside the swivelable cap 32 (or through the less preferred slits 53) of the outer sleeve 24 to the open position 34. When advancement is completed, the depositing end 39 of the inner catheter 25 is properly positioned in the uterus 21 for implanting. Next, as shown in FIG. 18, using syringe 48 inserted into the receiver 47 of the inner catheter 25, slowly inject about 0.02 to 0.03 milliliters of the contents of the inner catheter 25 into the uterus 21. This injection transfers a small amount of buffer solution 63 along with the embryos 22 from the side port 45 into a desired location within the uterus 21 where the embryos 22 may attach the uterus wall 27. Then, after such implanting, the catheter system 20 is to remain unmoved for about one minute. Then, carefully withdraw the outer sleeve 24 and inner catheter 25

from the patient, and, as shown in FIG. 19, with a microscope 66, insure that embryos do not remain in the inner catheter 25.

Although applicant has described applicant's preferred embodiments of this invention, it will be understood that the broadest scope of this invention includes such modifications as diverse shapes and sizes and materials. Such scope is limited only by the below claims as read in connection with the above specification.

Further, many other advantages of applicant's invention will be apparent to those skilled in the art from the above descriptions and the below claims.

What is claimed is:

1. A catheter system for assisting implanting embryos in a uterus, comprising:

a. catheter sleeve means, having a sleeve distal end and a sleeve proximal end and having, between said sleeve distal end and said sleeve proximal end, a longitudinal cylindrical hollow having a central longitudinal axis, said catheter sleeve means being structured and arranged for containing an inner catheter in said cylindrical hollow, said catheter sleeve means comprising

i. end cap means, disposed along an intersection of said central axis at said sleeve distal end, for substantially enclosing said cylindrical hollow at said sleeve distal end to protect said cylindrical hollow from accumulating mucuslike material when said catheter sleeve means is inserted into a said uterus, said end cap means comprising

(1) end opening means, disposed along said intersection of said central axis at said sleeve distal end, for permitting passage of an inner catheter along said central axis from within said cylindrical hollow into a said uterus;

b. said catheter sleeve means being structured and arranged for insertion of said sleeve distal end into a said uterus for assistance in implanting embryos.

2. A catheter system according to Claim 1 wherein said end opening means of said sleeve distal end comprises swivel means constructed and arranged in such manner that said end cap means swivels outward when an inner catheter is pushed through said sleeve distal end.

3. A catheter system according to Claim 2 wherein said end cap means comprises an outwardly convex flexible end on said catheter sleeve means and said end cap opening means comprises a partial transverse cut separating, except for a remaining transverse hinge portion, said outwardly convex flexible end from said catheter sleeve means, whereby said end cap means is constructed and arranged to swivel outward when an inner catheter is pushed through said sleeve distal end.
4. A catheter system according to Claim 1, further comprising:
 - a. an inner catheter means, having a catheter distal end and a catheter proximal end, for transporting a said embryo through said cylindrical hollow of said outer sleeve means into access to said uterus and for depositing said embryo in said uterus.
5. A catheter system according to Claim 4 wherein said inner catheter means comprises indicia means for indicating longitudinal distance to assist in attaining a desired implanting location.
6. A catheter system according to Claim 4 wherein said catheter distal end comprises:
 - a. catheter distal opening means for depositing said embryo, said catheter distal opening means comprising a side port, adjacent said catheter distal end of said inner catheter means.
7. A catheter system according to Claim 4 wherein said catheter distal end comprises:
 - a. second end cap means at said catheter distal end for protecting said inner catheter means when said catheter distal end is pushed through said sleeve distal end; and
 - b. catheter distal opening means for depositing said embryo, said catheter distal opening means comprising a side port adjacent said second end cap means at said catheter distal end of said inner catheter means.

8. A catheter system according to Claim 7 wherein said catheter distal end further comprises:
 - a. strengthening means opposite said catheter distal opening means for strengthening said inner catheter means against breakage.
9. A catheter system according to Claim 7 wherein said end opening means at said sleeve distal end of said catheter sleeve means comprises swivel means constructed and arranged in such manner that said end cap means swivels outward when said catheter distal end is pushed through said sleeve distal end.
10. A catheter system according to Claim 9 wherein said catheter sleeve means further comprises first stop means for limiting insertion to a desired location when said catheter sleeve means is inserted into a said uterus.
11. A catheter system according to Claim 10 wherein said inner catheter means further comprises second stop means settable along said inner catheter means for limiting insertion to a desired implanting location when said inner catheter means is inserted into a said uterus.
12. A catheter system according to Claim 1 wherein said catheter sleeve means further comprises stop means for limiting insertion to a desired location when said catheter sleeve means is inserted into a said uterus.

13. A catheter system for implanting embryos in a uterus, comprising:
- a. a catheter outer sleeve having a longitudinal cylindrical hollow between a sleeve distal end and a sleeve proximal end, for providing safe catheter access to a said uterus by a catheter having a catheter distal end and a catheter proximal end;
 - b. said sleeve distal end comprising
 - i. an outwardly convex end cap, for protecting said cylindrical hollow from accumulating mucuslike material when said catheter outer sleeve is inserted into a said uterus, and
 - ii. an outwardly-swivelable connection between said end cap and said catheter outer sleeve, for permitting passage of a said catheter distal end from said cylindrical hollow into a said uterus when said catheter distal end is pushed against said end cap to swivel said end cap outwardly and move said catheter distal end through said sleeve distal end.
14. A catheter system according to Claim 13 further comprising:
- a. an inner catheter means, having a catheter distal end and a catheter proximal end, for transporting a said embryo through said cylindrical hollow of said outer sleeve into access to said uterus and for depositing said embryo in said uterus.
15. A catheter system according to Claim 14 wherein said catheter distal end comprises:
- a. an outwardly convex second end cap for protecting said inner catheter means when said catheter distal end is pushed through said sleeve distal end; and
 - b. a catheter distal opening for depositing a said embryo, said catheter distal opening comprising a side port adjacent said second end cap.

16. A catheter system according to Claim 15 further comprising:
- a. locating means for locating said catheter distal end in a said uterus, said locating means comprising
 - i. first stop means on said catheter outer sleeve for abutting a cervix entrance to said uterus, and
 - ii. second stop means settable along said inner catheter means for limiting insertion of said catheter distal end of said inner catheter means to a desired implanting location when said inner catheter means is inserted into a said uterus.
17. A catheter system for implanting embryos in a uterus, comprising, in combination, the steps of:
- a. providing a catheter outer sleeve having a longitudinal cylindrical hollow between a sleeve proximal end and a sleeve distal end having an outwardly convex end cap and an outwardly-swivelable connection between said end cap and said catheter outer sleeve;
 - b. providing a catheter having a catheter proximal end and a catheter distal end having an opening for transmission of a said embryo, said catheter being sized for moving through said longitudinal cylindrical hollow;
 - c. loading at least one said embryo into said catheter distal end;
 - d. placing said catheter into said sleeve proximal end of said catheter outer sleeve and moving said catheter forward until said catheter distal end is approaching said sleeve distal end;
 - e. introducing said sleeve proximal end into a said uterus to a desired stop location;
 - f. further moving said catheter forward into said end cap of said catheter outer sleeve, outwardly swiveling said end cap, and further moving said catheter distal end forward into said uterus to a desired implanting location; and
 - g. flushing said embryo out of said catheter distal end.

18. A catheter system according to Claim 17 wherein said catheter distal end of said catheter comprises:
 - a. a second end cap for protecting said catheter when said catheter distal end is pushed through said sleeve distal end; and
 - b. a catheter distal opening for depositing a said embryo, said catheter distal opening comprising a side port adjacent said second end cap.
19. A catheter system according to Claim 18 wherein:
 - a. said catheter outer sleeve further comprises first stop means located along said catheter outer sleeve for limiting insertion to said desired stop location when said catheter outer sleeve is inserted into a said uterus; and
 - b. said catheter further comprises second stop means settable along said catheter for limiting insertion to said desired implanting location when said inner catheter means is inserted into a said uterus.

20. A catheter system according to Claim 17 wherein said outwardly-swivelable connection between said end cap and said outer sleeve is made by a method comprising the steps of:

- a. providing an outwardly convex end portion at said sleeve distal end integral with said catheter outer sleeve; and
- b. cutting to partially sever said end portion from said catheter outer sleeve transversely just beneath said end portion around at least about 300 degrees of a circumference around said convex end portion;
- c. whereby an unsevered part of said end portion provides a hinge means comprising said outwardly-swivelable connection.

21. A catheter system for assisting implanting embryos in a uterus, comprising:

- a. catheter sleeve means, having a sleeve distal end and a sleeve proximal end and having a longitudinal cylindrical hollow between said sleeve distal end and said sleeve proximal end, for containing an inner catheter in said cylindrical hollow, said catheter sleeve means comprising
 - i. end cap means at said sleeve distal end for substantially enclosing said cylindrical hollow at said sleeve distal end to protect said cylindrical hollow from accumulating mucuslike material when said catheter sleeve means is inserted into a said uterus, and
 - ii. end opening means at said sleeve distal end for permitting passage of an inner catheter from within said cylindrical hollow into a said uterus;
- b. wherein said end opening means of said sleeve distal end comprises swivel means constructed and arranged in such manner that said end cap means swivels outward when an inner catheter is pushed through said sleeve distal end.

22. A catheter system according to Claim 21 wherein said end cap means comprises an outwardly convex flexible end on said catheter sleeve means and said end cap opening means comprises a partial transverse cut separating, except for a remaining transverse hinge portion, said outwardly convex flexible end from said catheter sleeve means, whereby said end cap means is constructed and arranged to swivel outward when an inner catheter is pushed through said sleeve distal end.

23. A catheter system for assisting implanting embryos in a uterus, comprising:

a. catheter sleeve means, having a sleeve distal end and a sleeve proximal end and having a longitudinal cylindrical hollow between said sleeve distal end and said sleeve proximal end, for containing an inner catheter in said cylindrical hollow, said catheter sleeve means comprising

i. end cap means at said sleeve distal end for substantially enclosing said cylindrical hollow at said sleeve distal end to protect said cylindrical hollow from accumulating mucuslike material when said catheter sleeve means is inserted into a said uterus, and

ii. end opening means at said sleeve distal end for permitting passage of an inner catheter from within said cylindrical hollow into a said uterus;

b. an inner catheter means, having a catheter distal end and a catheter proximal end, for transporting a said embryo through said cylindrical hollow of said outer sleeve means into access to said uterus and for depositing said embryo in said uterus;

c. wherein said catheter distal end comprises:

i. second end cap means at said catheter distal end for protecting said inner catheter means when said catheter distal end is pushed through said sleeve distal end; and

ii. catheter distal opening means for depositing said embryo, said catheter distal opening means comprising a side port adjacent said second cap means at said catheter distal end of said inner catheter means; and

d. wherein said end opening means at said sleeve distal end of said catheter sleeve means comprises swivel means constructed and arranged in such manner that said end cap means swivels outward when said catheter distal end is pushed through said sleeve distal end.

24. A catheter system according to Claim 23 wherein said catheter sleeve means further comprises first stop means for limiting insertion to a desired location when said catheter sleeve means is inserted into a said uterus.

25. A catheter system according to Claim 24 wherein said inner catheter means further comprises second stop means settable along said inner catheter means for limiting insertion to a desired implanting location when said inner catheter means is inserted into a said uterus.

26. A catheter system according to Claim 1 wherein said end opening means is a slit, normally closed but openable for permitting passage of a said inner catheter pushed along said central axis from within said cylindrical hollow into a said uterus.

27. A catheter system according to Claim 1 wherein said end opening means of said sleeve distal end is a cross-cut slit, normally closed but openable for permitting passage of a said inner catheter pushed along said central axis from within said cylindrical hollow into a said uterus.

1/5

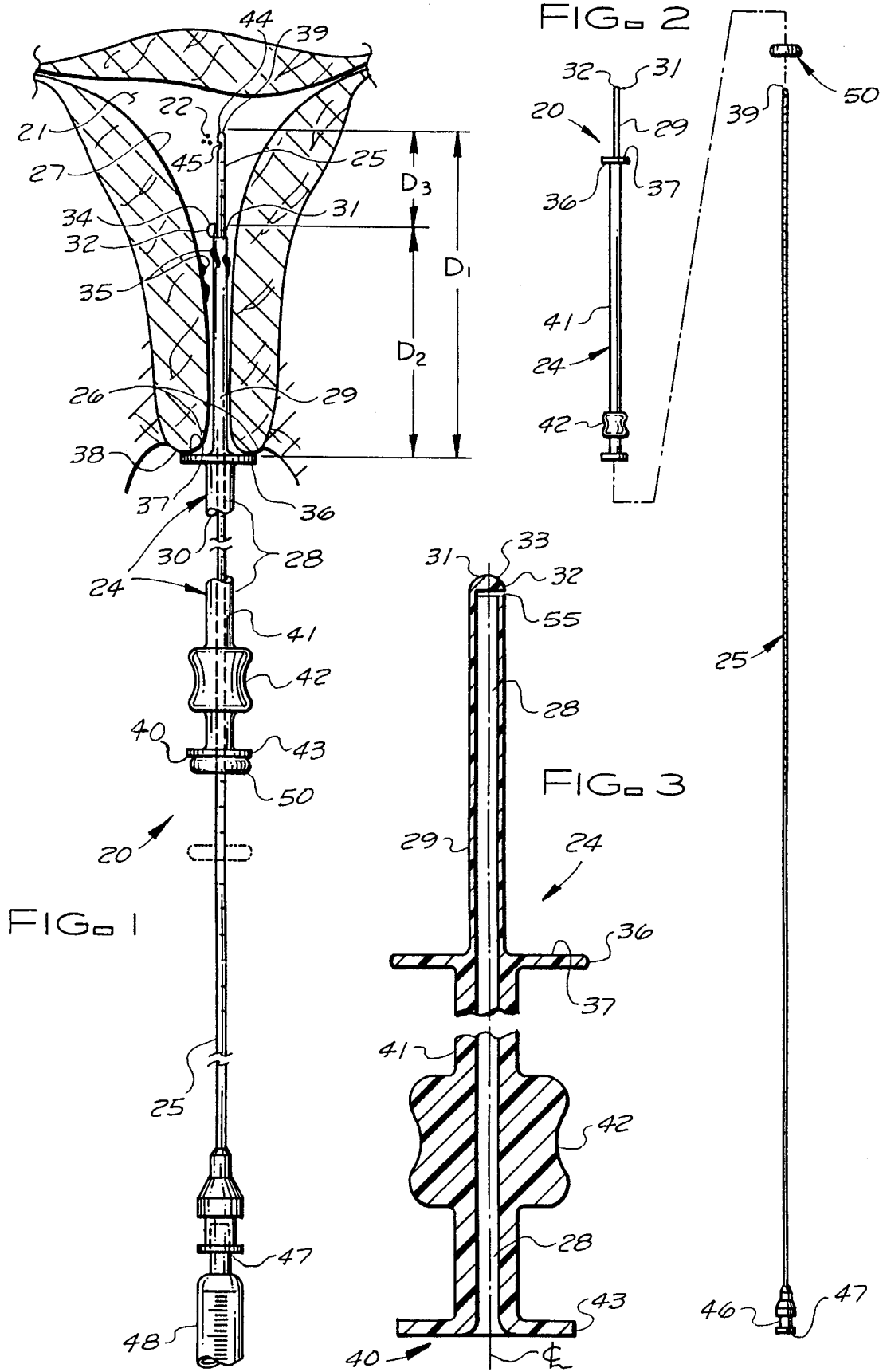

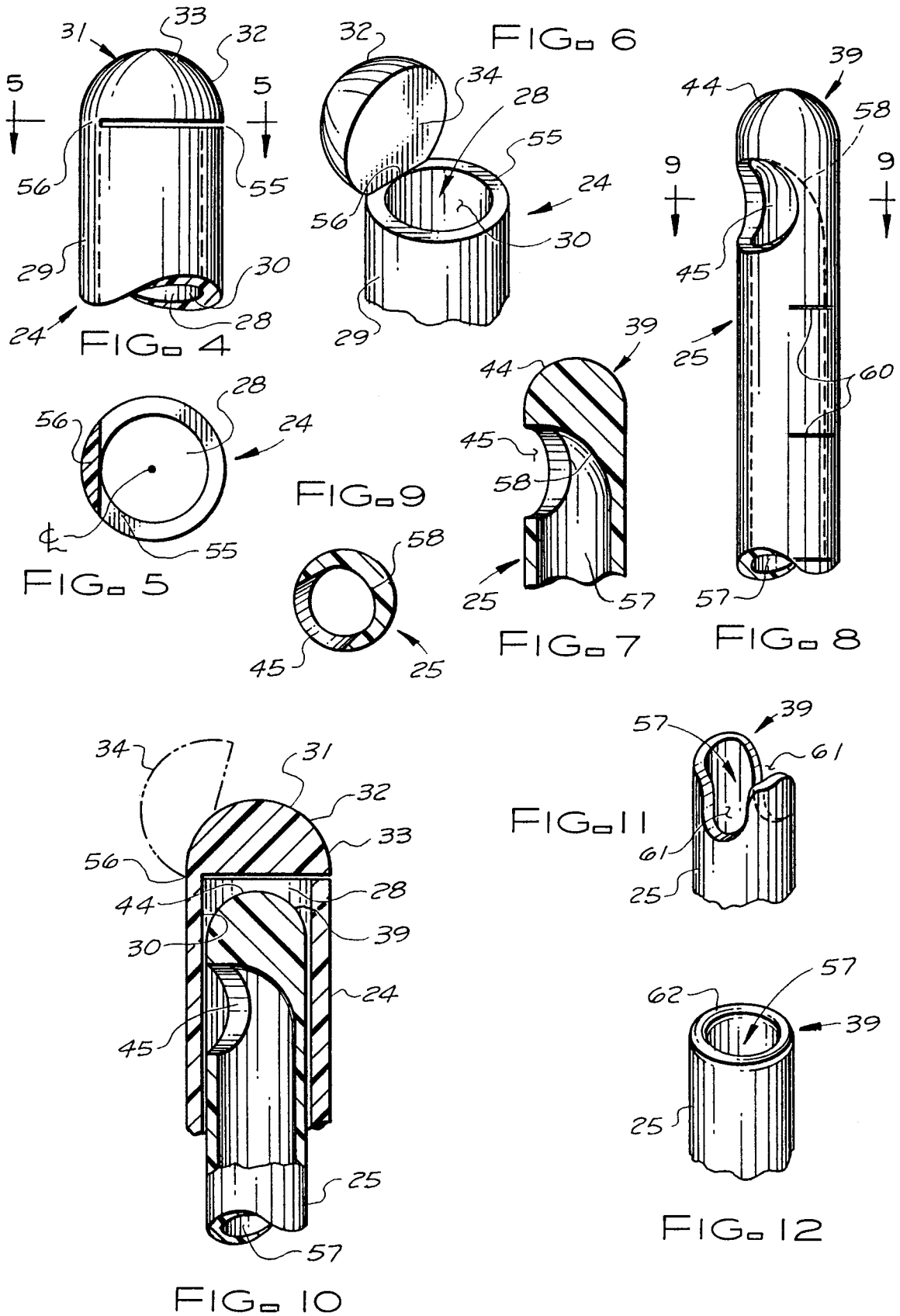

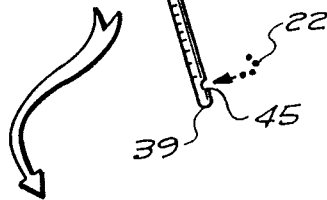
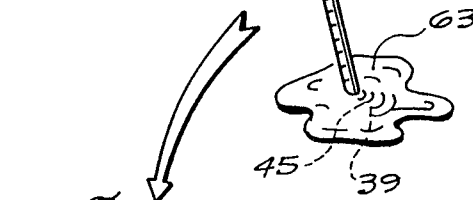
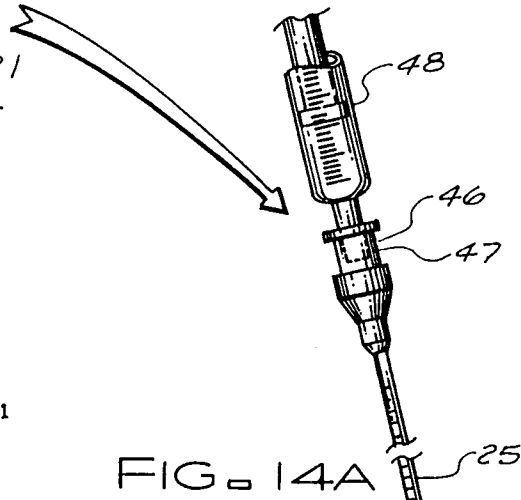
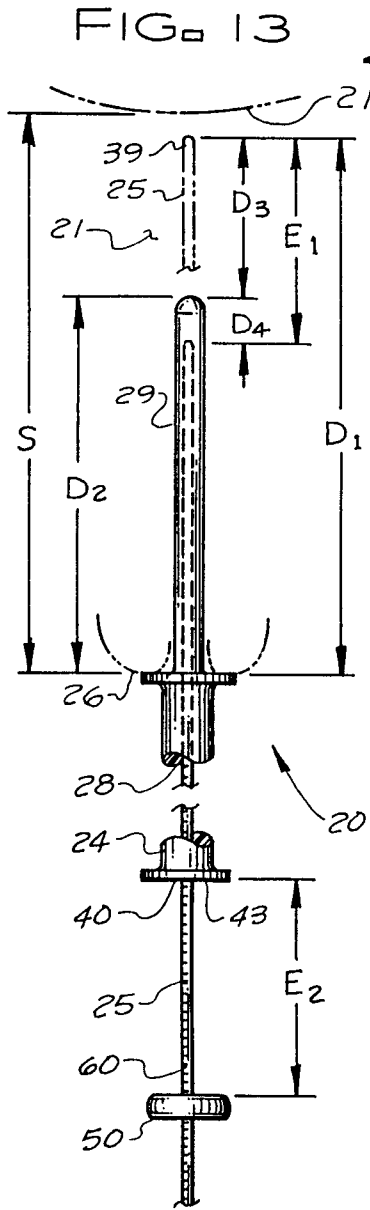

FIG. 14C

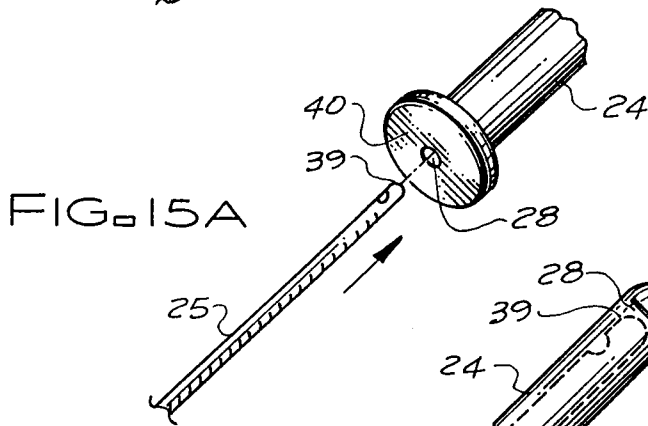
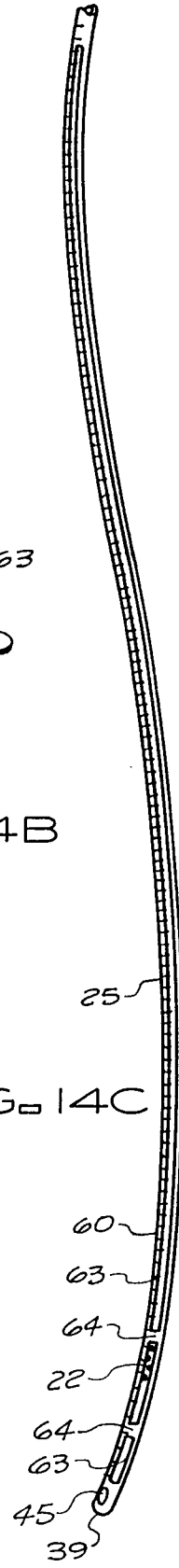
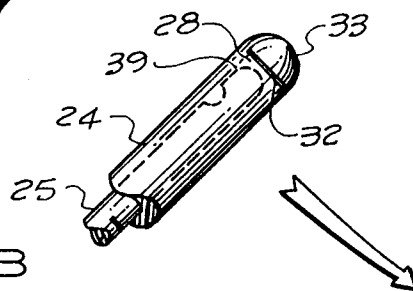
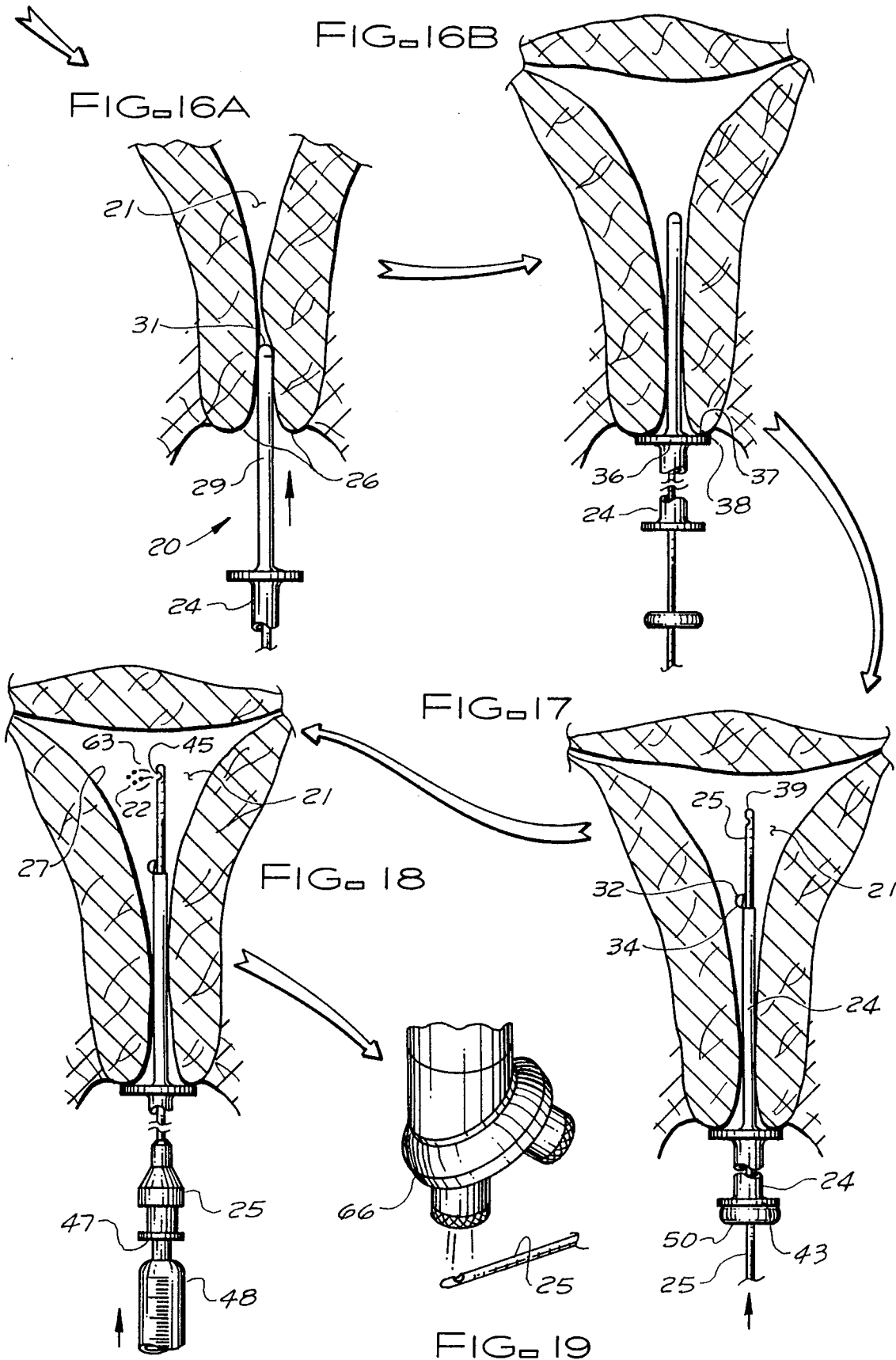
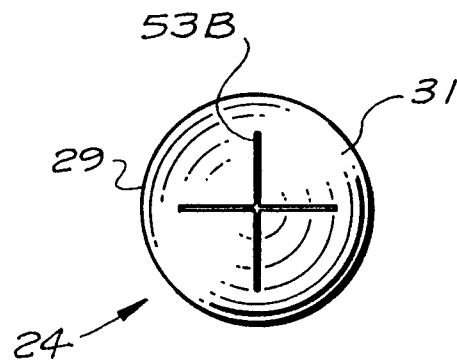
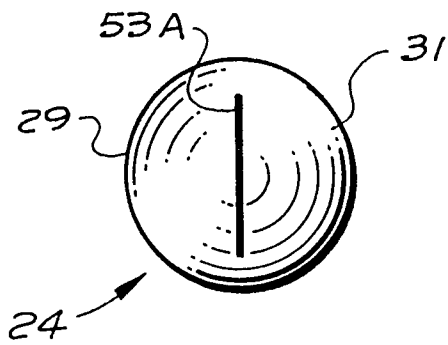
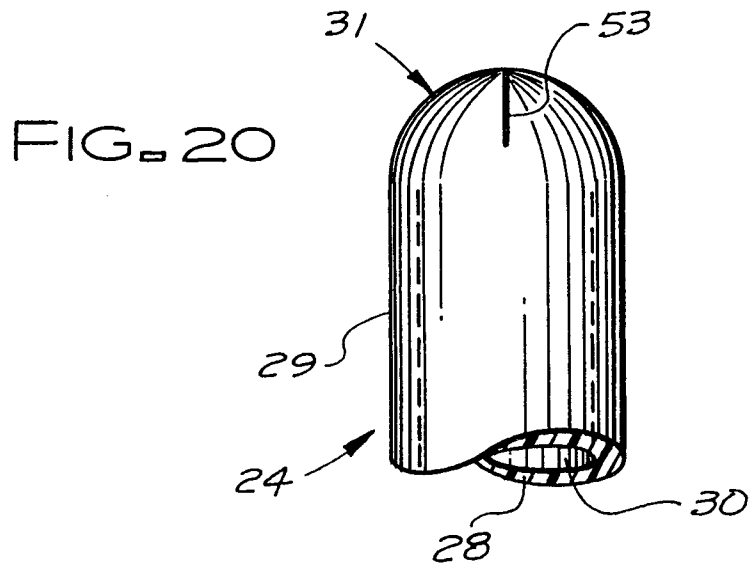

FIG. 15B







INTERNATIONAL SEARCH REPORT

International application No.
PCT/US98/01660**A. CLASSIFICATION OF SUBJECT MATTER**

IPC(6) :A61M 25/00

US CL :604/264

According to International Patent Classification (IPC) or to both national classification and IPC

B. FIELDS SEARCHED

Minimum documentation searched (classification system followed by classification symbols)

U.S. : 600/33-35; 604/27, 28, 48, 53-55, 164, 174, 264, 278, 280; 606/119, 193

Documentation searched other than minimum documentation to the extent that such documents are included in the fields searched

Electronic data base consulted during the international search (name of data base and, where practicable, search terms used)

C. DOCUMENTS CONSIDERED TO BE RELEVANT

Category*	Citation of document, with indication, where appropriate, of the relevant passages	Relevant to claim No.
A	US 5,083,572 A (POKORNY) 28 January 1992, specification.	1, 4
A	US 4,863,423 A (WALLACE) 05 September 1989, specification.	6-8

 Further documents are listed in the continuation of Box C.
 See patent family annex.

* Special categories of cited documents:	*T* later document published after the international filing date or priority date and not in conflict with the application but cited to understand the principle or theory underlying the invention
A document defining the general state of the art which is not considered to be of particular relevance	*X* document of particular relevance; the claimed invention cannot be considered novel or cannot be considered to involve an inventive step when the document is taken alone
E earlier document published on or after the international filing date	*Y* document of particular relevance; the claimed invention cannot be considered to involve an inventive step when the document is combined with one or more other such documents, such combination being obvious to a person skilled in the art
L document which may throw doubts on priority claim(s) or which is cited to establish the publication date of another citation or other special reason (as specified)	*Z* document member of the same patent family
O document referring to an oral disclosure, use, exhibition or other means	
P document published prior to the international filing date but later than the priority date claimed	

Date of the actual completion of the international search

13 MARCH 1998

Date of mailing of the international search report

08 APR 1998

Name and mailing address of the ISA/US
Commissioner of Patents and Trademarks
Box PCT
Washington, D.C. 20231

Facsimile No. (703) 305-3230

Authorized officer

 CRIS L. RODRIGUEZ

Telephone No. (703) 308-2194