

(19) World Intellectual Property Organization
International Bureau



(43) International Publication Date
19 October 2006 (19.10.2006)

PCT

(10) International Publication Number
WO 2006/110438 A2

- (51) International Patent Classification:
B62B 1/00 (2006.01)
- (21) International Application Number:
PCT/US2006/012764
- (22) International Filing Date: 5 April 2006 (05.04.2006)
- (25) Filing Language: English
- (26) Publication Language: English
- (30) Priority Data:

60/669,540	7 April 2005 (07.04.2005)	US
60/713,286	31 August 2005 (31.08.2005)	US
11/278,657	4 April 2006 (04.04.2006)	US

AT, AU, AZ, BA, BB, BG, BR, BW, BY, BZ, CA, CH, CN, CO, CR, CU, CZ, DE, DK, DM, DZ, EC, EE, EG, ES, FI, GB, GD, GE, GH, GM, HR, HU, ID, IL, IN, IS, JP, KE, KG, KM, KN, KP, KR, KZ, LC, LK, LR, LS, LT, LU, LV, LY, MA, MD, MG, MK, MN, MW, MX, MZ, NA, NG, NI, NO, NZ, OM, PG, PH, PL, PT, RO, RU, SC, SD, SE, SG, SK, SL, SM, SY, TJ, TM, TN, TR, TT, TZ, UA, UG, US, UZ, VC, VN, YU, ZA, ZM, ZW.

(84) Designated States (unless otherwise indicated, for every kind of regional protection available): ARIPO (BW, GH, GM, KE, LS, MW, MZ, NA, SD, SL, SZ, TZ, UG, ZM, ZW), Eurasian (AM, AZ, BY, KG, KZ, MD, RU, TJ, TM), European (AT, BE, BG, CH, CY, CZ, DE, DK, EE, ES, FI, FR, GB, GR, HU, IE, IS, IT, LT, LU, LV, MC, NL, PL, PT, RO, SE, SI, SK, TR), OAPI (BF, BJ, CF, CG, CI, CM, GA, GN, GQ, GW, ML, MR, NE, SN, TD, TG).

- (71) Applicant and
- (72) Inventor: MONAGHAN, Michael, J. [US/US]; 4461 N. Launfal Ave, Phoenix, Arizona 85018 (US).
- (74) Agent: STONEMAN, Martin, L.; STONEMAN LAW OFFICES, LTD, 3113 North 3rd Street, Phoenix, Arizona 85012-2601 (US).

Declaration under Rule 4.17:
— of inventorship (Rule 4.17(iv))

Published:
— without international search report and to be republished upon receipt of that report

- (81) Designated States (unless otherwise indicated, for every kind of national protection available): AE, AG, AL, AM,

For two-letter codes and other abbreviations, refer to the "Guidance Notes on Codes and Abbreviations" appearing at the beginning of each regular issue of the PCT Gazette.

(54) Title: INFANT ACTIVITY SYSTEMS

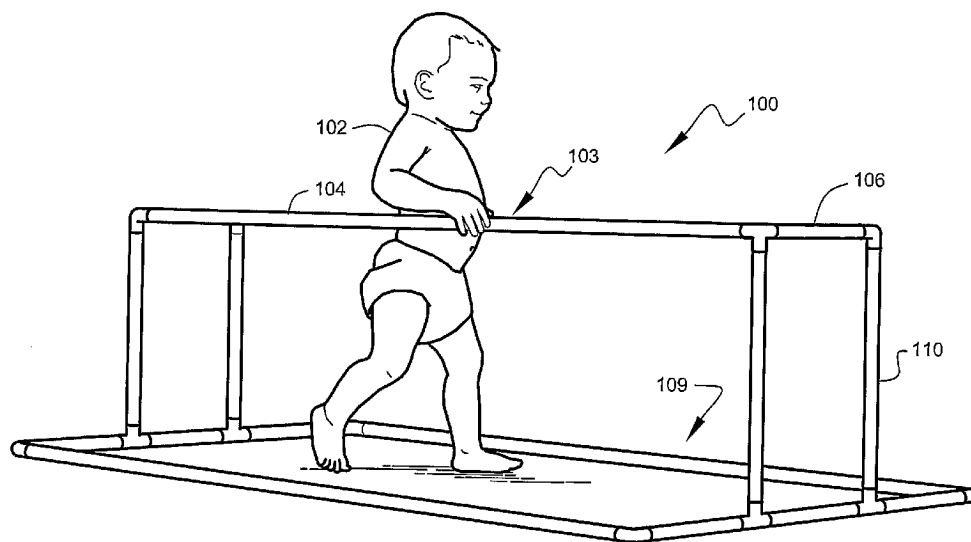

(57) Abstract: A safe and fun exercise and walking-training apparatus and method that is ideal for infants in the approximate age range of 10 months to 18 months is disclosed. The apparatus is lightweight, very sturdy, very simple, consisting of only six unique elements, and may be assembled and disassembled by hand without tools. A system of attachable play features is also disclosed.

WO 2006/110438 A2

INFANT ACTIVITY SYSTEMS**BACKGROUND**

This invention relates to providing a system for an improved walking training system for infants. More particularly, this invention relates to providing a system, for infant exercise and entertainment, which provides opportunities for walking training of infants learning to walk.

Frequently, children learn to walk by "furniture surfing" (e.g., infants who are just starting to stand, holding onto sofas and coffee tables as they navigate their way around a living room). At least in part, this may be due to the lack of an alternative method. Obviously, "furniture surfing" represents a risk to the infant, e.g., in the event the infant should fall against a sharp corner or edge.

A primary alternative to "furniture surfing" is "parent surfing", which involves the active participation of the adult in holding the infant's hands while the infant attempts to walk. This method is often short-lived due to adult fatigue.

Today, there are few readily available alternatives which provide the functional combination of walking training, exercise and entertainment. Generally, the currently readily available alternatives fail to provide at least one of the desired functions and often have significant safety limitations, even with parental supervision.

Heretofore, other solutions have tended to be heavy, expensive, complicated, difficult to set up, difficult to manufacture, and costly to manufacture. Additionally, safety-related features have been limited.

Therefore, a need exists for a system which is safe, inexpensive and easily manufactured, and which provides infant walking training in combination with other functions.

OBJECTS AND FEATURES OF THE INVENTION

A primary object and feature of the present invention is to provide a system for infant walking training.

It is a further primary object and feature of the present invention to provide such a system for promoting infant exercise.

It is another primary object and feature of the present invention to provide such a system for promoting infant entertainment.

It is an additional primary object and feature of the present invention to provide such a system for promoting infant walking training which is safe for infants.

It is another primary object and feature of the present invention to provide such a system adaptable to the training of older children and patient physical therapy.

It is yet another primary object and feature of the present invention to provide such a system which is inexpensive.

It is still a further primary object and feature of the present invention to provide such a system that is easily assembled, disassembled, transported and stored.

Another primary object and feature of the present invention is to provide such a system that is lightweight.

It is another primary object and feature of the present invention to provide such a system that is easily and inexpensively manufactured.

Other objects and features of this invention will become apparent with reference to the following descriptions.

SUMMARY OF THE INVENTION

In accordance with a preferred embodiment hereof, this invention provides an infant activity system, relating to providing unrestricted learning-to-walk oriented play activities to at least one infant, comprising: upper polygonal peripheral graspable bar means for grasping by the at least one infant; lower polygonal peripheral support means for supporting such upper polygonal peripheral graspable bar means in at least one fixed elevation position; and geometry means for permitting essentially free movement by the at least one infant throughout such infant activity system. Moreover, it provides such an infant activity system, wherein such geometry means comprises tilt-prevention means for essentially preventing tilting of such infant activity system when the at least one infant applies forces to such upper polygonal peripheral graspable bar means. Additionally, it provides such an infant activity system, wherein such lower polygonal peripheral support means comprises lower polygonal peripheral base means surrounding at least one base area for providing at least one lower polygonal peripheral base for such infant activity system. Also, it provides such an infant activity system, wherein such geometry means comprises tilt-prevention means for essentially preventing tilting of such infant activity system when the at least one infant applies forces to such upper polygonal peripheral graspable bar means. In addition, it provides such an infant activity system, wherein such tilt-prevention means comprises geometric retention means for geometrically retaining at least one center of gravity of such infant activity system within such at least one base area when the at least one infant applies forces to such upper polygonal peripheral graspable bar means. And, it provides such an infant activity system, further comprising attacher means for attaching such upper polygonal peripheral graspable bar means to such lower polygonal peripheral support means.

In accordance with another preferred embodiment hereof, this invention provides an infant activity system relating to providing unrestricted activities to at least one infant comprising in combination: at least one upper polygonal peripheral graspable bar adapted to be grasped by the at least one infant; at least one lower polygonal peripheral support adapted to support such at least one upper polygonal peripheral graspable bar in at least one fixed elevation position; and at least one geometric arrangement adapted to allow essentially free movement by the at least one infant throughout such infant activity system. Further, it provides such an infant activity system, wherein such at least one geometric arrangement comprises at least one tilt-prevention arrangement adapted to essentially prevent tilting of

such infant activity system when the at least one infant applies forces to such at least one upper polygonal peripheral graspable bar. Even further, it provides such an infant activity system, wherein such lower polygonal peripheral support comprises: at least one lower polygonal peripheral base surrounding at least one base area; wherein at least one geometric relationship between such at least one lower polygonal peripheral base and such at least one upper polygonal peripheral graspable bar allows retention of at least one center of gravity of such infant activity system within such at least one base area when the at least one infant applies forces to such upper polygonal peripheral graspable bar; and at least one attacher adapted to attach such at least one lower polygonal peripheral base to such at least one upper polygonal peripheral graspable bar. Moreover, it provides such an infant activity system, wherein such at least one lower polygonal peripheral base comprises: at least six end bars, each of essentially equal length; at least two side bars, each of essentially equal length; at least four 90-degree elbow bar connectors; and at least four tee bar connectors.

Additionally, it provides such an infant activity system, wherein such at least one attacher comprises at least four attacher bars, each of essentially equal length. Also, it provides such an infant activity system, wherein such at least one upper polygonal peripheral graspable bar comprises: at least two end bars, each of essentially equal length; at least two side bars, each of essentially equal length; and at least four three-way elbow bar connectors.

In accordance with another preferred embodiment hereof, this invention provides a kit system for assembling at least one infant activity system relating to providing unrestricted learning-to-walk activities to at least one infant comprising: at least one side bar set; at least one attacher bar set; at least one end bar set; at least one connector set; at least one container; at least one assembly instruction sheet; and at least one indicia; wherein such at least one side bar set, such at least one attacher bar set, such at least one end bar set, and such at least one connector set are assembled to provide such infant activity system. In addition, it provides such a kit system, wherein such at least one side bar set comprises at least four side bars, each of essentially equal length. And, it provides such a kit system, wherein such at least four side bars comprise schedule 40 polymerized vinyl chloride pipe. Further, it provides such a kit system, wherein such at least four side bars comprise color coding. Even further, it provides such a kit system, wherein such at least one end bar set comprises at least eight end bars, each of essentially equal length. Moreover, it provides such a kit system, wherein such at least eight end bars comprise schedule 40 polymerized vinyl chloride pipe. Additionally, it provides such a kit system, wherein such at least eight end bars comprise color coding. Also, it provides such a kit system, wherein such at least one connector set comprises: at least four three-way elbow bar connectors; at least four 90-degree elbow bar connectors; and at least four tee bar connectors. In addition, it provides such a kit system, wherein: such at least four three-way elbow bar connectors comprise schedule 40 polymerized vinyl chloride; such at least four 90-degree elbow bar connectors comprise

schedule 40 polymerized vinyl chloride; and such at least four tee bar connectors comprise schedule 40 polymerized vinyl chloride. And, it provides such a kit system, wherein: such at least four three-way elbow bar connectors comprise color coding; such at least four 90-degree elbow bar connectors comprise color coding; and such at least four tee bar connectors comprise at least one color coded-element. Further, it provides such a kit system, wherein such at least one attacher bar set comprises at least four attacher bars, each of essentially equal length. Even further, it provides such a kit system, wherein such at least four attacher bars comprise schedule 40 polymerized vinyl chloride pipe. Even further, it provides such a kit system, wherein such at least four attacher bars comprise color coding. Even further, it provides such a kit system, wherein such at least one container permits easy storage of such at least one infant activity system after disassembly.

Furthermore, it provides such a kit system, further comprising at least one removably attachable play feature adapted to removably attach to such at least one infant activity system. In addition, it provides such a kit system, wherein said at least one removably attachable play feature comprises at least one sports related function. Furthermore, it provides such a kit system, wherein said at least one removably attachable play feature comprises at least one basketball hoop. And, it provides such a kit system, wherein said at least one removably attachable play feature comprises at least one soccer net. Furthermore, it provides such a kit system, wherein said at least one removably attachable play feature comprises: at least one soft toy; wherein said at least one soft toy comprises at least one removable attacher adapted to removably attach said at least one soft toy to said infant activity system. Furthermore, it provides such a kit system, wherein said at least one removably attachable play feature comprises at least one cover adapted to cover at least one portion of said infant activity system.

In accordance with another preferred embodiment hereof, this invention provides an infant activity system assembly method for at least one infant activity system, relating to providing unrestricted learning-to-walk oriented play activities to at least one infant, comprising upper polygonal peripheral graspable bar means for providing at least one polygonal peripheral graspable bar for grasping by such at least one infant; lower polygonal peripheral support means for supporting such upper polygonal peripheral graspable bar means in at least one fixed elevation position; and geometry means for permitting essentially free movement by such at least one infant throughout such infant activity system, comprising the steps of: providing at least one set of modular components; wherein such at least one set of modular components comprises at least one set of bars having essentially the same outside diameter, and at least one set of connectors having essentially the same inside diameter; and assembling such at least one set of bars and such at least one set of connectors without tools to produce such at least one infant activity system. Even further, it provides such an infant activity system assembly method, wherein such at least one set of bars comprises: at least eight end

bars, each of essentially equal length; at least four side bars, each of essentially equal length; and at least four attacher bars. Even further, it provides such an infant activity system assembly method, wherein such at least one set of connectors comprises: at least four three-way elbow bar connectors; at least four 90-degree elbow bar connectors; and at least four tee bar connectors.

BRIEF DESCRIPTION OF THE DRAWINGS

FIG. 1 shows a perspective view of an infant activity system according to a preferred embodiment of the present invention and illustrating an infant using such system.

FIG. 2 shows a perspective view of the infant activity system according to the preferred embodiment of FIG. 1.

FIG. 3 shows the section 3-3 of FIG. 2 illustrating a preferred component fit method for the infant activity system according to the preferred embodiment of FIG. 2.

FIG. 4 shows a top elevational view of the infant activity system according to the preferred embodiment of FIG. 2.

FIG. 5 shows an end elevational view of the infant activity system according to the preferred embodiment of FIG. 2.

FIG. 6 shows a bottom elevational view of the infant activity system according to the preferred embodiment of FIG. 2.

FIG. 7 shows a side elevational view of the infant activity system according to the preferred embodiment of FIG. 2.

FIG. 8 shows a preferred infant activity system kit, illustrating the primary components of the kit preferably used to make up the infant activity system according to the preferred embodiment of FIG. 2.

FIG. 9 shows a perspective view of a side bar extender set of the infant activity system kit of FIG. 8.

FIG. 10 shows an exploded perspective view of the side bar extender set of FIG. 9, including assembled components of the infant activity system.

FIG. 11 shows a perspective view of an attachable play feature of the infant activity system kit of FIG. 8.

FIG. 12 shows a perspective view of the attachable play feature of FIG. 10, removably mounted to the infant activity system.

FIG. 13 shows the sectional view 13-13 of FIG. 12.

FIG. 14 shows a perspective view of another attachable play feature of the infant activity system kit of FIG. 8.

FIG. 15 shows a perspective view of another attachable play feature of the infant activity system kit of FIG. 8.

FIG. 16 shows a perspective view of another attachable play feature of the infant activity system kit of FIG. 8.

FIG. 17 shows a perspective view of a length adjustable attacher bar according to an alternate embodiment of the present invention.

DETAILED DESCRIPTION OF THE BEST MODES

AND PREFERRED EMBODIMENTS OF THE INVENTION

FIG. 1 shows a perspective view illustrating an infant activity system 100 according to a preferred embodiment of the present invention.

As shown, the infant activity system 100 comprises a group of bars and connectors preferably configured to provide a stable and safe system on which children can play while learning to walk. Preferably, the infant activity system 100 is configured to allow the infant to move in all directions around, under and through the infant activity system 100 essentially without limitation to promote interest and continuous usage for more than a few brief moments. Preferably, the infant activity system 100 is configured to allow a parent to assemble or disassemble system 100 without the use of tools because all connectors and bars are preferably friction-fittable without the use of fasteners. Preferably, the infant activity system 100 is configured to fit about 80 to about 90 percent of children approximately ten to eighteen months of age. Larger preferred embodiments of the present invention are suited to the training of physically challenged individuals and in patient physical therapy.

Preferably, as illustrated by FIG. 1 the infant 102 may walk or stand within the upper polygonal peripheral graspable bar 103 of the infant activity system 100 according to a preferred embodiment of the present invention. Because all sides of the infant activity system 100 are open, the infant 102 preferably may stand or walk on the outside of the upper polygonal peripheral graspable bar 103 (at least herein embodying upper polygonal peripheral graspable bar means for grasping by the at least one infant). Additionally, the infant 102 may also preferably use any attacher bar 110, the upper end bar 106, or the upper side bar 104 to pull itself up to a standing position because of the stability of the infant activity system 100 preferably provided by the geometric relationship of the upper polygonal peripheral graspable bar 103 and the lower polygonal peripheral support 109 (at least herein embodying lower polygonal peripheral support means for supporting said upper polygonal peripheral graspable bar means in at least one fixed elevation position). Preferably, as shown, the lower polygonal peripheral support 109 is at least three times the width of the upper polygonal peripheral graspable bar 103 and is preferably attached to the outer perimeter of the lower polygonal peripheral support 109 (as shown and described in FIG. 2 e.g., lower end bars 114 are cumulatively at least three times longer than upper end bar 106) (at least herein embodying attacher means for attaching said upper polygonal peripheral graspable bar means to said lower polygonal peripheral support means). According to a preferred embodiment of the present invention, these preferred geometric arrangements allow retention of the center of gravity of the infant activity system 100 within the area circumscribed by the lower polygonal

peripheral support 109 when an infant 102 applies forces to the upper polygonal peripheral graspable bar 103 (at least herein embodying geometry means for permitting essentially free movement by the at least one infant throughout said infant activity system; at least herein embodying wherein said geometry means comprises tilt-prevention means for essentially preventing tilting of said infant activity system when the at least one infant applies forces to said upper polygonal peripheral graspable bar means; at least herein embodying wherein said lower polygonal peripheral support means comprises lower polygonal peripheral base means surrounding at least one base area for providing at least one lower polygonal peripheral base for said infant activity system; at least herein embodying wherein said geometry means comprises tilt-prevention means for essentially preventing tilting of said infant activity system when the at least one infant applies forces to said upper polygonal peripheral graspable bar means; at least herein embodying wherein said tilt-prevention means comprises geometric retention means for geometrically retaining at least one center of gravity of said infant activity system within such at least one base area when the at least one infant applies forces to said upper polygonal peripheral graspable bar means).

FIG. 2 shows a perspective view of the infant activity system according to a preferred embodiment of the present invention. Preferably, the infant activity system 100 comprises at least one upper polygonal peripheral graspable bar 103 adapted to provide a graspable bar for grasping by an infant 102, as shown (at least herein embodying at least one upper polygonal peripheral graspable bar adapted to be grasped by the at least one infant). Preferably, the upper polygonal peripheral graspable bar 103 is comprised of two upper side bars 104, two upper end bars 106 and four three-way elbow bar connectors 108, as shown (at least herein embodying at least two end bars, each of essentially equal length; at least herein embodying at least two side bars, each of essentially equal length; at least herein embodying at least four three-way elbow bar connectors). Further, a lower polygonal peripheral support 109 is adapted preferably to support such at least one upper polygonal peripheral graspable bar 103 at a fixed height and in a fixed position, as shown (at least herein embodying at least one lower polygonal peripheral support adapted to support said at least one upper polygonal peripheral graspable bar in at least one fixed elevation position).

According to a preferred embodiment of the present invention, the geometric arrangement of the upper polygonal peripheral graspable bar 103, the attacher bars 110 and the lower polygonal peripheral support 109 preferably allows the infant 102 essentially movement around and through the infant activity system 100 (at least herein embodying at least one geometric arrangement adapted to permit essentially free movement by the at least one infant throughout said infant activity system).

Preferably, as shown, the lower polygonal peripheral support 109 is at least three times the width of the upper polygonal peripheral graspable bar 103 and is preferably attached to the outer perimeter of the lower polygonal peripheral support 109 because preferably the

lower end bars **114** are cumulatively at least three times longer than the upper end bars **106** (at least herein embodying wherein said at least one geometric arrangement comprises at least one tilt-prevention arrangement adapted to essentially prevent tilting of said infant activity system when the at least one infant applies forces to said at least one upper polygonal peripheral graspable bar; at least herein embodying at least one lower polygonal peripheral base surrounding at least one base area; at least herein embodying wherein at least one geometric relationship between said at least one lower polygonal peripheral base and said at least one upper polygonal peripheral graspable bar permits retention of at least one center of gravity of said infant activity system within such at least one base area when the at least one infant applies forces to said upper polygonal peripheral graspable bar; at least herein embodying at least one attacher adapted to attach said at least one lower polygonal peripheral base to said at least one upper polygonal peripheral graspable bar).

Preferably, as shown, the lower polygonal peripheral support **109** comprises at least one lower polygonal peripheral base **111** and four attacher bars **110** of essentially equal length (at least herein embodying wherein said at least one attacher comprises at least four attacher bars, each of essentially equal length). Preferably, the polygonal peripheral base **111** comprises at least six lower end bars **114**, at least two lower side bars **118**, at least four 90-degree elbow bar connectors **116** and at least four tee (T-shaped, herein sometimes "tee" or "T") bar connectors **112**, as shown (at least herein embodying at least six end bars, each of essentially equal length; at least herein embodying at least two side bars, each of essentially equal length; at least herein embodying at least four 90-degree elbow bar connectors; at least herein embodying at least four tee bar connectors).

Preferably, all bars (including upper side bar **104**, upper end bar **106**, attacher bar **110**, lower end bar **114**, and lower side bar **118**) comprise nominal one-inch outside diameter industry-standard plastic piping, preferably industry-standard polymerized vinyl chloride solid wall pipe, preferably industry-standard schedule 40 polymerized vinyl chloride solid wall pipe, which piping is well known in the plumbing industry and readily available commercially (at least herein embodying wherein said at least four side bars comprise schedule 40 polymerized vinyl chloride; at least herein embodying wherein said at least eight end bars comprise schedule 40 polymerized vinyl chloride pipe; at least herein embodying wherein said at least four attacher bars comprise schedule 40 polymerized vinyl chloride pipe; and at least herein embodying at least one set of bars having essentially the same outside diameter). Preferably, all connectors (including three-way elbow bar connector **108**, tee bar connector **112** and 90-degree elbow bar connector **116**) are nominal one-inch inside diameter industry-standard plastic connectors, preferably industry-standard polymerized vinyl chloride solid wall connectors, preferably industry-standard schedule 40 polymerized vinyl chloride solid wall connectors (at least herein embodying said at least four three-way elbow bar connectors comprise schedule 40 polymerized vinyl chloride; said at least four 90-degree elbow bar

connectors comprise schedule 40 polymerized vinyl chloride; and said at least four tee bar connectors comprise schedule 40 polymerized vinyl chloride; and at least herein embodying at least one set of connectors having essentially the same inside diameter). Preferably, use of industry-standard pipe and connectors allows a reliable dry friction fit between the bars and connectors. Upon reading the teachings of this specification, those with ordinary skill in the art will now understand that, under appropriate circumstances, considering issues such as cost, material availability, weight, durability, infant safety, market demand, etc., other pipe arrangements, such as, for example, the use of polymerized vinyl chloride pipe with other diameters such as nominal outside diameters of 1½ inches, 2 inches, etc., may suffice. Upon reading the teachings of this specification, those with ordinary skill in the art will now understand that, under appropriate circumstances, considering issues such as cost, material availability, weight, durability, infant safety, market demand, etc., other connector arrangements, such as, for example, the use of polymerized vinyl chloride connectors with other inside diameters such as nominal inside diameter of 1½ inches, nominal inside diameter of 2 inches, etc., may suffice.

Preferably, each upper side bar **104** and each lower side bar **118** are essentially the same length. Preferably, each upper side bar **104** and each lower side bar **118** are about 30 inches in length. Preferably, each attacher bar **110** is about 15 inches in length (length adjustable embodiments are discussed in FIG. 17). Preferably, each upper end bar **106** and each lower end bar **114** are essentially the same length. Preferably, upper end bar **106** and lower end bar **114** are about eight inches in length. Upon reading the teachings of this specification, those with ordinary skill in the art will now understand that, under appropriate circumstances, considering issues such as cost, material availability, weight, durability, infant safety, market demand, etc., other bar length arrangements, such as, for example, an upper side bar and lower side bar with other lengths, such as about 36 inches, and an upper end bar and a lower end bar with other lengths, such as about 9 inches, etc., may suffice.

FIG. 3 shows the section 3-3 of FIG. 2 illustrating a preferred component fit method for the infant activity system according to the preferred embodiment of FIG. 2. An example of all pipe and connector connections is shown in the section view 3-3 where, for example, a lower end bar **114** and a lower side bar **118** are preferably dry-fitted into a 90-degree elbow bar connector **116**. Preferably, this dry-fit system allows the infant activity system **100** to be assembled by hand, without the use of tools, adhesives or fasteners, which greatly simplifies the assembly/disassembly process for the user (at least herein embodying assembling such at least one set of bars and such at least one set of connectors without tools to produce such at least one infant activity system). Additionally, the close tolerances of industry-standard schedule 40 polymerized vinyl chloride solid wall connectors and industry-standard

schedule 40 polymerized vinyl chloride solid wall pipes preferably allow the infant activity system **100** to be very stable.

FIG. 4 shows a top elevational view of the infant activity system **100** according to the preferred embodiment of FIG. 2.

FIG. 5 shows an end elevational view of the infant activity system **100** according to the preferred embodiment of FIG. 2.

FIG. 6 shows a bottom elevational view of the infant activity system according to the preferred embodiment of FIG. 2.

FIG. 7 shows a side elevational view of infant activity system **100** according to the preferred embodiment of FIG. 2.

FIG. 8 shows the preferred infant activity system kit **200**, illustrating the primary components used to assemble the infant activity system according to the preferred embodiment of FIG. 2 (at least herein embodying wherein said at least one side bar set, said at least one attacher bar set, said at least one end bar set, and said at least one connector set are assembled to provide said infant activity system; and at least herein embodying providing at least one set of modular components). The infant activity system **100** is preferably provided as an infant activity system kit **200** that preferably comprises, as shown:

at least one side bar set **203** comprising at least four side bars **204** of essentially equal length (at least herein embodying at least one side bar set; and at least herein embodying wherein said at least one side bar set comprises at least four side bars, each of essentially equal length);

at least one attacher bar set **209** comprising at least four attacher bars **210** of essentially equal length (at least herein embodying at least one attacher bar set; and at least herein embodying wherein said at least one attacher bar set comprises at least four attacher bars, each of essentially equal length);

at least one end bar set **205** comprising at least eight end bars **206** of essentially equal length (at least herein embodying at least one end bar set; and at least herein embodying wherein said at least one end bar set comprises at least eight end bars, each of essentially equal length);

at least one connector set **211** comprising at least four three-way elbow bar connectors **208**, at least four 90-degree elbow bar connectors **216**, and at least four tee bar connectors **212** (at least herein embodying at least one connector set; and at least herein embodying wherein said at least one connector set comprises: at least four three-way elbow bar connectors; at least four 90-degree elbow bar connectors; and at least four tee bar connectors); at least one flexible bag container **202** (at least one container at least one container); and at least one assembly instruction sheet **218** (at least herein embodying at least one assembly instruction sheet).

Preferably, both the flexible bag container 202 and the assembly instruction sheet 218 will include the product name indicia 220 (at least herein embodying at least one indicia). Preferably, the flexible bag container 202 is reusable and intended to allow all components of the disassembled infant activity system 100 to be conveniently and easily stored (at least herein embodying wherein said at least one container allows easy storage of such at least one infant activity system after disassembly).

Preferably, all components may be color-coded using a variety of colors to facilitate assembly and/or to improve marketability of the infant activity system 100. Preferably, side bar 204 and/or end bar 206 may be color-coded in one color, preferably red (at least herein embodying wherein said at least four side bars comprise color coding; and at least herein embodying wherein said at least eight end bars comprise color coding). Preferably, attacher bar 210 may be color-coded in one color, preferably blue (at least herein embodying wherein said at least four attacher bars comprise color coding). Preferably, essentially each three-way elbow bar connector 208, tee bar connector 212 and 90-degree elbow bar connector 216 may be color-coded in one color, preferably white (at least herein embodying wherein: said at least four three-way elbow bar connectors comprise color coding said at least four 90-degree elbow bar connectors comprise color coding; and said at least four tee bar connectors comprise at least one color coded-element).

Infant activity system kit 200 of FIG. 8 shows a preferred embodiment illustrating the primary components of the kit preferably used to make up infant activity system 100.

FIG. 9 shows a perspective view of side bar extender set 300 of infant activity system kit 200 of FIG. 8, according to a preferred embodiment of the present invention. FIG. 10 shows an exploded perspective view of side bar extender set 300 of FIG. 9, including partially assembled components of infant activity system kit 200. Preferred embodiments of infant activity system kit 200 comprise side bar extender set 300, as shown (at least embodying herein at least one side bar extender set; wherein such at least one side bar extender set comprises at least four side extender bars, each of essentially equal length; and at least four linear bar connectors). Preferably, side bar extender set 300 is adapted to lengthen side bars 204 of infant activity system 100, as shown. Preferably, each side bar extender 301 of side bar extender set 300 comprises side bar 204a and linear bar connector 302, as shown. Preferably, side bar 204a and linear bar connector 302 are interconnectable with the above-described components of infant activity system 100, as shown. Preferably, side bar 204a and linear bar connector 302 are constructed from materials substantially matching those of infant activity system 100. Preferably, side bar extender set 300 comprises four side bars 204a and four linear bar connectors 302, as shown. Upon reading the teachings of this specification, those with ordinary skill in the art will now understand that, under appropriate circumstances, considering issues such as commercial markets, intended use, etc., other kit

arrangements, such as, for example, supplying extender bars as the sole element of an upgrade kit, providing additional extender for other portions of the system, etc., may suffice.

Preferably, to provide added user convenience, portions of infant activity system kit 200 are factory preassembled (at least embodying herein wherein said at least one attacher bar set, said at least one end bar set, and said at least one connector set are factory pre-assembled). Preferably, end bar set 205, attacher bar set 209, and connector set 211, are preassembled at the factory prior to shipping, as shown. Upon reading the teachings of this specification, those with ordinary skill in the art will now understand that, under appropriate circumstances, considering issues such as preferred shipping size, intended use, etc., other kit arrangements, such as, for example, providing fully assembled units, etc., may suffice. Furthermore, upon reading the teachings of this specification, those with ordinary skill in the art will now understand that, under appropriate circumstances, considering issues such as cost, consumer demand etc., other end support arrangements, such as, for example, producing a unitary molded unit replacing the end bar set, attacher bar set, and connector set, etc., may suffice.

FIG. 11 shows a perspective view of attachable play feature 401 of infant activity system kit 200 of FIG. 8, according to a preferred embodiment of the present invention. FIG. 12 shows a perspective view of attachable play feature 401 of FIG. 10, removably mounted to infant activity system 100. Preferred embodiments of infant activity system kit 200 further comprise attachable play features 401 adapted to enhance the functionality of infant activity system 100 (at least embodying herein at least one removably attachable play feature adapted to removably attach to such at least one infant activity system). FIG. 11 and FIG. 12 illustrate the use of attachable play feature 401 having a sports related theme, in conjunction with infant activity system 100, as shown. More specifically, FIG. 11 and FIG. 12 illustrate the use of attachable play feature 401 comprising basketball hoop 402 (at least embodying herein wherein such at least one removably attachable play feature comprises at least one sports related function and such at least one removably attachable play feature comprises at least one basketball hoop). Preferably, basketball hoop 402 is of a type used with basketballs of reduced size, especially basketballs of foam construction. Preferably, basketball hoop 402 comprises a hoop diameter of about six inches and a backboard dimension of about 12 inches by 12 inches, as shown. Preferably, basketball hoop 402 is constructed from an appropriately durably material, most preferably plastic. Upon reading the teachings of this specification, those with ordinary skill in the art will now understand that, under appropriate circumstances, considering issues such as sport theme, intended use, etc., the use of other basketball hoop features, such as, for example, team logos, indicia, etc., may suffice.

Preferably, attachable play feature 401 is adaptable to comprise a wide range of sports related attachments including goal net 404 (as depicted in FIG. 12 with dashed lines),

as shown. Preferably, goal net **404** is adapted to convert infant activity system **100** to an alternate sports related use, preferably a soccer or hockey goal, as shown. Upon reading the teachings of this specification, those of ordinary skill in the art will now understand that, under appropriate circumstances, considering such issues as intended use, age of user, regional activity preference, etc., other sport arrangements, such as, for example, converting the system for use as a football training target, golf drive practice net, etc., may suffice.

FIG. 13 shows the sectional view 13-13 of FIG. 12. Preferably, basketball hoop **402** comprises coupler support **406**, as shown. Preferably, coupler support **406** is adapted to support basketball hoop **402** by engaging a horizontally oriented bar **450** of infant activity system **100**, as shown. Preferably, basketball hoop **402** is adapted to be stabilized by one or more vertically oriented bars **452** of infant activity system **100**, as shown.

FIG. 14 shows a perspective view of another attachable play feature **401** of infant activity system kit **200** of FIG. 8. Preferred embodiments of infant activity system kit **200** further comprise soft toy embodiments of attachable play feature **401**, such as soft toy **408**, as shown (at least embodying herein at least one soft toy; wherein said at least one soft toy comprises at least one removable attacher adapted to removably attach said at least one soft toy to said infant activity system). Preferably, soft toy **408** comprises at least one removable fastener, preferably a hook-and-loop fastener identified herein as fastener **410**. Preferably, fastener **410** is adapted to firmly hold soft toy **408** suspended above the child user while providing a breakaway safety feature if more than a predetermined weight is applied to soft toy **408**.

FIG. 15 shows a perspective view of another preferred embodiment of attachable play feature **401** of infant activity system kit **200** of FIG. 8. Preferably, soft toy **408** of FIG. 15 has been located to draw the child user into walking the length of infant activity system **100**.

FIG. 16 shows a perspective view of another attachable play feature **401** of the infant activity system kit **200** of FIG. 8. Preferably, attachable play feature **401** of FIG. 15 comprises cover **420**, as shown. Preferably, cover **420** is adapted to drape infant activity system **100** thus providing a "tent-like" structure for imagined play. Preferably, cover **420** comprises one or more hook-and-loop (or similar) fasteners **422** to assist in securing cover **420** to infant activity system **100**, as shown.

Preferably, cover **420** (at least embodying herein at least one cover adapted to cover at least one portion of said infant activity system) is constructed from soft/flexible fabric materials, as shown. Upon reading the teachings of this specification, those with ordinary skill in the art will now understand that, under appropriate circumstances, considering issues such as intended use, etc., the inclusion of other cover features, such as, for example, themed indicia, storage pockets, windows, inflatable sections, soft padding including safety padding, etc., may suffice.

FIG. 17 shows a perspective view of a length adjustable attacher bar **310**, of infant

activity system 100, according to an alternate preferred embodiment of the present invention. Alternate preferred embodiments of infant activity system 100 preferably comprise length-adjustable attacher bars 310 adapted to adjust the height (distance) of upper side bars 104 relative to the lower polygonal peripheral support 109, as shown (at least embodying herein wherein said at least one upper polygonal peripheral graspable bar is user adjustable to at least two fixed elevation positions relative to said at least one lower polygonal peripheral support). Preferably, the available adjustment is in the range of several inches. This preferred alternate feature allows the system to better accommodate older children. Preferably, length-adjustable attacher bars 310 comprise a telescoping sleeve arrangement having a locking mechanism 311, preferably comprising an interlocking "spring-button and hole" arrangement 312, as shown. Upon reading the teachings of this specification, those with ordinary skill in the art will now understand that, under appropriate circumstances, considering such issues as economics, user preference, ease of use, manufacturing preferences, etc., other leg height adjusting mechanisms, such as friction clamps, threaded locks, pins, screws, longer length support bars, etc. may suffice.

Although applicant has described applicant's preferred embodiments of this invention, it will be understood that the broadest scope of this invention includes modifications such as diverse shapes, sizes, and materials. Such scope is limited only by the below claims as read in connection with the above specification.

Further, many other advantages of applicant's invention will be apparent to those skilled in the art from the above descriptions and the below claims.

What is claimed is:

- 1) An infant activity system, relating to providing unrestricted learning-to-walk oriented play activities to at least one infant, comprising:
 - a) upper polygonal peripheral graspable bar means for grasping by the at least one infant;
 - b) lower polygonal peripheral support means for supporting said upper polygonal peripheral graspable bar means in at least one fixed elevation position; and
 - c) geometry means for permitting essentially free movement by the at least one infant throughout said infant activity system.
- 2) The infant activity system, according to Claim 1, wherein said geometry means comprises tilt-prevention means for essentially preventing tilting of said infant activity system when the at least one infant applies forces to said upper polygonal peripheral graspable bar means.
- 3) The infant activity system, according to Claim 2, wherein said lower polygonal peripheral support means comprises lower polygonal peripheral base means surrounding at least one base area for providing at least one lower polygonal peripheral base for said infant activity system.
- 4) The infant activity system, according to Claim 3, wherein said tilt-prevention means comprises geometric retention means for geometrically retaining at least one center of gravity of said infant activity system within such at least one base area when the at least one infant applies forces to said upper polygonal peripheral graspable bar means.
- 5) The infant activity system, according to Claim 3, further comprising attacher means for attaching said upper polygonal peripheral graspable bar means to said lower polygonal peripheral support means.
- 6) An infant activity system relating to providing unrestricted activities to at least one infant comprising in combination:
 - a) at least one upper polygonal peripheral graspable bar adapted to be grasped by the at least one infant;
 - b) at least one lower polygonal peripheral support adapted to support said at least one upper polygonal peripheral graspable bar in at least one fixed elevation position; and
 - c) at least one geometric arrangement adapted to permit essentially free movement by the at least one infant throughout said infant activity system.
- 7) The infant activity system, according to Claim 6, wherein said at least one geometric arrangement comprises at least one tilt-prevention arrangement adapted to essentially

prevent tilting of said infant activity system when the at least one infant applies forces to said at least one upper polygonal peripheral graspable bar.

- 8) The infant activity system, according to Claim 6, wherein said lower polygonal peripheral support comprises:
- a) at least one lower polygonal peripheral base surrounding at least one base area;
 - b) wherein at least one geometric relationship between said at least one lower polygonal peripheral base and said at least one upper polygonal peripheral graspable bar permits retention of at least one center of gravity of said infant activity system within such at least one base area when the at least one infant applies forces to said upper polygonal peripheral graspable bar; and
 - c) at least one attacher adapted to attach said at least one lower polygonal peripheral base to said at least one upper polygonal peripheral graspable bar.
- 9) The infant activity system, according to Claim 8, wherein said at least one lower polygonal peripheral base comprises:
- a) at least six end bars, each of essentially equal length;
 - b) at least two side bars, each of essentially equal length;
 - c) at least four 90-degree elbow bar connectors; and
 - d) at least four tee bar connectors.
- 10) The infant activity system, according to Claim 8, wherein said at least one attacher comprises at least four attacher bars, each of essentially equal length.
- 11) The infant activity system, according to Claim 6, wherein said at least one upper polygonal peripheral graspable bar comprises:
- a) at least two end bars, each of essentially equal length;
 - b) at least two side bars, each of essentially equal length; and
 - c) at least four three-way elbow bar connectors.
- 12) The infant activity system, according to Claim 6 wherein said at least one upper polygonal peripheral graspable bar is user adjustable to at least two fixed elevation positions relative to said at least one lower polygonal peripheral support.
- 13) A kit system for assembling at least one infant activity system relating to providing unrestricted learning-to-walk activities to at least one infant comprising:
- a) at least one side bar set;
 - b) at least one attacher bar set;
 - c) at least one end bar set;
 - d) at least one connector set;
 - e) at least one container;
 - f) at least one assembly instruction sheet; and

- g) at least one indicia;
 - h) wherein said at least one side bar set, said at least one attacher bar set, said at least one end bar set, and said at least one connector set are assembled to provide said infant activity system.
- 14) The kit system, according to Claim 13, wherein said at least one side bar set comprises at least four side bars, each of essentially equal length.
- 15) The kit system, according to Claim 14, wherein said at least four side bars comprise schedule 40 polymerized vinyl chloride.
- 16) The kit system, according to Claim 14, wherein said at least four side bars comprise color coding.
- 17) The kit system, according to Claim 13, wherein said at least one end bar set comprises at least eight end bars, each of essentially equal length.
- 18) The kit system, according to Claim 17, wherein said at least eight end bars comprise schedule 40 polymerized vinyl chloride.
- 19) The kit system, according to Claim 17, wherein said at least eight end bars comprise color coding.
- 20) The kit system, according to Claim 13, wherein said at least one connector set comprises:
- a) at least four three-way elbow bar connectors;
 - b) at least four 90-degree elbow bar connectors; and
 - c) at least four tee bar connectors.
- 21) The kit system, according to Claim 20, wherein:
- a) said at least four three-way elbow bar connectors comprise schedule 40 polymerized vinyl chloride;
 - b) said at least four 90-degree elbow bar connectors comprise schedule 40 polymerized vinyl chloride; and
 - c) said at least four tee bar connectors comprise schedule 40 polymerized vinyl chloride.
- 22) The kit system, according to Claim 20, wherein:
- a) said at least four three-way elbow bar connectors comprise color coding;
 - b) said at least four 90-degree elbow bar connectors comprise color coding; and
 - c) 23said at least four tee bar connectors comprise color coding.
- 23) The kit system, according to Claim 13, wherein said at least one attacher bar set comprises at least four attacher bars, each of essentially equal length.
- 24) The kit system, according to Claim 23, wherein said at least four attacher bars comprise schedule 40 polymerized vinyl chloride pipe.

- 25) The kit system, according to Claim 23, wherein said at least four attacher bars comprise color coding.
- 26) The kit system, according to Claim 13, wherein said at least one container permits easy storage of such at least one infant activity system after disassembly.
- 27) The kit system, according to Claim 13, wherein said at least one attacher bar set, said at least one end bar set, and said at least one connector set are factory pre-assembled.
- 28) The kit system, according to Claim 13 further comprising:
- a) at least one side bar extender set;
 - b) wherein said at least one side bar extender set comprises
 - i) at least four side extender bars, each of essentially equal length, and
 - ii) at least four linear bar connectors.
- 29) The kit system, according to Claim 13 further comprising at least one removably attachable play feature adapted to removably attach to such at least one infant activity system.
- 30) The kit system, according to Claim 29 wherein said at least one removably attachable play feature comprises at least one sports related theme.
- 31) The kit system, according to Claim 29 wherein said at least one removably attachable play feature comprises at least one basketball hoop.
- 32) The kit system, according to Claim 29 wherein said at least one removably attachable play feature comprises at least one goal net.
- 33) The kit system, according to Claim 29 wherein said at least one removably attachable play feature comprises:
- a) at least one soft toy;
 - b) wherein said at least one soft toy comprises at least one removable attacher adapted to removably attach said at least one soft toy to said infant activity system.
- 34) The kit system, according to Claim 29 wherein said at least one removably attachable play feature comprises at least one cover adapted to cover at least one portion of said infant activity system.

- 35) An infant activity system assembly method for at least one infant activity system, relating to providing unrestricted learning-to-walk oriented play activities to at least one infant, comprising upper polygonal peripheral graspable bar means for providing at least one polygonal peripheral graspable bar for grasping by such at least one infant; lower polygonal peripheral support means for supporting such upper polygonal peripheral graspable bar means in at least one fixed elevation position; and geometry means for permitting essentially free movement by such at least one infant throughout such infant activity system, comprising the steps of:
- a) providing at least one set of modular components;
 - b) wherein such at least one set of modular components comprises
 - i) at least one set of bars having essentially the same outside diameter, and
 - ii) at least one set of connectors having essentially the same inside diameter; and
 - c) assembling such at least one set of bars and such at least one set of connectors without tools to produce such at least one infant activity system.
- 36) The infant activity system assembly method, according to Claim 35, wherein such at least one set of bars comprises:
- a) at least eight end bars, each of essentially equal length;
 - b) at least four side bars, each of essentially equal length; and
 - c) at least four attacher bars, each of essentially equal length.
- 37) The infant activity system assembly method, according to Claim 35, wherein such at least one set of connectors comprises:
- a) at least four three-way elbow bar connectors;
 - b) at least four 90-degree elbow bar connectors; and
 - c) at least four tee bar connectors.
- 38) Claim 35, further comprising the step of providing at least one removably attachable play feature adapted to removably attach to such at least one infant activity system.

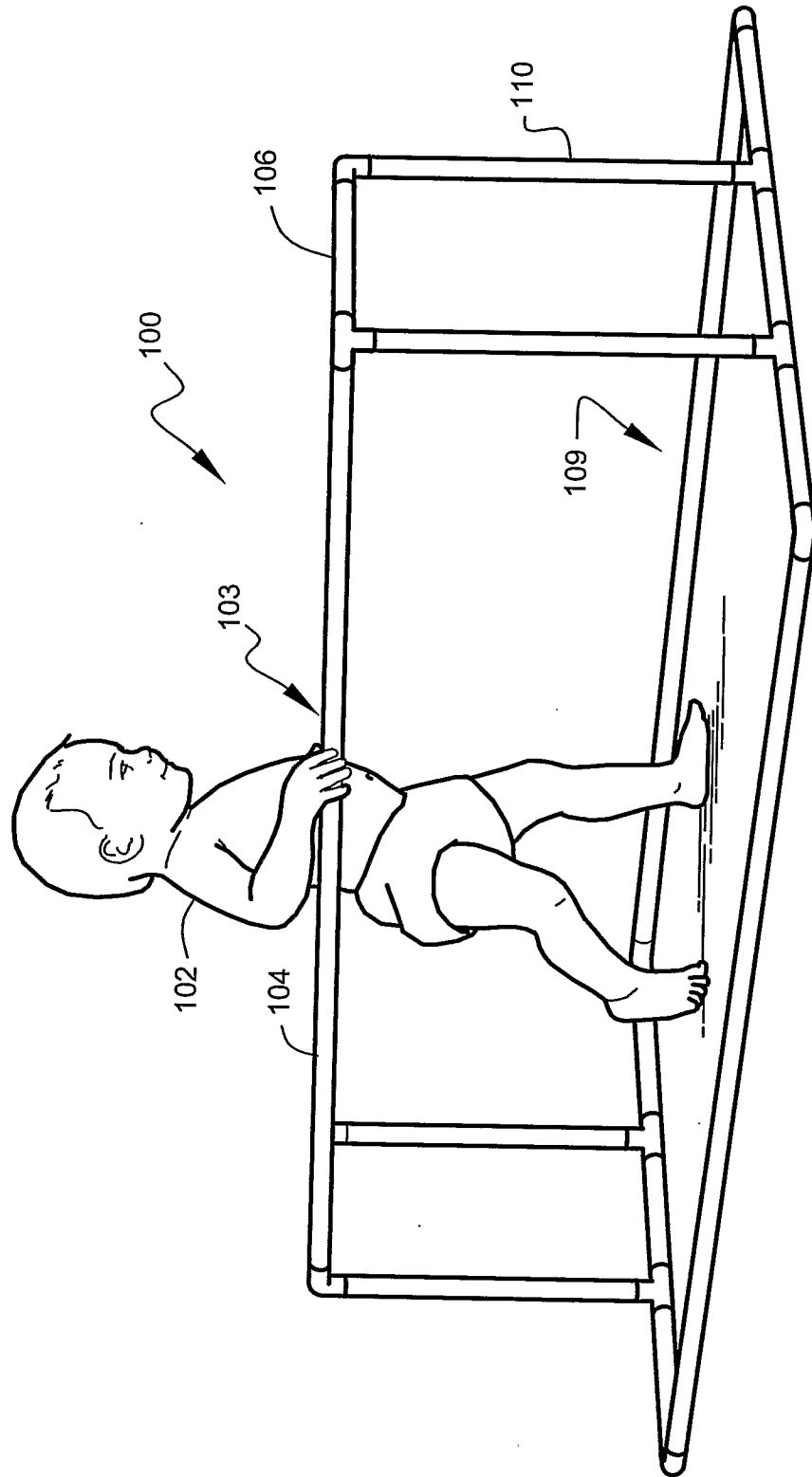

FIG. 1

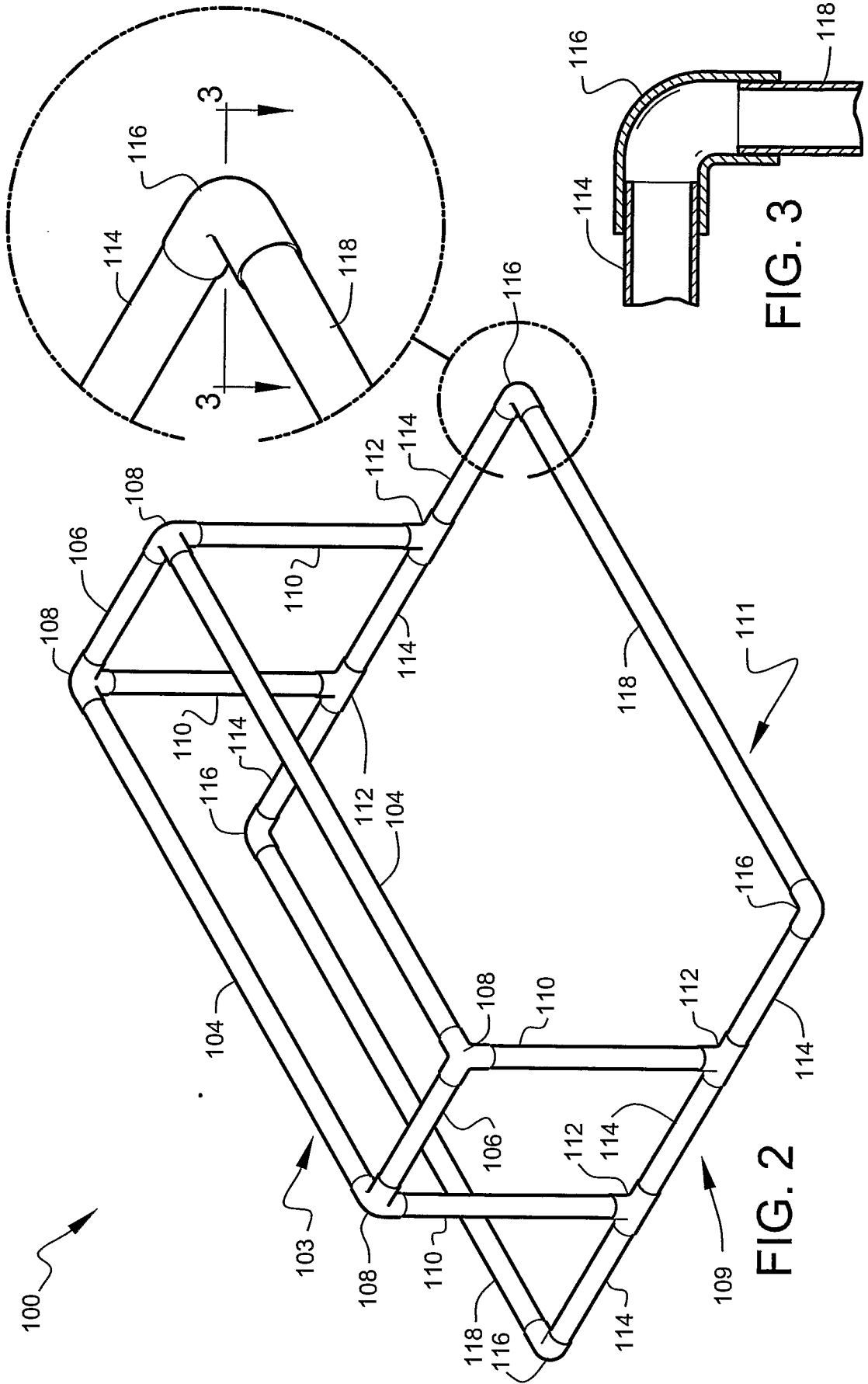

FIG. 3

FIG. 2

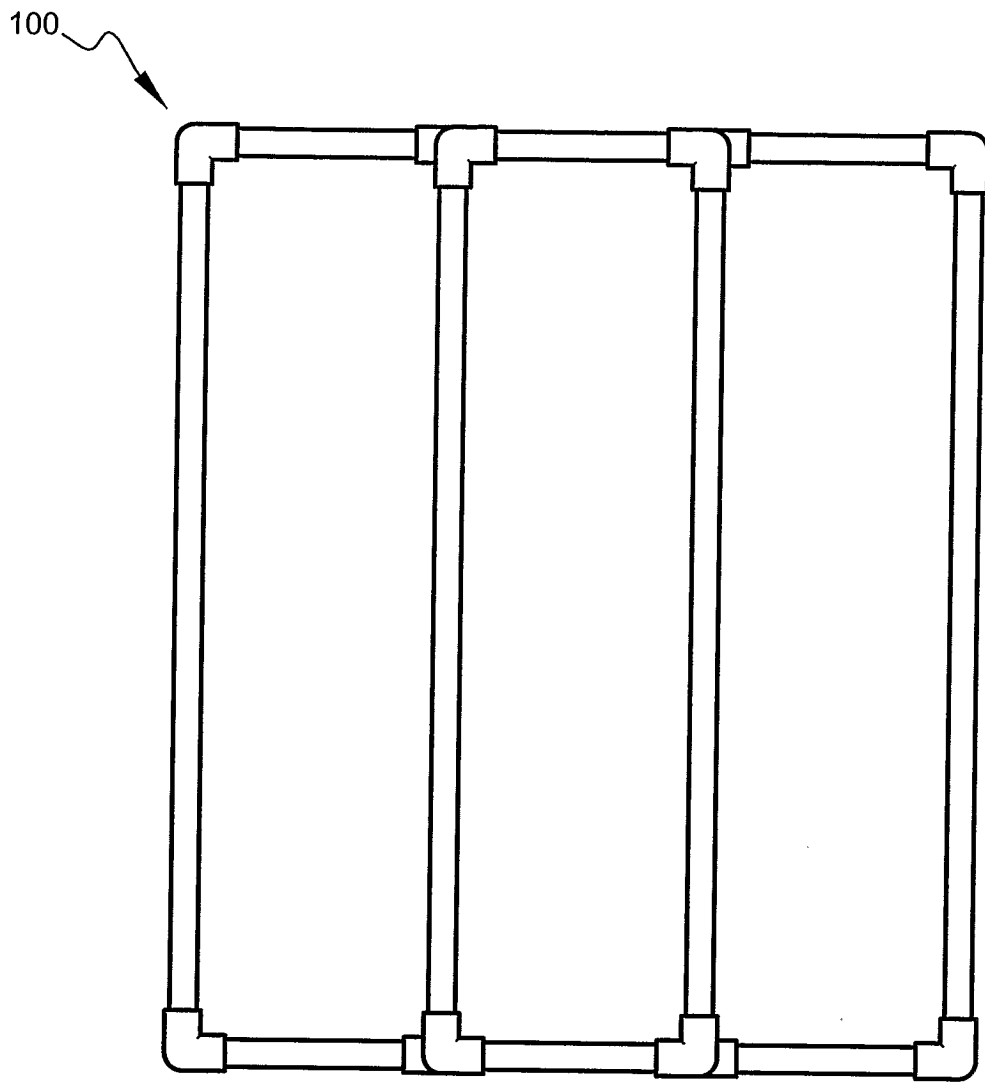

FIG. 4

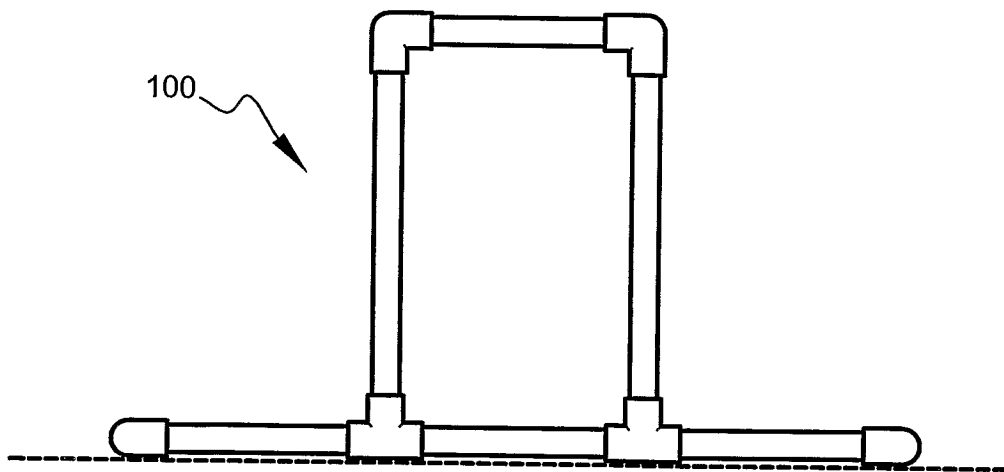

FIG. 5

100

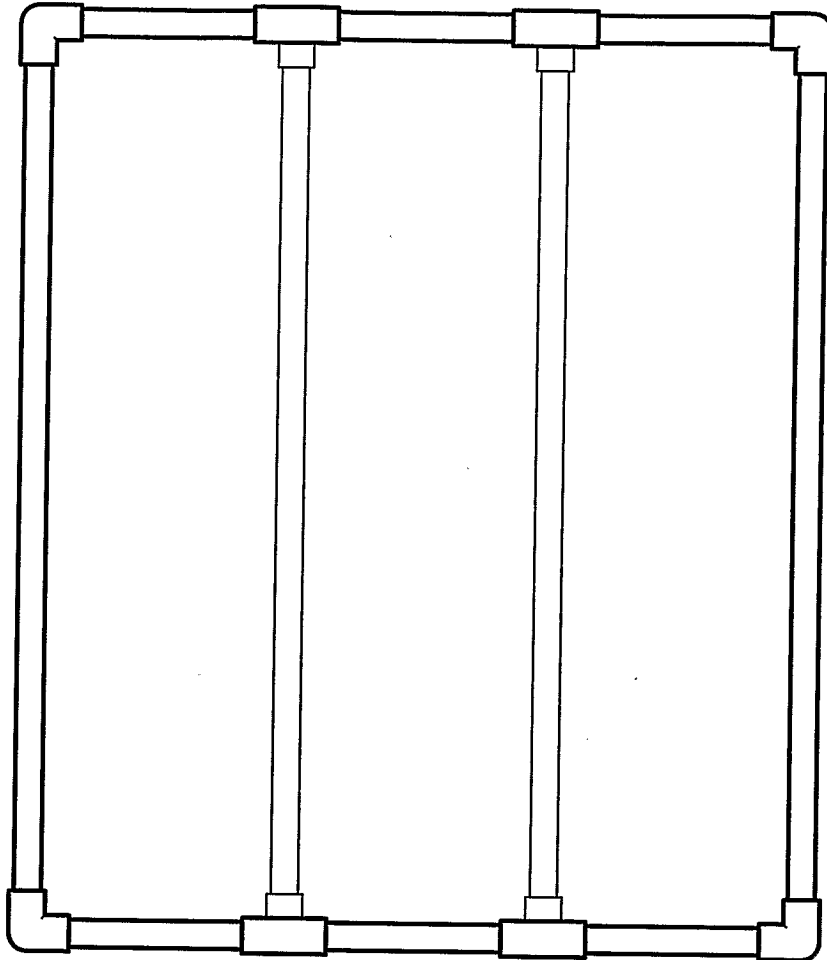

FIG. 6

100

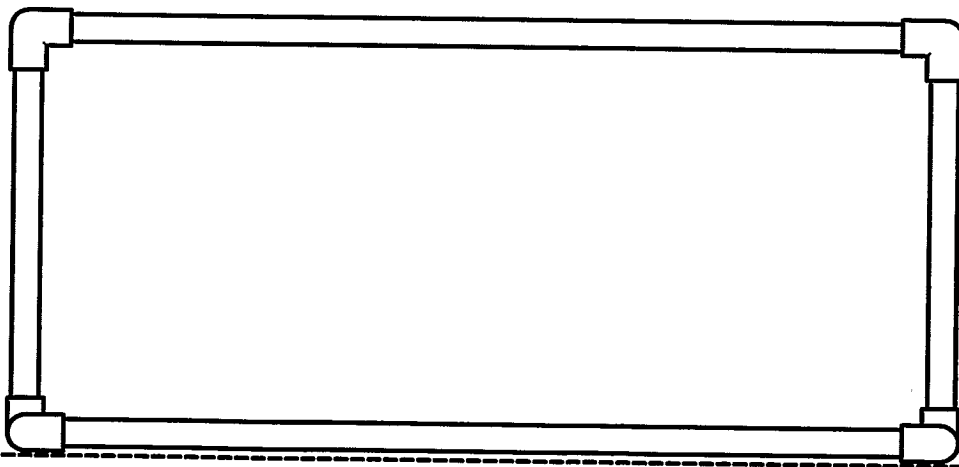
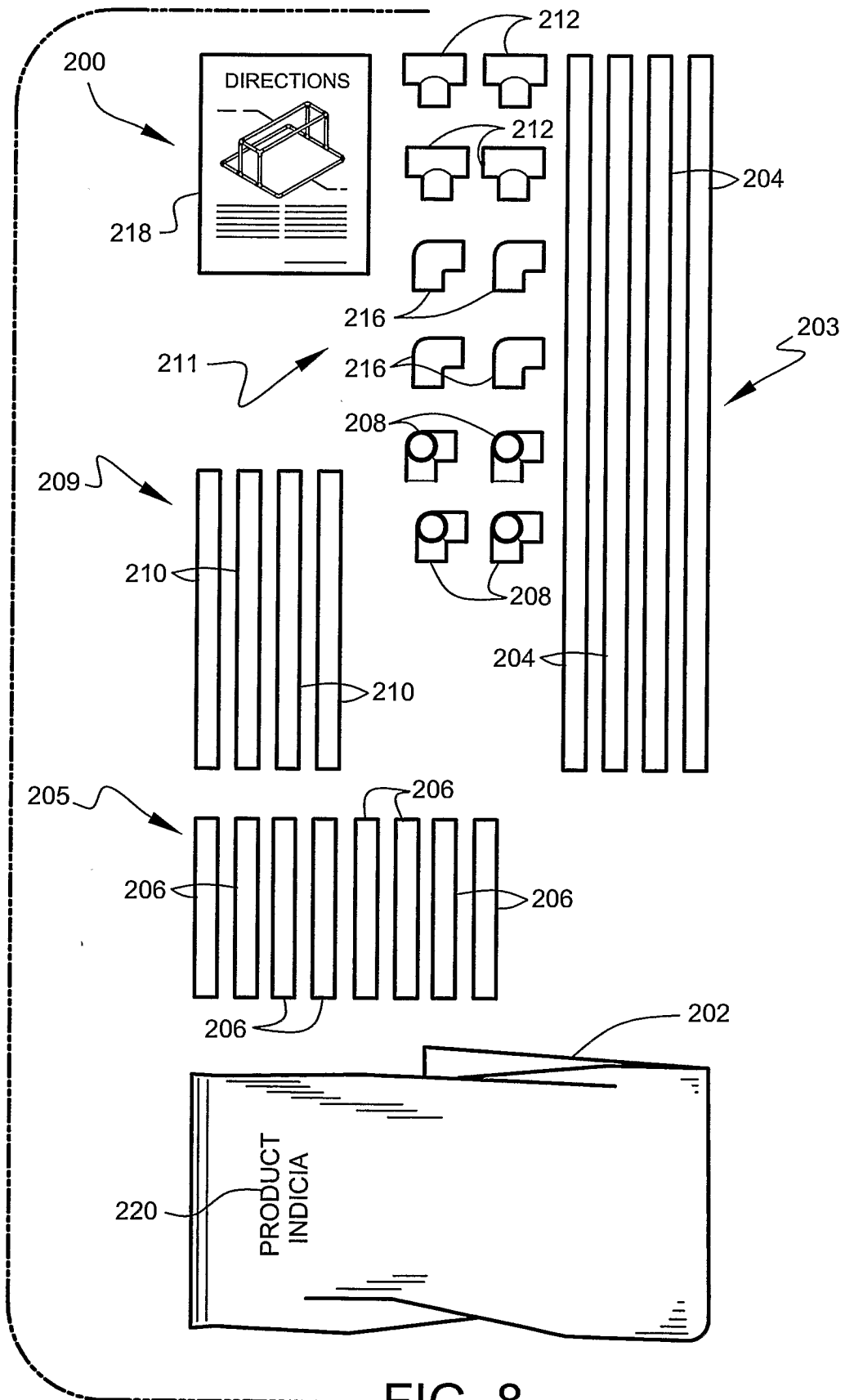

FIG. 7



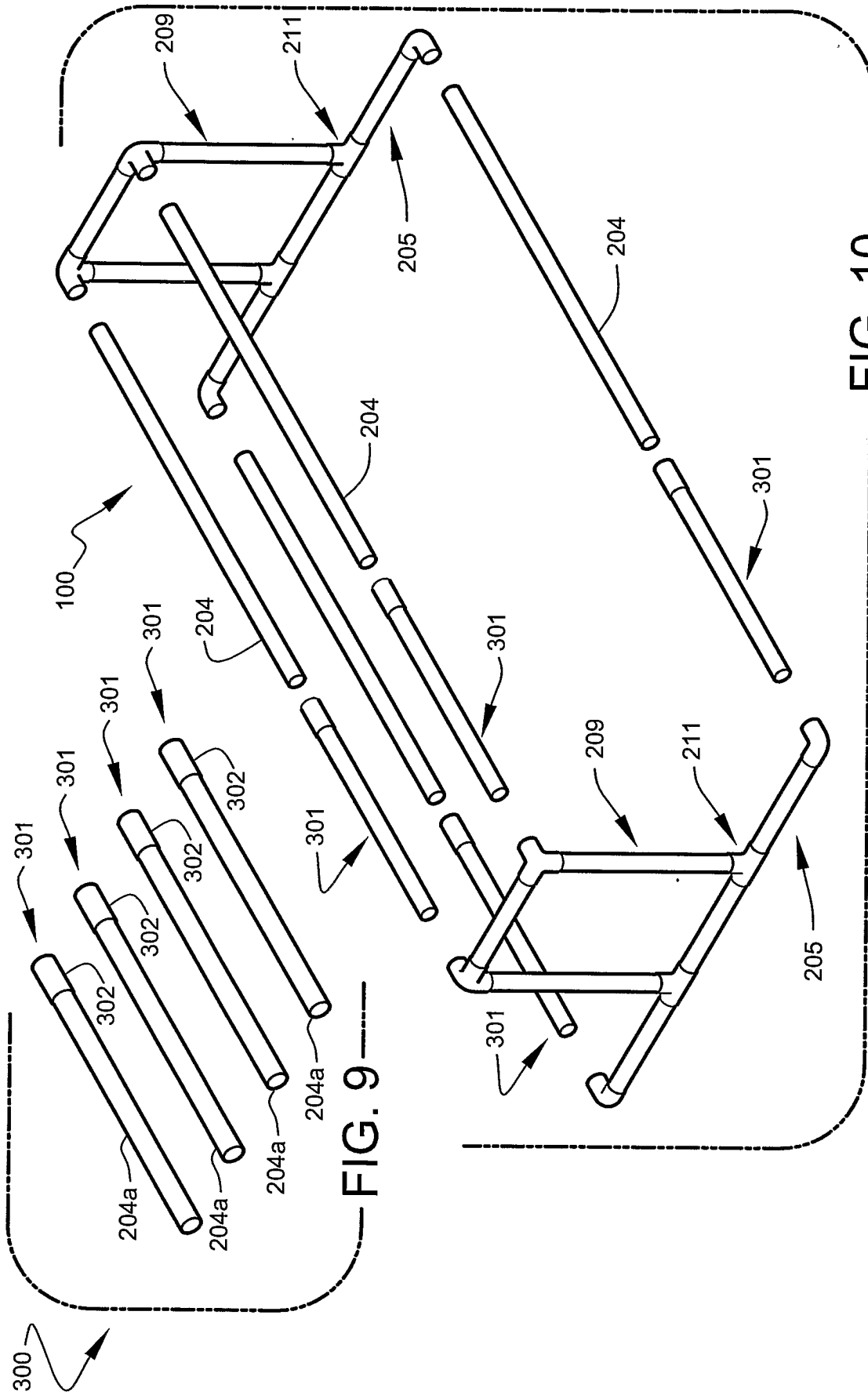

FIG. 9

FIG. 10

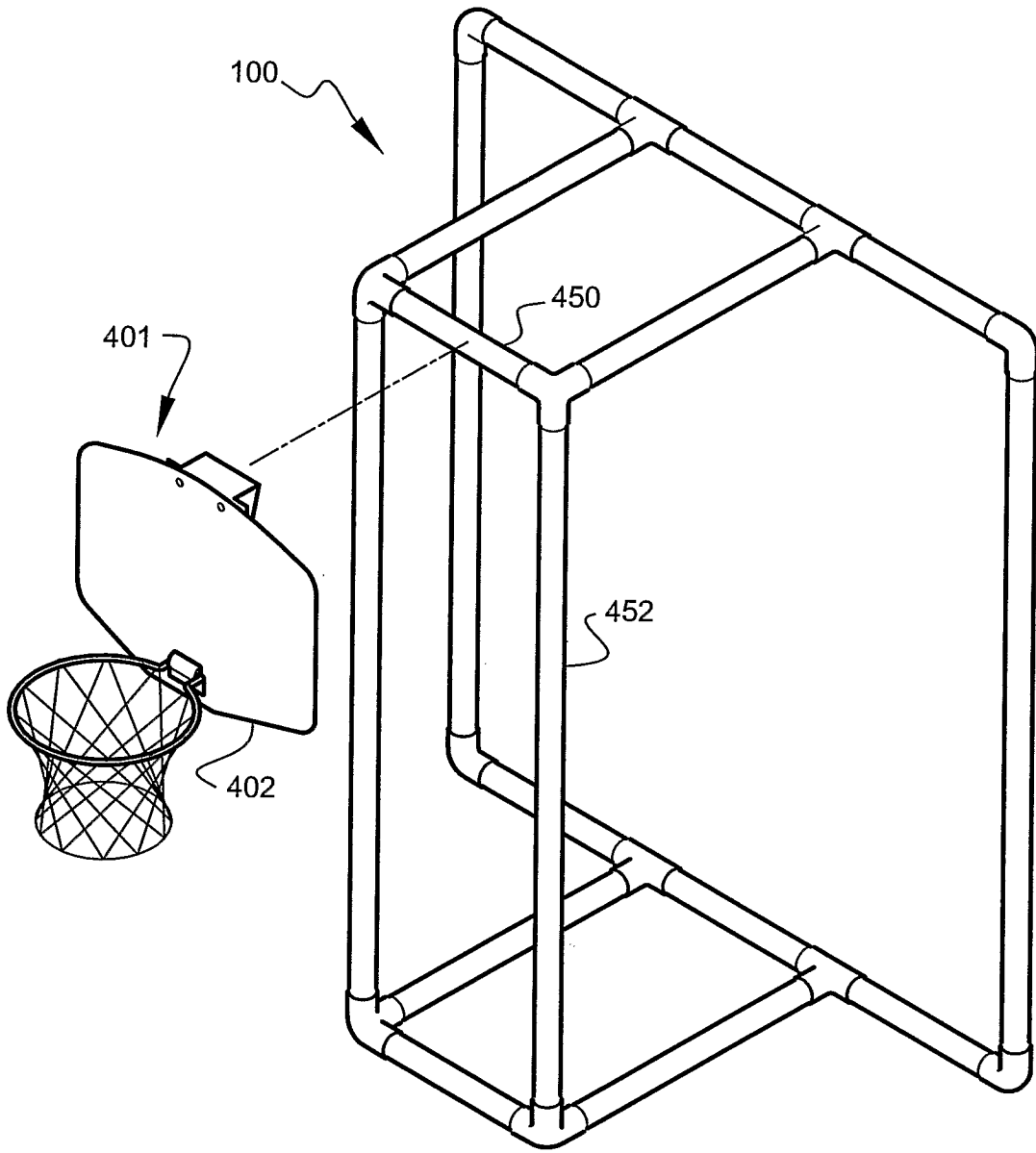

FIG. 11

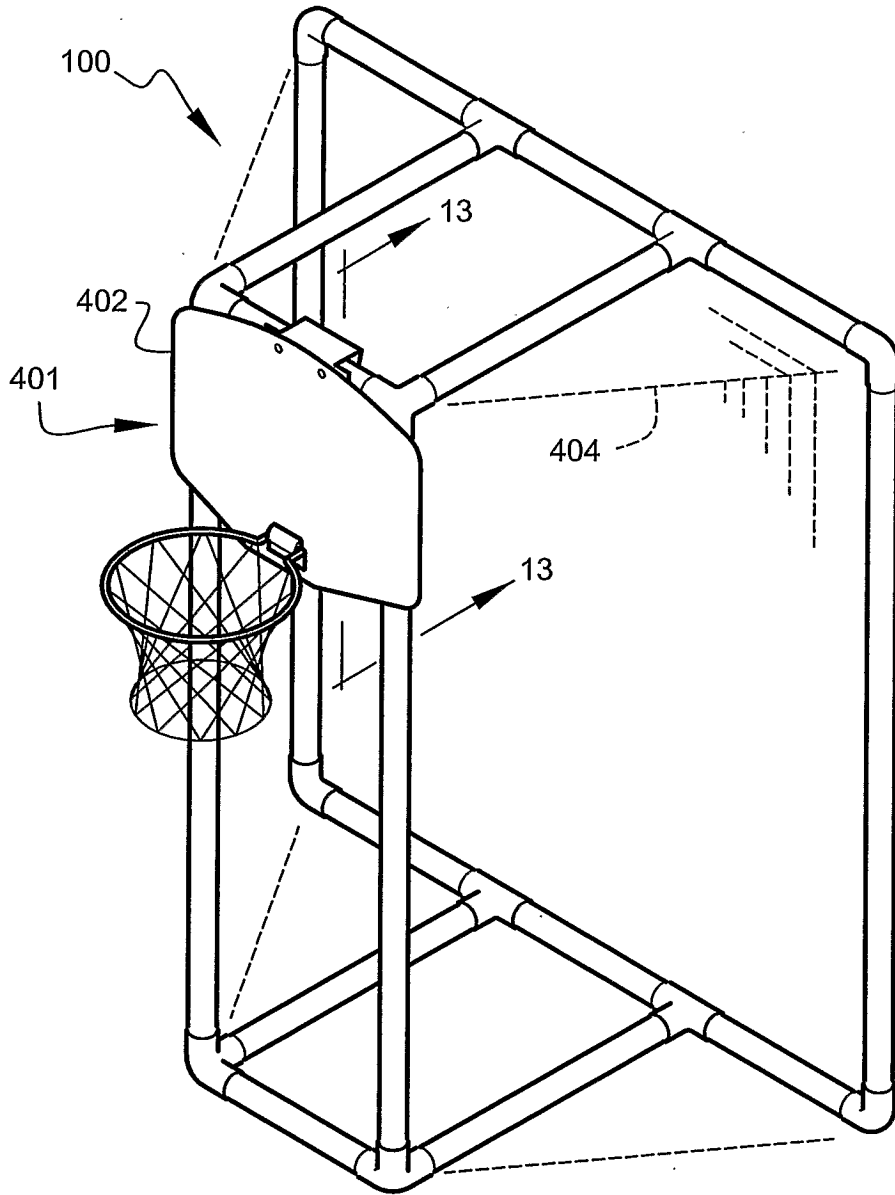

FIG. 12

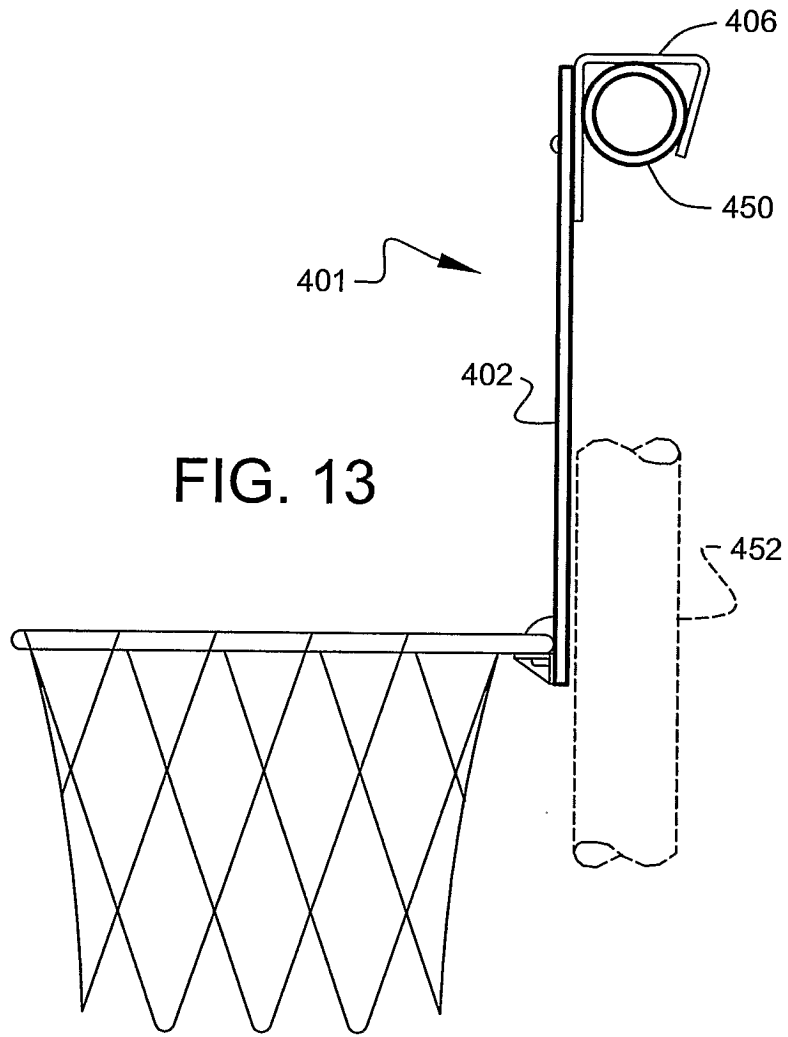

FIG. 13

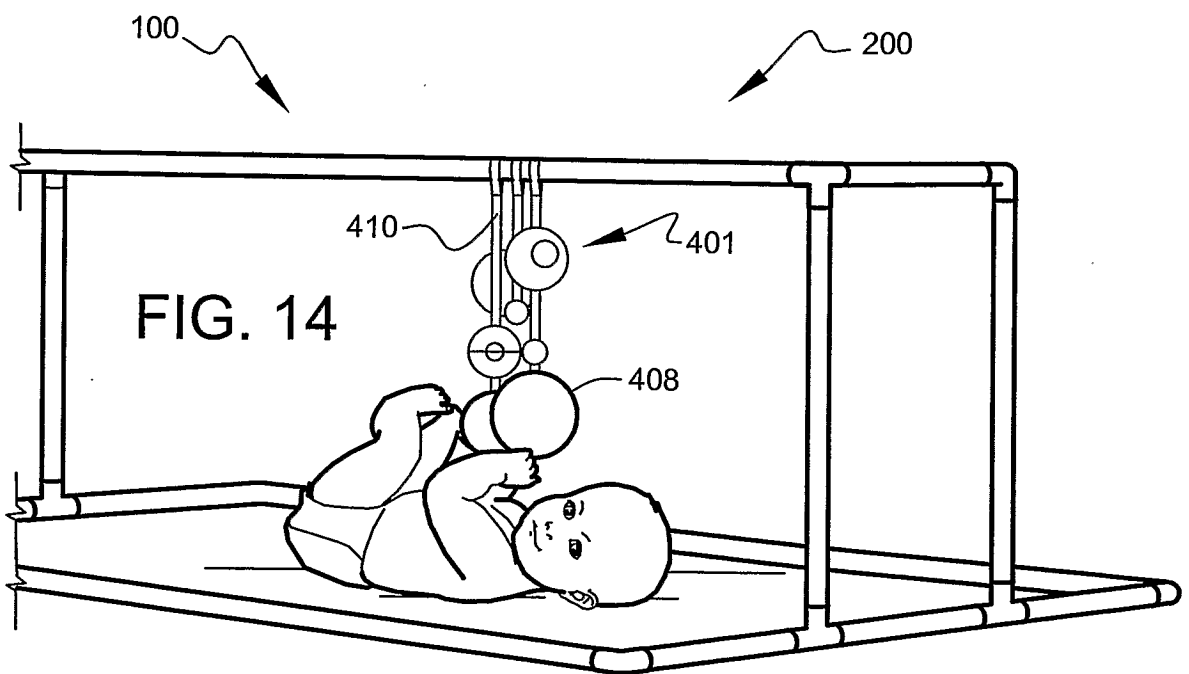

FIG. 14

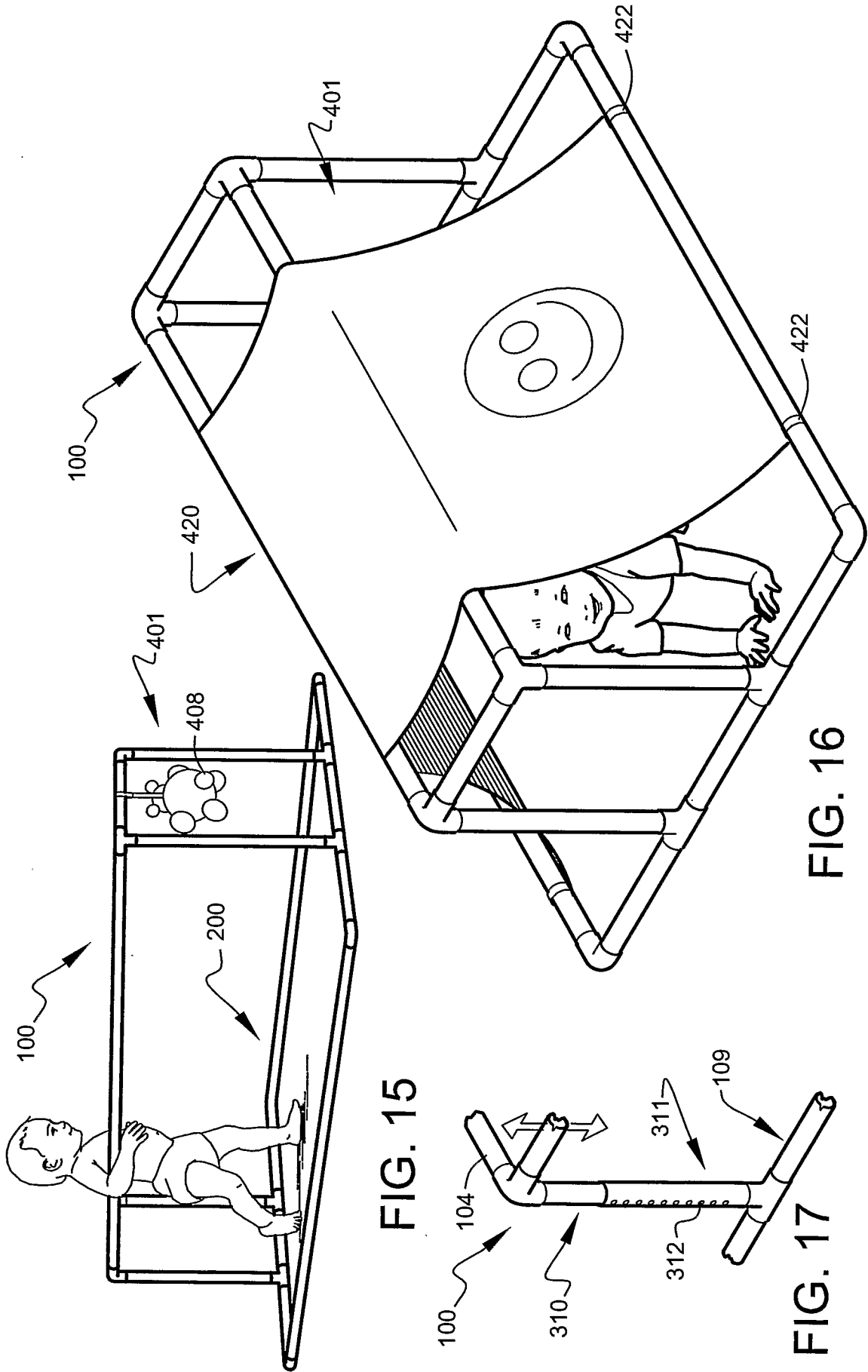

FIG. 15

FIG. 16

FIG. 17

(19) World Intellectual Property Organization
International Bureau



(43) International Publication Date
19 October 2006 (19.10.2006)

PCT

(10) International Publication Number
WO 2006/110438 A3

(51) International Patent Classification:
A63B 21/00 (2006.01) B62B 3/00 (2006.01)

KG, KM, KN, KP, KR, KZ, LC, LK, LR, LS, LT, LU, LV, LY, MA, MD, MG, MK, MN, MW, MX, MZ, NA, NG, NI, NO, NZ, OM, PG, PH, PL, PT, RO, RU, SC, SD, SE, SG, SK, SL, SM, SY, TJ, TM, TN, TR, TT, TZ, UA, UG, US, UZ, VC, VN, YU, ZA, ZM, ZW.

(21) International Application Number:
PCT/US2006/012764

(22) International Filing Date: 5 April 2006 (05.04.2006)

(84) Designated States (unless otherwise indicated, for every kind of regional protection available): ARIPO (BW, GH, GM, KE, LS, MW, MZ, NA, SD, SL, SZ, TZ, UG, ZM, ZW), Eurasian (AM, AZ, BY, KG, KZ, MD, RU, TJ, TM), European (AT, BE, BG, CH, CY, CZ, DE, DK, EE, ES, FI, FR, GB, GR, HU, IE, IS, IT, LT, LU, LV, MC, NL, PL, PT, RO, SE, SI, SK, TR), OAPI (BF, BJ, CF, CG, CI, CM, GA, GN, GQ, GW, ML, MR, NE, SN, TD, TG).

(25) Filing Language: English

(26) Publication Language: English

(30) Priority Data:
60/669,540 7 April 2005 (07.04.2005) US
60/713,286 31 August 2005 (31.08.2005) US
11/278,657 4 April 2006 (04.04.2006) US

Declaration under Rule 4.17:
— of inventorship (Rule 4.17(iv))

(71) Applicant and
(72) Inventor: MONAGHAN, Michael, J. [US/US]; 4461 N. Launfal Ave, Phoenix, Arizona 85018 (US).

Published:
— with international search report
— before the expiration of the time limit for amending the claims and to be republished in the event of receipt of amendments

(74) Agent: STONEMAN, Martin, L.; STONEMAN LAW OFFICES, LTD, 3113 North 3rd Street, Phoenix, Arizona 85012-2601 (US).

(88) Date of publication of the international search report:
6 December 2007

(81) Designated States (unless otherwise indicated, for every kind of national protection available): AE, AG, AL, AM, AT, AU, AZ, BA, BB, BG, BR, BW, BY, BZ, CA, CH, CN, CO, CR, CU, CZ, DE, DK, DM, DZ, EC, EE, EG, ES, FI, GB, GD, GE, GH, GM, HR, HU, ID, IL, IN, IS, JP, KE,

For two-letter codes and other abbreviations, refer to the "Guidance Notes on Codes and Abbreviations" appearing at the beginning of each regular issue of the PCT Gazette.

(54) Title: INFANT ACTIVITY SYSTEMS

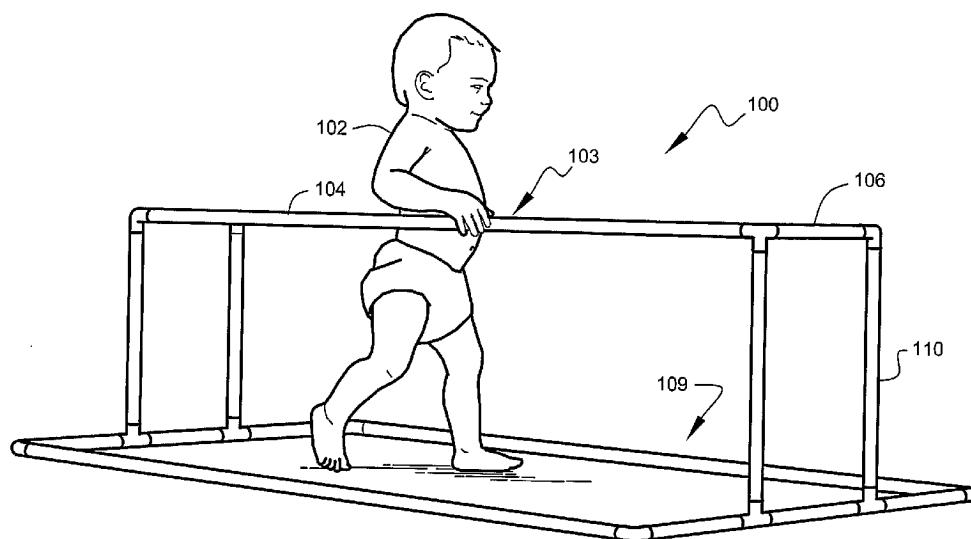

(57) Abstract: A safe and fun exercise and walking-training apparatus and method that is ideal for infants in the approximate age range of 10 months to 18 months is disclosed. The apparatus is lightweight, very sturdy, very simple, consisting of only six unique elements, and may be assembled and disassembled by hand without tools. A system of attachable play features is also disclosed.



WO 2006/110438 A3

INTERNATIONAL SEARCH REPORT

International application No.

PCT/US06/12764

A. CLASSIFICATION OF SUBJECT MATTER

IPC: **A63B 21/00**(2006.01)
B62B 3/00(2006.01)

USPC: 482/51

According to International Patent Classification (IPC) or to both national classification and IPC

B. FIELDS SEARCHED

Minimum documentation searched (classification system followed by classification symbols)
 U.S. : 482/51

Documentation searched other than minimum documentation to the extent that such documents are included in the fields searched

Electronic data base consulted during the international search (name of data base and, where practicable, search terms used)

C. DOCUMENTS CONSIDERED TO BE RELEVANT

Category *	Citation of document, with indication, where appropriate, of the relevant passages	Relevant to claim No.
A	US 4,902,000 A (STARKS et al) 20 February 1990 (20.02.1990), see entire document.	1-38
A	US 5,520,597 A (TOBIN) 28 May 1996 (28.05.1996), see entire document.	1-38
A	US 5,380,262 A (AUSTIN) 10 January 1995 (10.01.1995), see entire document.	1-38

Further documents are listed in the continuation of Box C.

See patent family annex.

* Special categories of cited documents:

"A" document defining the general state of the art which is not considered to be of particular relevance

"E" earlier application or patent published on or after the international filing date

"L" document which may throw doubts on priority claim(s) or which is cited to establish the publication date of another citation or other special reason (as specified)

"O" document referring to an oral disclosure, use, exhibition or other means

"P" document published prior to the international filing date but later than the priority date claimed

"T" later document published after the international filing date or priority date and not in conflict with the application but cited to understand the principle or theory underlying the invention

"X" document of particular relevance; the claimed invention cannot be considered novel or cannot be considered to involve an inventive step when the document is taken alone

"Y" document of particular relevance; the claimed invention cannot be considered to involve an inventive step when the document is combined with one or more other such documents, such combination being obvious to a person skilled in the art

"&" document member of the same patent family

Date of the actual completion of the international search

18 August 2007 (18.08.2007)

Date of mailing of the international search report

03 OCT 2007

Name and mailing address of the ISA/US

Mail Stop PCT, Attn: ISA/US
 Commissioner for Patents
 P.O. Box 1450
 Alexandria, Virginia 22313-1450

Facsimile No. (571) 273-3201

Authorized officer

Glenn Richman

Telephone No. 571-272-4981

