

(19) World Intellectual Property Organization
International Bureau



(43) International Publication Date
19 November 2009 (19.11.2009)

(10) International Publication Number
WO 2009/140233 A2

- (51) International Patent Classification:
B63C 1/02 (2006.01) *G01C 9/00* (2006.01)
G05D 1/08 (2006.01) *B63B 43/06* (2006.01)
- (21) International Application Number:
PCT/US2009/043541
- (22) International Filing Date:
12 May 2009 (12.05.2009)
- (25) Filing Language: English
- (26) Publication Language: English
- (30) Priority Data:
61/052,603 12 May 2008 (12.05.2008) US
61/077,134 30 June 2008 (30.06.2008) US
12/464,055 11 May 2009 (11.05.2009) US
- (71) Applicants and
(72) Inventors: SMITH, David, Q. [US/US]; 1195 Mira Mar Dr., Vista, CA 92081 (US). LEVEZU, Alan, P. [US/US]; 950 Pine Hill Road, Colfax, CA 95713 (US).
- (74) Agent: VOLK, Michael, D.; Stoneman Volk Patent Group, 3770 N. 7th St., Suite 100, Phoenix, AZ 85014-5022 (US).
- (81) Designated States (unless otherwise indicated, for every kind of national protection available): AE, AG, AL, AM,

AO, AT, AU, AZ, BA, BB, BG, BH, BR, BW, BY, BZ, CA, CH, CN, CO, CR, CU, CZ, DE, DK, DM, DO, DZ, EC, EE, EG, ES, FI, GB, GD, GE, GH, GM, GT, HN, HR, HU, ID, IL, IN, IS, JP, KE, KG, KM, KN, KP, KR, KZ, LA, LC, LK, LR, LS, LT, LU, LY, MA, MD, ME, MG, MK, MN, MW, MX, MY, MZ, NA, NG, NI, NO, NZ, OM, PG, PH, PL, PT, RO, RS, RU, SC, SD, SE, SG, SK, SL, SM, ST, SV, SY, TJ, TM, TN, TR, TT, TZ, UA, UG, US, UZ, VC, VN, ZA, ZM, ZW.

(84) Designated States (unless otherwise indicated, for every kind of regional protection available): ARIPO (BW, GH, GM, KE, LS, MW, MZ, NA, SD, SL, SZ, TZ, UG, ZM, ZW), Eurasian (AM, AZ, BY, KG, KZ, MD, RU, TJ, TM), European (AT, BE, BG, CH, CY, CZ, DE, DK, EE, ES, FI, FR, GB, GR, HR, HU, IE, IS, IT, LT, LU, LV, MC, MK, MT, NL, NO, PL, PT, RO, SE, SI, SK, TR), OAPI (BF, BJ, CF, CG, CI, CM, GA, GN, GQ, GW, ML, MR, NE, SN, TD, TG).

Declarations under Rule 4.17:

— of inventorship (Rule 4.17(iv))

Published:

— without international search report and to be republished upon receipt of that report (Rule 48.2(g))

(54) Title: FLOATING DOCK DEFLECTION MANAGEMENT SYSTEMS

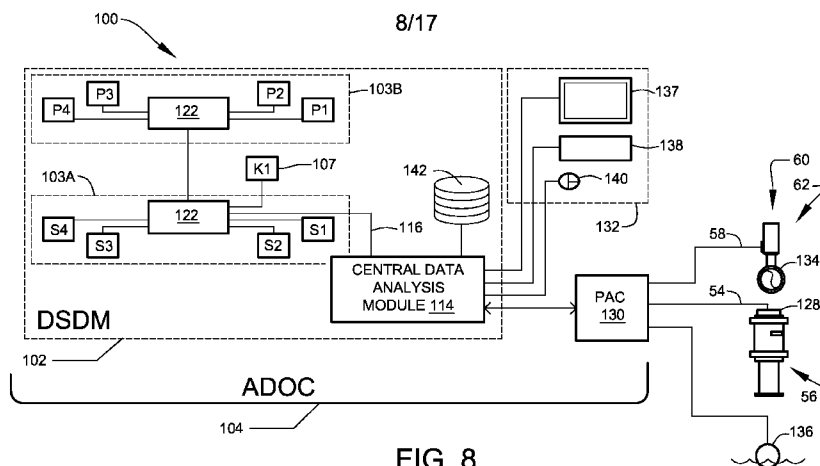

FIG. 8

(57) Abstract: This invention relates to a ready system for providing floating dock deflection management systems increasing operations efficiency and providing accurate, safe control to eliminate man-made accidents. This invention also relates to a ready system for providing floating dock deflection management systems providing information to safely operate at least one dry dock without over-stressing the metallurgy of the dry dock.

WO 2009/140233 A2

FLOATING DOCK DEFLECTION MANAGEMENT SYSTEMS**BACKGROUND**

This invention relates to improved floating dock deflection management systems. More particularly, this invention relates to a ready system for providing floating dock deflection management systems. Further, this invention relates to providing a ready system for floating dock deflection management systems increasing operations efficiency and providing accurate, safe control to eliminate man-made accidents. Additionally, this invention relates to a ready system for providing floating dock deflection management systems providing information to safely operate at least one dry dock without over-stressing the metallurgy of the dry dock.

Presently, floating dock deflection management systems do not comprise, for example, a system for precisely monitoring and controlling longitudinal deflection of at least one length of at least one dry dock, to levels of precision of the order of micro-radians. Also, presently, floating dock deflection management systems do not comprise, for example, a system for precisely monitoring and controlling transverse deflection of at least one length of at least one dry dock, to levels of precision of the order of micro-radians. Additionally, presently, floating dock deflection management systems do not comprise, for example, a system for precisely monitoring and controlling transverse longitudinal deflection or skew of at least one length of at least one dry dock, to levels of precision of the order of micro-radians

Thus, a need exists for a ready floating dock deflection management system that comprises, for example, monitoring and controlling longitudinal deflection, and/or monitoring and controlling transverse deflection, and/or monitoring and controlling transverse longitudinal deflection and/or skew of at least one length of at least one dry dock, to levels of precision of the order of micro-radians.

OBJECTS AND FEATURES OF THE INVENTION

A primary object and feature of the present invention is to provide floating dock deflection management systems that comprise monitoring and controlling longitudinal deflection of at least one length of at least one dry dock.

It is a further object and feature of the present invention to provide ready floating dock deflection management systems that comprise monitoring and controlling transverse deflection of at least one length of at least one dry dock, to levels of precision of the order of micro-radians

It is a further object and feature of the present invention to provide ready floating dock deflection management systems that comprise monitoring and controlling transverse longitudinal deflection or skew of at least one length of at least one dry dock, to levels of precision of the order of micro-radians

Also, a further primary object and feature of the present invention is to provide such a system that is efficient, inexpensive, and handy. Other objects and features of this invention will become apparent with reference to the following descriptions.

SUMMARY OF THE INVENTION

5 In accordance with a preferred embodiment hereof, this invention provides an apparatus, relating to controlling deflections of materials of at least one large, dynamically-supported, elongated floatable structure having a plurality of dynamic support points, comprising: at least one first set of sensors associated with such materials and respectively spaced at respective sensor locations along at least one first length of such materials substantially parallel to at least
10 one longitudinal axis of such structure; and at least one controller structured and arranged to take dynamic support action responsive to outputs of such at least one first set of sensors; wherein each respective sensor of such at least one first set of sensors is essentially adapted to measure respective relative inclination at a respective sensor location along such at least one first length of such materials; wherein each such sensor essentially provides information in relation to
15 relative inclinations in respective portions of such structure to such at least one controller; wherein such dynamic support action taken by such at least one controller comprises minimizing of such relative inclinations; and wherein deflections in such materials of such respective portions may be controlled; and at least one action system structured and arranged to perform such dynamic support action.

20 Moreover, it provides such a apparatus wherein: such at least one first length comprises at least one first sub-length and at least one second sub-length, each one oriented substantially parallel to the at least one longitudinal axis of such structure; such at least one first set of sensors comprises at least one first plurality of sensors and at least one second plurality of sensors; such at least one first plurality of sensors is associated with such materials and are spaced at
25 respective sensor locations along such at least one first sub-length; and such at least one second plurality of sensors is associated with such materials and are spaced at respective sensor locations along such at least one second sub-length. Additionally, it provides such a apparatus further comprising: at least one position sensor located midships of such elongated floatable structure; wherein such at least one position sensor essentially provides at least one reference
30 indicating position of such elongated floatable structure with respect to at least one horizon; and wherein such at least one action system, responsive to such at least one controller, essentially assists such structure to seek to remain in essentially a horizontal plane.

Also, it provides such an apparatus wherein: such at least one controller comprises at least one computer processor structured and arranged to respond to deflection information of such

sensors and control such action system to minimize any deflections. In addition, it provides such a apparatus wherein: such at least one action system further comprises at least one pumping-system interface structured and arranged to interface with at least one ballast pumping system of such elongated floatable structure; wherein such at least one ballast pumping system interface
5 assists pumping at least one flowable ballast substance; and such at least one pumping-system interface is further structured and arranged to respond to such at least one controller. And, it provides such a apparatus wherein: such at least one action system further comprises at least one plurality of ballast-tank sensors structured and arranged to respectively measure the flowable ballast substance contained within a plurality of ballast tanks of such elongated floatable
10 structure; and such at least one pumping-system interface is structured and arranged to assist move such flowable ballast substance in and out of selected ballast tanks among such at least one plurality of ballast tanks in accordance with control of such at least one controller. Further, it provides such a apparatus wherein: such at least one action system further comprises at least one ballast-valving interface structured and arranged to interface with at least one ballast-valving
15 system of such elongated floatable structure; such at least one ballast-valving interface is structured and arranged to respond to such at least one controller; and such at least one ballast-valving interface is further structured and arranged to selectively enable such at least one flowable ballast substance to selectively flow into or out of individual ballast tanks of such at least one plurality of ballast tanks.

20 Even further, it provides such a apparatus further comprising: at least one third plurality of sensors associated with such materials and respectively spaced at respective sensor locations along at least one transverse width of such materials substantially perpendicular to at least one longitudinal axis of such structure; wherein such at least one controller is structured and arranged to take dynamic support action responsive to outputs of such at least one third plurality of
25 sensors; wherein each respective sensor of such at least one third plurality of sensors is essentially structured and arranged to measure respective relative inclination at a respective sensor location along such at least one transverse width; wherein each such sensor of such at least one third plurality of sensors essentially provides information in relation to such transverse relative inclinations in respective portions of such structure to such at least one controller; and
30 wherein such dynamic support action by such at least one controller comprises minimizing of such transverse relative inclinations; wherein deflections in such materials of such transverse respective portions may be controlled; and wherein such at least one action system is structured and arranged to perform such transverse dynamic support action.

Moreover, it provides such a apparatus wherein: each such sensor of such at least one third plurality of sensors comprises at least one inclinometer sensor; and each such at least one inclinometer sensor comprises at least one inclination transducer adapted to provide at least one electrical output proportioned as to the angular variation from gravity vector. Additionally, it provides such a apparatus wherein essentially each of such first plurality of sensors, such second plurality of sensors, and such position sensor, is connected by at least one network protocol to such at least one control system. Also, it provides such a apparatus wherein: each such sensor of such at least one first plurality of sensors, such at least one second plurality of sensors, and such at least one position sensor comprises at least one inclinometer sensor; each such at least one inclinometer sensor comprises at least one inclination transducer adapted to provide at least one electrical output proportioned as to the angular variation from gravity vector; and such at least one electrical output substantially relates to at least one trim angle of such elongated floatable structure.

In addition, it provides such a apparatus wherein: each such at least one inclinometer sensor of such at least one first plurality of sensors, such at least one second plurality of sensors, and such at least one position sensor further comprise at least one inclination transducer structured and arranged to provide at least one electrical output proportioned as to the angular variation from gravity vector; and such at least one electrical output substantially relates to at least one roll (list angle) of such elongated floatable structure. And, it provides such a apparatus wherein: each such at least one inclinometer sensor of such at least one first plurality of sensors, such at least one second plurality of sensors, and such at least one position sensor further comprise at least one inclination transducer structured and arranged to provide at least one electrical output proportioned as to the angular variation from gravity vector; such at least one electrical output substantially relates to at least one trim angle and at least one list angle; and such at least one electrical output is substantially determined by variations of electrical resistance associated with at least one resistance bridge as such at least one resistance bridge experiences such at least one trim angle and such at least one list angle.

Further, it provides such a apparatus wherein: such at least one controller further comprises at least one sensor-signal collector circuit structured and arranged to attach to such at least one first plurality of sensors and such at least one second plurality of sensors and such at least one position sensor; and such at least one sensor-signal collector circuit provides at least one sensor-signal converter. Even further, it provides such an apparatus wherein such at least one sensor-signal converter converts at least one sensor analog signal to at least one digital signal. Moreover, it provides such an apparatus wherein such at least one sensor-signal collector circuit

provides at least one serial data stream to at least one network protocol data stream.

Additionally, it provides such an apparatus wherein such at least one network protocol comprises Ethernet protocol. Also, it provides such a apparatus wherein: such at least one controller further comprises at least one power supply structured and arranged to provide power to such at least
5 one first plurality of sensors and such at least one second plurality of sensors and such at least one position sensor; and such at least one power supply comprises at least one power circuit adapted to provide power to at least one power-over-Ethernet protocol switch. In addition, it provides such an apparatus further comprising such at least one floatable structure. And, it provides such an apparatus wherein: such at least one floatable structure comprises at least one
10 dry dock; and such flowable ballast substance comprises water upon which such at least one dry dock is afloat. Further, it provides such a apparatus wherein such at least one dry dock comprises: at least one starboard wing-wall extending substantially along such at least one first sub-length; at least one port wing-wall extending substantially along such at least one second sub-length; and at least one floor extending substantially between such at least one starboard
15 wing-wall and such at least one port wing-wall; wherein such first plurality of sensors is attached along such at least one starboard wing-wall; wherein such second plurality of sensors is attached along such at least one port wing-wall; and wherein such at least one position sensor is attached midships along such at least one floor.

In accordance with another preferred embodiment hereof, this invention provides a
20 retrofitting method, relating to providing enhanced control of deflections of materials in at least one large, dynamically-supported, elongated structure, wherein such structure comprises a first set of sensors spaced along a first length of such structure, such retrofitting method comprising the steps of: providing a second set of sensors to replace such first set of sensors; wherein essentially each of such second set of sensors comprises a more direct measurement of
25 inclination than essentially each of such first set of sensors; and installing such second set of sensors in such structure; wherein at least one existing controller for controlling such deflections, usable with such first set of sensors, in essentially unmodified form, is useable with such second set of sensors. Even further, it provides such a method wherein such step of installing such second set of sensors in such structure comprises the step of: decoupling such first set of sensors,
30 providing a measure of elevation, from such at least one existing controller; and operably coupling such second set of sensors, providing substantially a measure of inclination, with such at least one existing controller.

In accordance with another preferred embodiment hereof, this invention provides a method, relating to controlling deflections of materials of at least one large, dynamically-supported,

elongated floatable structure having a plurality of dynamic support points, comprising the steps of: installing at least one first set of sensors associated with such materials and respectively spaced at respective sensor locations along at least one first length of such materials substantially parallel to at least one longitudinal axis of such structure; and installing at least one controller adapted to take dynamic support action responsive to outputs of such at least one first plurality of sensors; installing at least one action system structured and arranged to perform such dynamic support action; wherein each respective sensor of such at least one first plurality of sensors is essentially adapted to measure respective relative inclination at a respective sensor location along such at least one first length of such materials; wherein such each such sensor essentially provides information in relation to relative inclinations in respective portions of such structure to such at least one controller; wherein such dynamic support action by such at least one controller comprises minimizing of such relative inclinations; and wherein deflections in such materials of such respective portions may be controlled. Moreover, it provides such a method further comprising the steps of: identifying within such at least one first length, at least one first sub-length and at least one second sub-length, each one oriented substantially parallel to at least one longitudinal axis of such structure; arranging such at least one first set of sensors to comprise at least one first plurality of sensors and at least one second plurality of sensors; spacing such at least one first set of sensors at respective sensor locations along such at least one first sub-length and associating such at least one first set of sensors with such materials of such at least one first sub-length; spacing such at least one second set of sensors at respective sensor locations along such at least one second sub-length and associating such at least one second set of sensors with such materials of such at least one second sub-length.

Additionally, it provides such a method further comprising the step of: providing at least one position sensor located midships of such elongated floatable structure; and operably coupling such at least one position sensor to such at least one controller to essentially provide at least one reference indicating position of such elongated floatable structure with respect to at least one horizon; wherein such at least one action system, responsive to such at least one controller, essentially assists such structure to seek to remain in essentially a horizontal plane. Also, it provides such a method further comprising the steps of: merging information from such at least one first plurality of sensors, such at least one second plurality of sensors, and such at least one position sensor within such at least one controller; determining at least one action by such at least one action system, using such merged data, to essentially assists such structure to seek to remain in such essentially a horizontal plane; and initiating by such at least one controller, such at least one action of such at least one action system. In addition, it provides such a method

further comprising the steps of: providing within such at least one action system, at least one ballast-pumping-system interface adapted to assist action-system controlled pumping of at least one flowable ballast substance by at least one ballast pumping system of such elongated floatable structure; providing within such at least one action system, at least one plurality of ballast-tank sensors structured and arranged to respectively measure the flowable ballast substance contained within a plurality of ballast tanks of such elongated floatable structure, wherein such at least one pumping-system interface is structured and arranged to assist move such flowable ballast substance in and out of selected ballast tanks among such at least one plurality of ballast tanks in accordance with control of such at least one controller; and providing within such at least one action system, at least one ballast-valving interface structured and arranged to interface with at least one ballast-valving system of such elongated floatable structure; wherein such at least one ballast-valving interface is structured and arranged to respond to such at least one controller; and wherein such at least one ballast-valving interface is further structured and arranged to selectively enable such at least one flowable ballast substance to selectively flow into or out of individual ballast tanks of such at least one plurality of ballast tanks.

And, it provides such a method further comprising the steps of: providing at least one third plurality of sensors associated with such materials and respectively spaced at respective sensor locations along at least one transverse width of such materials substantially perpendicular to at least one longitudinal axis of such structure; operably coupling outputs of such at least one third plurality of sensors with such at least one controller; wherein each respective sensor of such at least one third plurality of sensors is essentially adapted to measure respective relative inclination at a respective sensor location along such at least one transverse width; wherein each such sensor of such at least one third plurality of sensors essentially outputs information in relation to such transverse relative inclinations in respective portions of such structure to such at least one controller; wherein such dynamic support action by such at least one controller comprises minimizing of such transverse relative inclinations; wherein deflections in such materials of such transverse respective portions may be controlled; and wherein such at least one action system structured and arranged to perform such transverse dynamic support action.

Further, it provides such a method further comprising the step of connecting essentially each of such first plurality of sensors, such second plurality of sensors, and such position sensor to such at least one control system by at least one network having at least one network protocol. In accordance with another preferred embodiment hereof, this invention provides an apparatus, relating to monitoring deflections of materials of at least one large, floating, elongated dry dock, comprising: at least one first plurality of sensors associated with such materials and respectively

spaced at respective sensor locations along at least one first length of such materials substantially parallel to at least one longitudinal axis of such structure; and at least one monitor adapted to make indications responsive to outputs of such at least one first plurality of sensors; wherein each respective sensor of such at least one first plurality of sensors is essentially adapted to measure respective relative inclination at a respective sensor location along such at least one first length of such materials; wherein such each such sensor essentially provides information in relation to relative inclinations in respective portions of such structure to such at least one monitor; and wherein deflections in such materials of such respective portions may be monitored. In addition, this invention provides each and every novel feature, element, combination, step and/or method disclosed or suggested by this patent application.

BRIEF DESCRIPTION OF THE DRAWINGS

FIG. 1 shows an overall schematic diagram, illustrating a Digital Sensor Deflection Monitor adapted to monitor structural deflections within a large, dynamically-supported, elongated floatable structure, according to a preferred embodiment of the present invention.

FIG. 2 shows a schematic diagram, illustrating a preferred longitudinal distribution of sensor units within a floating dry dock, according to a preferred embodiment of the present invention.

FIG. 3 shows a schematic structural diagram, of preferred placements of sensor units within the floating dry dock, according to the preferred installation of FIG. 1.

FIG. 4 shows a diagrammatic illustration, of preferred circuiting arrangements of a single sensor unit, according to a preferred embodiment of the present invention.

FIG. 5 shows a schematic illustration, of simplified calculations for five digital inclinometer-based sensors mounted along a single wing wall of floating the dry dock, according to a preferred embodiment of the present invention.

FIG. 6 shows a schematic illustration, of simplified calculations for a single axis five digital inclinometer-based sensors mounted along a wing wall of a dry dock, according to a preferred embodiment of the present invention.

FIG. 7 shows a schematic illustration, of sensors are placed linearly along a calculated centerline and deflection measured at 3 selected points along a wing wall of the floating dry dock, according to a preferred embodiment of the present invention.

FIG. 8 shows an overall schematic diagram, illustrating an Automated Dock Operating Controller, according to a preferred embodiment of the present invention.

FIG. 9 shows a flow diagram depicting the preferred steps of a method of retrofitting large, dynamically-supported, elongated structures to provide enhanced control of deflections of materials, according to a preferred method of the present invention.

FIG. 10 shows a flow diagram depicting the preferred steps of a method of installing at least one of the preferred embodiments of the present invention within a large, dynamically-supported, elongated structure.

FIG. 11 shows a diagram illustrating a graphical user interface of the Automated Dock Operating Controller, graphically depicting the overall physical status of a monitored dry dock, according to the preferred embodiment of FIG. 8.

FIG. 12 shows a diagram illustrating a graphical user interface of the Automated Dock Operating Controller, depicting hog, sag, trim, heel, and trend data of the monitored dry dock, according to the preferred embodiment of FIG. 8.

FIG. 13 shows a diagram illustrating a graphical user interface of the Automated Dock Operating Controller, depicting a summary of list, trim, and deflection of the monitored dry dock, according to the preferred embodiment of FIG. 8.

FIG. 14 shows a diagram illustrating a graphical user interface of the Automated Dock Operating Controller, depicting longitudinal and transverse deflection of the monitored dry dock, according to the preferred embodiment of FIG. 8.

FIG. 15 shows a diagram illustrating a graphical user interface of the Automated Dock Operating Controller, depicting the status of the ballast tanks of the monitored dry dock, according to the preferred embodiment of FIG. 8.

FIG. 16 shows a diagram illustrating a graphical user interface of the Automated Dock Operating Controller, depicting the status of the ballast pumps of the monitored dry dock, according to the preferred embodiment of FIG. 8.

FIG. 17 shows a diagram illustrating a graphical user interface of the Automated Dock Operating Controller, depicting evolution historical draft trends of the monitored dry dock, according to the preferred embodiment of FIG. 8.

DETAILED DESCRIPTION OF THE BEST MODES AND PREFERRED EMBODIMENTS OF THE INVENTION

FIG. 1 shows an overall schematic diagram illustrating Digital Sensor Deflection Monitor **102** for substantially continuously measuring multiple types of structural deflections within a large, dynamically-supported, elongated floatable structure **50**. FIG. 2 shows a schematic diagram illustrating a preferred longitudinal distributed of sensor units within a floating dry dock **105**, according to a preferred embodiment of the present invention.

Digital Sensor Deflection Monitor **102**, hereinafter referred to as DSDM **102** preferably uses an arrangement of solid state sensor units **110** mounted at various monitoring points throughout the elongated floatable structure **50**. In a highly preferred application of the technology, DSDM **102** is preferably used to monitor structural deflections within floating dry dock **105**, as shown.

DSDM **102** is a preferred embodiment of floating dock deflection management system **100**, which preferably comprises additional preferred system embodiments, preferably including embodiments capable of overall automated operation and control. The key goals of the preferred embodiments of floating dock deflection management system **100** are to increase operations efficiency and to provide safe and accurate control of such large floatable structures.

Floating dry docks, such as floating dry dock **105**, are an important class of such large, dynamically-supported, elongated floatable structures. Floating dry docks are typically made of steel and have an arrangement of air-tight "ballast tanks" that allow the dry-dock to be submerged so that a ship or marine vessel can drive into it and then be picked up so that it is above the waterline, on a dry deck, for repair and/or maintenance. Simply stated, the ballast tanks are flooded with a flowable ballast substance (most preferably the seawater in which the dock resides) when the dock is lowered and that same ballast water is pumped out to lift the dock structure in the upward direction. This modulation of buoyancy must be carried out in a controlled manner to avoid failure of the dock structure.

Floating dry docks are inherently stiff and excessive stress (deflection) during operation can cause the vessel to break. Dry docks can become unsafe when operated poorly. Depending on the loading or unloading of the ballast tanks, the dry dock can bend. If bending tolerances of the materials are exceeded, the dry docks can suffer a catastrophic failure. This bending of the dry dock is known as deflection.

Floating dry dock **105** comprises a longitudinal axis **101** extending through the midline of the structure, as shown. A typical preferred configuration of floating dry dock **105** comprises a generally "U" shaped cross-section, as shown, the dock structure preferably comprising a dock floor **111** spanning between two wing walls **103**, as shown in FIG. 2. Wing walls **103** (inclusive of starboard wing wall **103A** and port wing wall **103B**) are preferably oriented generally parallel with the longitudinal axis **101** and extend continuously along a longitudinal length **L** of the dock, as shown. The dock floor **111** supports the weight of the dry-docked vessel and the wing walls **103** are used, in part, to give the floating dry dock **105** stability when dock floor **111** is submerged.

A preferred embodiment of DSDM **102** is adapted to function as a stand-alone monitoring system, preferably providing computer-assisted monitoring and reporting of a vessel's structural performance. Alternate preferred embodiments of DSDM **102** are adapted to be operable with one or more comprehensive dock operations and control systems, as generally
5 described in FIG. 8. The primary preferred function of DSDM **102** is to provide information to safely operate floating dry dock **105** without over-stressing the materials of the dock structure.

In the simplest preferred embodiment of DSDM **102**, measurements of the "hog" (upwards longitudinal deflection), and "sag" (downwards longitudinal deflection) are provided. In addition to the hog and sag readings, the basic system is preferably capable of providing
10 several types of bend, flex, stress, and angular information about the dock structure, which are not conventionally available to the operator of floating dry dock **105**. Also included in this preferred array of information is data that can be used to calculate strain within the wing walls **103** during haul-in and haul-out of the vessel to be repaired.

DSDM **102** is preferably organized around multiple sensor units **110**, central data
15 analysis module **114**, and one or more networked communication links **116** interconnecting the array of sensor units **110** to central data analysis module **114**, as shown. Central data analysis module **114** (at least embodying herein at least one controller) preferably comprises a computer processor that preferably creates a virtual "map" of the dry-dock structure using data from the plurality of sensor units **110**. The deflection (bend) within the structure of floating dry dock **105**
20 is preferably calculated by central data analysis module **114** to allow immediate determinations of structural status. Central data analysis module **114** is preferably adapted to communicate immediate and clearly-discernible indications of dock status, preferably responsive to the outputs of sensor units **110**. Preferred embodiments of central data analysis module **114** comprise one or more alarm features functioning to alert the dock operator of an approaching maximum structural
25 or positional limit, and to provide an alarm when such a limit has been exceeded.

As a stand-alone system DSDM **102** preferably provides monitoring data essential to safe, automated dock evolutions and dock operations. Preferably, central data analysis module **114** is scalable to expand the system's basic monitoring functions to include active control of the ballast control system **60** within floating dry dock **105** (as further described in FIG. 8). In this
30 alternate preferred embodiment of DSDM **102**, central data analysis module **114** is preferably configured to take dynamic support action responsive to outputs of sensor units **110**. More specifically, alternate preferred embodiments of DSDM **102** are preferably designed to provide essentially automatic deflection compensation by actively controlling the pumps, valves, and related components of ballast control system **60** (at least embodying herein wherein such at least

one controller is structured and arranged to take dynamic support action responsive to outputs of such at least one first set of sensors).

Each sensor unit **110** is preferably associated with materials within a discrete region of the structure. Each sensor unit **110** is essentially adapted to measure respective relative
5 inclination at a respective sensor location along the longitudinal length **L** the structure. A set of sensors units **110** (at least embodying herein at least one first set of sensors) are preferably mounted at measured locations along longitudinal length **L** of the structure, preferably along at least one of the two wing walls **103** (at least embodying herein wherein such at least one first set of sensors associated with such materials are respectively spaced at respective sensor locations
10 along at least one first length of such materials substantially parallel to at least one longitudinal axis of such structure). More preferably, sensors units **110** are mounted at measured locations along both of the two wing walls **103**, as shown. At least one additional sensor unit **110** (identified in FIG. 1 as sensor **K1** and central reference sensor **107** in FIG. 2) is preferably mounted adjacent longitudinal axis **101** (over the keel), preferably as close to the middle of the
15 dock as possible.

To monitor the structure of both wing walls **103**, the set of sensor units **110** are preferably arranged into a first plurality of sensor units, preferably identified as starboard sensor units **110A**, and a second plurality of sensor units identified as port sensor units **110B**. Starboard sensor units **110A** are preferably spaced at respective sensor locations along a first sub-length **L1**
20 of starboard wing wall **103A**, as shown. Port sensor units **110B** are preferably spaced at respective sensor locations along a second sub-length **L2** of port wing wall **103B**, as shown. Both first sub-length **L1** and second sub-length **L2** are preferably aligned substantially parallel to longitudinal axis **101**, as shown.

A typical installation of DSDM **102** will preferably includes additional starboard sensor
25 units **110A** and port sensor units **110B**, as generally necessitated by the wing wall length, organization of the underlying structures, etc. In general, monitoring by DSDM **102** is optimized by mounting a sensor unit **110** at the junction of every other ballast tank **109** (see FIG. 3) along each wing wall **103**. In floating dry docks having both an extended longitudinal length and proportionately large transverse width, additional lines of sensor units **110**, extending generally
30 perpendicular to longitudinal axis **101**, are preferably used to provide a third sensor array measuring transverse deflection across dock floor **111** (in the least embodying herein at least one third plurality of sensors associated with such materials and respectively spaced at respective sensor locations along at least one transverse width of such materials substantially perpendicular to at least one longitudinal axis of such structure).

A single central reference sensor **107** (position sensor K1) is preferably mounted midships (also known as amidships, which is defined as in or toward the part of a ship midway between bow and stern; or in or toward the middle), preferably along the keel line of floating dry dock **105**, preferably as close to the middle of the dock floor **111** as possible. Central reference sensor **107** (at least embodying herein at least one position sensor located midships of such elongated floatable structure), preferably provides important reference data required to complete the preferred deflection calculations performed by data analysis module **114**. More specifically, central reference sensor **107** essentially provides reference data indicating position of elongated floatable structure **50** with respect to the horizon. Central reference sensor **107** is preferably used to determine whether the overall front to the back tilt of floating dry dock **105** is the same as that calculated, or whether a portion of the dock is actually bending more than expected. When central reference sensor **107** is used, the actual deflection can be determined with great accuracy.

The sensing elements within sensor units **110** are preferably substantially electronic (with no moving parts). Each sensor unit **110** preferably comprises a small electronic inclinometer **112** (see FIG. 4), preferably comprising a very sensitive digital biaxial (dual axis) clinometer. Preferably, each electronic inclinometer **112** is designed to measure angular position, preferably rotation in two orthogonal vertical planes with respect to vertical gravity vector. A preferred electronic inclinometer apparatus suitable for use with sensor unit **110** includes Model 900 Biaxial Clinometers produced by Applied Geomechanics Inc. of Santa Cruz, California U.S.A. The Model 900 Biaxial Clinometers utilize a non-conductive vial partially filled with a conductive liquid. When the sensor is level, the fluid covers a plurality of internal electrodes to an equal depth. When the sensor tilts, the depth of the fluid over each electrode changes, altering the electrical resistance between matched pairs of electrodes. The onboard electronics of the sensor measure these changes, converting them to DC outputs proportional to the tilt angle (at least embodying herein at least one inclination transducer adapted to provide at least one electrical output proportioned as to the angular variation from gravity vector). Since the preferred electronic inclinometer **112** are not based on optical technology, DSDM **102** does not require line-of-sight or clear weather to operate.

The preferred electronic inclinometers **112** are extremely accurate sensors, capable of measuring within micro-radians across both axes. Utilizing the above-noted electronic inclinometers **112**, DSDM **102** is capable of providing readings that are accurate to about 2 millimeters over a 100-meter dock.

Preferably, each electronic inclinometer **112** is rigidly mounted within a protective enclosure housing **113**, which in turn is rigidly mounted to a structural member of floating dry dock **105**. This enables each electronic inclinometer **112** to move in concert with the underlying material of the structure (at least embodying herein wherein such at least one first set of sensors is associated with such materials).

Preferably, each sensor unit **110** provides the data analysis computer with two axes of measurement; the y-axis is longitudinal along the length of the dock (trim angle - from forward to aft) and the x-axis is measuring laterally across the dock (list angle - from port to starboard). Each sensor unit **110** positioned within the structure returns the list and trim angle at the specific point of attachment. Once mounted, each electronic inclinometer **112** returns a high precision reading of both list and trim angle at the mounting location. Preferably, for maximum system performance, one sensor unit **110** is preferably mounted at each supporting structural beam **52** separating ballast tanks **109** within wing walls **103**, as best illustrated in FIG. 3. If this preferred arrangement is not feasible, sensor units **110** are alternately preferably placed between every other ballast tank **109**. If this preferred arrangement is not feasible, sensor units **110** are alternately preferably mounted to a stable element as close to a supporting structural beam separating ballast tanks **109** as possible.

Preferably, sensor units **110** are securely mounted onto the structural beams such that their respective enclosure housings **113** are mounted substantially level (preferably within about 2 degrees) in relation to each other and to the normal zero position of the keel of floating dry dock **105**. In a preferred method of mounting, one side of closure housing is aligned with the keel of floating dry dock **105** before being surface mounted to the structural member. Enclosure housing **113** preferably comprises a surface mounted NEMA-type metal enclosure, preferably rated for use in harsh environments.

FIG. 4 shows a diagrammatic illustration of preferred circuiting arrangements of a single sensor unit **110**, including circuiting supporting network communication link **116** with central data analysis module **114**. Preferably, the analog voltage output from electronic inclinometer **112** is applied to at least one sensor-signal converter circuit, preferably comprising analog-to-digital converter (ADC) **118**, as shown. Preferably, ADC **118** converts the analog signal to a digital representation. ADC **118** preferably comprises a minimum 8-bit resolution producing an RS-232 (Recommended Standard 232) serial binary data signal. The circuit may preferably comprise secondary support circuits, of types well known to those of ordinary skill in the art, such as reference voltage circuits, signal filtering circuits, buffering circuits, etc., as may be required to support the analog to digital conversion process.

The serial data output from ADC **118** is subsequently conformed to at least one standard network communication protocol. In a highly preferred embodiment, Ethernet communication protocol is utilized. Sensor unit **110** preferably comprises network interface hardware **120** allowing the serial data stream from ADC **118** to be transmitted to central data analysis module **114** via networked communication link **116**, as shown. Network interface **120** preferably comprises at least one RS232 to Ethernet interface device. Networked communication link **116** preferably implements the Internet protocol suite (commonly referred to as TCP/IP), preferably utilizing fixed IP (Internet Protocol) addresses for all network devices; thus, it is preferred that each network interface **120** be structured and arranged to support a fixed IP address for its respective sensor unit **110**. It is noted that preferred embodiments of sensor unit **110** combine ADC **118** and network interface **120** into a single unified device.

The preferred architecture of networked communication link **116** preferably comprises industry standard 10BaseT Ethernet, preferably using standard Category 5 or alternately preferably Category 6 wire throughout. In a preferred network organization, the network connections for individual sensor units **110** are routed to an intermediate network collector node **122** located centrally within respective wing walls **103**, as shown. Each network collector node **122** preferably comprises an Ethernet switch, most preferably, at least one power-over-Ethernet protocol switch, preferably adapted to provide operating electrical power to the plurality of distal sensor units **110** (at least embodying herein at least one power-over-Ethernet protocol switch structured and arranged to provide electrical power to such at least one first plurality of inclinometer sensors and such at least one second plurality of inclinometer sensors and such at least one position inclinometer sensor). Each network collector node **122** is preferably of a type hardened for industrial applications.

Network communication link **116** preferably comprises a dedicated local network (having no external links); however, one advantage provided by the preferred use of standard network protocols is the ability to inexpensively retrofit existing vessels by utilizing existing network infrastructure. For example, a preferred installation may preferably utilize an existing Ethernet-based camera system or equivalent data network. Upon reading the teachings of this specification, those of ordinary skill in the art will now understand that, under appropriate circumstances, considering such issues as user preference, intended use, etc., other hardware/software arrangements, such as the use of additional network interfaces, multiple redundant network configurations, access to an external enterprise system of the dock's owner/operator, internet connections supporting remote monitoring or data logging, etc., may suffice.

Preferably, network communication link **116** enables the acquisition of sensor data from the plurality of sensor units **110** by central data analysis module **114** in “real time” (at least embodying herein wherein such at least one controller further comprises at least one sensor-signal collector circuit adapted to attach to such at least one first plurality of inclinometer sensors and such at least one second plurality of inclinometer sensors and such at least one position inclinometer sensor). Preferably, central data analysis module **114** compares the list angle and trim angle information from each of sensor units **110** and uses geometrical algorithms to create a virtual “map” of the wing walls **103**, which closely matches the current state of the sensors and underlying structure of the dock. The deflection (bend) of the sections of floating dry dock **105** between sensor units **110** can be extrapolated by these calculations essentially in “real time”. Preferably, the overall shape of the monitored wing walls **103**, and physical location of any position along the wing walls **103** (relative to any other) is determined by central data analysis module **114** using such mathematical algorithms.

FIG. 5 shows a schematic illustration, of simplified calculations for five digital inclinometer-based sensors mounted along a single wing wall **103** of floating dry dock **105**, according to a preferred embodiment of the present invention. FIG. 5 shows only simplified (and much exaggerated) calculations derived from data associated with a single line of 5 sensor units **110** mounted axially along wing wall **103**. It is noted that, with data from additional sensor units **110** located within both wing walls **103** and data from a central reference sensor **107** located in the approximate center of the dock, the calculations and resulting map will be substantially more complex than is shown in FIG. 5.

FIG. 6 shows a schematic illustration, of calculations derived from a similar plurality of sensor units **110**, which are placed linearly along a calculated centerline, with deflection measured at three standard-points **A, B, C** along a single wing wall **103** of floating dry dock **105**, according to a preferred embodiment of the present invention. In this example, data from central reference sensor **107** (associated with the substantially horizontal baseline **115**) is preferably used to determine whether the overall tilt of dry dock **100** is the same as that calculated from the front to the back, or whether a portion of the dock is actually bending more than expected.

FIG. 7 shows a second simplified and overtly exaggerated graphical representation of the preferred calculations used in FIG. 6. Preferably, the preferred calculations are then referenced to central reference sensor **107** (baseline **115**) and split along the selected points for legacy reporting, as shown. In addition to the legacy data, additional information (such as “point of greatest deflection”) is generated and reported. With the precision level of the preferred electronic inclinometers **112**, the deflection distance accuracy at midpoint between two sensor

units **110** mounted about 20 meters apart is theoretically about 0.05 millimeters. In actual use, sensor units **110** are damped to provide readings accurate to about 1 millimeter over that distance. DSDM **102** preferably provides information which is arranged into overall, wing-wall specific, and cross section specific groupings. The following is a partial list of preferred data items available in essentially "real time" from DSDM **102**.

Dock Overall Deflection Information:

- Trim and List
- Tilt Direction and Angle
- 10 • Longitudinal Deflection (Hog/Sag)
- Longitudinal & Transverse Skew (Twist)
- Longitudinal Linearity
- Transverse Deflection (wall toe-in/out)
- Transverse Squareness (wall/keel trim)

15

Wing Wall specific Information:

- Wall Trim
- Wall Deflection and Skew
- Sectional Deflection
- 20 • Greatest Deflection Point
- Longitudinal Deflection (Hog/Sag)

Cross Section (Fwd/Mid/Aft) Information:

- Sectional List
- 25 • Transverse Deflection
- Transverse Skew
- Transverse Squareness

Real time deflection monitoring within DSDM **102** is preferably implemented by executing one or more monitoring programs within a physical processor of central data analysis module **114**. Central data analysis module **114** preferably comprises at least one general purpose computer platform. Preferably, the computer contains a central processing unit (CPU) and associated circuitry, memory, and a variety of input/output (I/O) devices to provide a communication interface with network communication link **116**, as shown. Alternate preferred

embodiments of central data analysis module **114** comprise at least one computer/user interface to allow for user interaction. Such I/O devices preferably comprise devices of the sort well known in the art. For example, preferred embodiments of central data analysis module **114** preferably comprise a display screen or monitor, keyboard, mouse, etc. Preferably, the memory stores monitoring program (or programs) of DSDM **102** that are executed to enable the preferred monitoring methods and processes described herein. Preferably, when the preferred computing platform of DSDM **102** executes such a program, it becomes a special-purpose device and thus an integral portion of DSDM **102**. Upon reading the teachings of this specification, those of ordinary skill in the art will now understand that, under appropriate circumstances, considering such issues as user preference, intended use, etc., other hardware/software arrangements, such as the use of additional network interfaces, wireless network communication, network firewalls, internet connections, security encryptions, data-logging capabilities, etc., may suffice.

Central data analysis module **114** is preferably adapted to communicate immediate and clearly-discernible indications of dock status, preferably responsive to the outputs of sensor units **110**. Preferred embodiments of central data analysis module **114** comprise one or more alarm features functioning to alert the dock operator of an approaching maximum structural or positional limit, and to provide an alarm when such a limit has been exceeded.

As a stand-alone system DSDM **102** preferably provides monitoring data essential to safe, automated dock evolutions and dock operations. Preferably, central data analysis module **114** is scalable to expand the system's basic monitoring functions to include full dock operations and control capabilities, as described in FIG. 8.

FIG. 8 shows an overall schematic diagram illustrating Automated Dock Operating Controller **104**, hereinafter referred to as ADOC **104**, according to a preferred embodiment of the present invention. ADOC **104** preferably expands the inclinometer-based monitoring of DSDM **102** to include automated dock operations and control functions. ADOC **104** preferably provides automated ballast control and deflection compensation, within floating dry dock **105**, including during dock sinking or raising (evolution) operations. ADOC **104** preferably takes dynamic support action to minimize relative inclinations within the dry dock structure (at least embodying herein wherein such dynamic support action by such at least one controller comprises minimizing of such relative inclinations). Such preferred dynamic action preferably includes actuation of valves **134** and ballast pumps **128** to fill and evacuate ballast tanks **109**, as described below.

ADOC **104** comprises, in addition to the hardware of DSDM **102**, proprietary Supervisory Control and Data Acquisition (SCADA) software **142**, Programmable Automation

Controller (PAC) **130** and supervisory control interface **132**, as shown. PAC **130** preferably provides input/output apparatus supporting both data acquisition and hardware control of critical field devices of floating dry dock **105**. Such data acquisition and hardware controls preferably include monitoring and control of ballast pumps **128**, feedback and actuators for tank valves **134**,
5 ballast tank level sensors **136**, etc. More specifically, PAC **130** (at least embodying herein at least one action system structured and arranged to perform such dynamic support action) preferably comprises pumping-system interface **54** to interface with ballast pumping system **56** of floating dry dock **105**, ballast-valving interface **58** to interface with ballast-valving system **62** of floating dry dock **105**, and a plurality of ballast tank level sensors **136** to measure the ballast
10 liquid contained within respective ballast tanks **109** of floating dry dock **105**. In addition, PAC **130** may preferably comprise a plurality of tank pressure sensors to monitor the pressure within individual ballast tanks **109**.

Pumping-system interface **54** is preferably configured to assist the controlled pumping the flowable ballast substance (seawater) by ballast pumps **128**. In a preferred arrangement of
15 the system, pumping-system interface **54** is operably coupled to the relay outputs of ballast pumps **128**. Ballast-valving interface **58** enables the seawater to be selectively directed into or out of individual ballast tanks **109**. In a preferred arrangement of the system, ballast-valving interface **58** is preferably coupled to the valve actuators and feedback circuits of ballast-valving system **62**. The plurality of ballast tank level sensors **136** is structured and arranged to assist
20 monitoring of the movement of the seawater in and out of selected ballast tanks **109** among the plurality of ballast tanks **109**. Upon reading this specification, those with ordinary skill in the art will now appreciate that, under appropriate circumstances, considering such issues as cost, user preference, etc., other sensor/control arrangements such as, for example, pump temperature sensors, line-pressure sensors, redundant sensor arrays, automatic shutdown apparatus, remote
25 alarm apparatus etc., may suffice.

Supervisory control interface **132** preferably expands central data analysis module **114** to include a full user interface, preferably comprising display screen or monitor **137**, keyboard **138**, mouse **140**, etc. In a preferred embodiment of supervisory control interface **132**, monitor **137** comprises at least one 20" LCD Display for maximum operator efficiency. Supervisory control
30 interface **132** is preferably adapted to allow the operator to enable or disable alarms, ballast control, etc., even when floating dry dock **105** is not transferring.

ADOC **104** preferably operates under proprietary Supervisory Control and Data Acquisition (SCADA) software **142**. Such software preferably runs on central data analysis module **114**. PAC **130** is preferably integrated with central data analysis module **114** such that

operational data generated by SCADA software **142** is passed to hardware-specific software running within PAC **130**. Using PAC **130**, ADOC **104** is preferably able to implement the necessary adjustments required to safely and accurately raise or lower floating dry dock **105** (at least embodying herein wherein such at least one controller comprises at least one computer processor structured and arranged to respond to deflection information of such sensors and control such action system to minimize any deflections; wherein each such sensor essentially provides information in relation to relative inclinations in respective portions of such structure to such at least one controller; wherein such dynamic support action taken by such at least one controller comprises minimizing of such relative inclinations; and wherein deflections in such materials of such respective portions may be controlled).

Preferably, SCADA software **142** operates within at least one computer operating system software environment, preferably a Microsoft Windows platform. The software graphical user interface of SCADA software **142** is preferably adapted to be intuitive and easy to operate, as generally illustrated in the graphical user interface diagrams of FIG. 11 through FIG. 17. The operator needs only to understand the purpose and function of the dock itself to operate ADOC **104**.

SCADA software **142** enables central data analysis module **114** to compare the list and trim information from each of sensor units **110** to create a virtual “map” of the wing walls **103** that closely matches the current state of the structures. The deflection (bend) of the sections of floating dry dock **105** between sensor units **110** can be extrapolated by these calculations essentially in “real time”. Preferably, the overall shape of the monitored wing walls **103** and physical location of any position along the wing walls **103** (relative to any other) is determined by central data analysis module **114** using mathematical algorithms. SCADA software **142** preferably gathers and processes the incoming sensor data for relative inclinations in respective portions of the structure (at least embodying herein wherein each such sensor essentially provides information in relation to relative inclinations in respective portions of such structure to such at least one controller; wherein such dynamic support action taken by such at least one controller comprises minimizing of such relative inclinations; and wherein deflections in such materials of such respective portions may be controlled). SCADA software **142** is preferably adapted to filter the incoming sensor data to accommodate normal pitch and roll experienced by the dry dock due to wave action.

Preferably, ADOC **104** comprises a built-in, multi-level, security preferably comprising individual user IDs and passwords. Users can preferably be assigned abilities ranging from

monitoring only to operational control, to full developmental capabilities, depending on the security requirements of the intended application.

Preferably, ADOC **104** substantially continuously monitors the status of floating dry dock **105**. ADOC **104** is preferably capable of performing system event logging. Preferably, during a raising or lowering transition all statuses and raw data values are preferably logged to allow review of any parameter for historical or maintenance purposes. This information is preferably saved into a standard format capable of being accessed not only through central data analysis module **114**, but also through outputs of a standard spreadsheet program.

ADOC **104** is preferably designed with safety as a primary goal. This is preferably accomplished through at least one checklist procedure coded within SCADA software **142**. Preferably, the checklist procedure requires a dock master to enter all pertinent vessel data, and the operator to verify operational status of important essential pieces of equipment prior to any raise/lower transition. Preferably, all of the system information must be entered and checked, before the operator can start the event. In order to begin an automated transition (raising or lowering the dock) the operator is preferably required by SCADA software **142** to enter data relating to the current dock configuration. If the checklist is not complete, the dock control system will not run.

ADOC **104** is preferably designed to monitor the status of a transition and react preemptively to any value that is moving in an off-specification direction. In addition, the alarming functionality is preferably designed to warn the operator of any item that is potentially a problem and can preferably suggest appropriate operational responses.

ADOC **104** is preferably designed to operate safely even if a portion of the plurality of sensor units **110** fails (preferably through the use of predictive control sequences and algorithms). Preferably, if needed, the operator can choose to disable the automatic control of ADOC **104** and manually operate all pumps and valves within the control of ADOC **104**. This preferred level of flexibility provides a back-up should a catastrophic event occur. If the operator chooses to do so, he or she can preferably disable the automatic controls of the dry dock, and manually control individual or all of the pumps and valves through one or more of the graphical interfaces depicted in FIG. 11 through FIG. 17. Once a valve has been selected, the operator can preferably input a value of 0% to 100% into the value indicator window, and ballast-valving interface **58** will adjust valve will move to that position. To turn on and off a ballast pump **128**, the operator can select the pump he/she wishes to manually control, and then with the mouse, click into the On/Off field.

ADOC **104** is preferably designed to fully employ system redundancy. Preferred subsystems ranging from operator interface computer of central data analysis module **114**, through the industrial logic controllers of PAC **130**, to sensors units **110**, and substantially all other intermediate subcomponents can be operated in a redundant fashion. Preferred

5 embodiments of ADOC **104** further comprise a redundant operator Interface structured and arranged to provide a second supervisory control interface **132** with substantially the same information and screens as the primary unit, thus allowing substantially greater flexibility for the operator. In addition, any operator display can preferably be selected as the primary for the purposes of data archival.

10 FIG. 9 shows a flow diagram depicting the preferred steps of method **200** for the retrofitting of large, dynamically-supported, elongated structures **50** to provide enhanced control of deflections of materials, according to a preferred method of floating dock deflection management system **100**. Preferably, the majority of the hardware within DSDM **102** is

15 designed to interface to most existing (conventional) dock controls of floating dry dock **105**. In the preferred steps of method **200** of the present invention, a first set of existing sensors (such as elevation-based sensors) are preferably decommissioned and replaced with small electronic inclinometer **112** (at least embodying herein providing a second set of sensors to replace such

20 first set of sensors wherein essentially each of such second set of sensors comprises a more direct measurement of inclination than essentially each of such first set of sensors). Preferably, the plurality of electronic inclinometers **112** are aligned with the existing controls, either through analog data connections, or digital data connections, as appropriate. In preferred retrofit

25 installations of method **200**, electronic inclinometers **112** preferably comprise subcomponents of the above-described sensory units **110**. The versatility of such sensory units **110** allows existing controllers to be used for monitoring or control of deflection, in essentially an unmodified form.

Thus, in accordance with method **200**, there is an initial preferred step **202** of providing a set of replacement electronic inclinometers **112** to replace the above-noted existing first set of sensors, wherein essentially each of the electronic inclinometers **112** (see FIG. 4) preferably

30 comprises a very sensitive digital biaxial (dual axis) clinometer to provide a more direct measurement of inclination than essentially each of the original sensors. In subsequent preferred step **204**, the set of replacement sensor units **110** are installed within the dock structure. In preferred step **204**, the original sensors may be decommissioned and abandoned in place or completely removed prior to the new installation. Next, as indicated in preferred step **206**, the electronic inclinometers **112** are operably coupled to an existing controller of the dock. Upon reading this specification, those with ordinary skill in the art will now appreciate that, under

appropriate circumstances, considering such issues as dock configuration, data interface, etc., other retrofitting arrangements such as, for example, providing dock specific mounting devices, new electrical wiring, new data-network infrastructure , etc., may suffice.

FIG. 10 shows a flow diagram depicting the preferred steps of method **300** of installing at least one of the above-described preferred embodiments of the present invention within a large, dynamically-supported, elongated structure **50**. In the initial preferred step **302** of method **300**, at least one first set of sensor units **110** is associated with the structural materials of the dock by mounting individual sensor units along the length of the structure. Next, at least one controller (ADOC **104**), adapted to take dynamic support action responsive to outputs of sensor units **110**, is preferably installed within elongated floatable structure **50**, as indicated in preferred step **304**. Next, at least one action system (PAC **130**) structured and arranged to perform such dynamic support action is preferably installed within elongated floatable structure **50**, as indicated in preferred step **306**.

In addition, method **300** preferably comprises the preferred step **308** of identifying within the overall length of elongated floatable structure **50**, at least one first sub-length **L1** and at least one second sub-length **L2**, preferably associated with starboard wing wall **103A** and port wing wall **103B** respectively. Within step **308**, the first set of sensor units **110** are preferably distributed between starboard wing wall **103A** and port wing wall **103B** to form a first plurality of sensors and a second plurality of sensors. Next, as indicated in preferred step **310**, at least one position sensor (central reference sensor **107**) is preferably located midships of elongated floatable structure **50** and coupled to ADOC **104**. Next, as indicated in preferred step **312**, information from sensor units **110**, including central reference sensor **107**, are preferably merged at central data analysis module **114** of ADOC **104**. ADOC **104** preferably uses the sensor data to determine at least one action, implemented by PAC **130**, to essentially assist the dock structure to seek to remain in such essentially a horizontal plane.

In addition, method **300** preferably comprises the preferred step **314** of providing within PAC **130**, pumping-system interface **54**, ballast-valving interface **58**, and ballast tank level sensors **136**. In addition, method **300** preferably comprises the preferred step **316** of connecting essentially each sensor unit **110** to ADOC **104** using at least one network having at least one network protocol.

FIG. 11 shows a diagram illustrating graphical user interface **400** of ADOC **104**, graphically depicting the overall physical status of a monitored floating dry dock **105**, according to the preferred embodiment of FIG. 8. The software graphical user interface of SCADA software **142** is preferably accessed through supervisory control interface **132**, preferably

comprising monitor **137**, keyboard **138**, mouse **140**, etc., as shown in FIG. 8. Graphical user interface **400** is preferably displayed on monitor **137**, or similar display device. The basic graphical user interface **400** is preferably divided into checklist window **402**, draft/valve/tanks/pump status window **404**, small hog/sag/trim/heel status window **406**, and menu bar **408**, as shown. Graphical user interface **400** preferably allows the operator to access any of the information that is required (at any time) using menu bar **408**, along the bottom of the screen. The screens of graphical user interface **400** are preferably displayed in a single window format or a split window format. Pop-up windows are also preferably used as needed.

Small hog/sag/trim/heel status window **406** preferably allows the operator to view the same information that is available on the main Hog, Sag, Heel, and Trim graphic overview screen of FIG. 12, in a smaller format, while viewing other screens during the operation of floating dry dock **105**.

Menu bar **408** is preferably divided into individual buttons used to access security windows, drafts visual windows, tanks visual windows, valves visual windows, pumps windows, manual control windows, set-point windows, history log windows, prints the active screen function, and a return to the main dock control screen of FIG. 11. The security screen is used to log users in and out of the system. Names and encrypted passwords are stored in a text file located on the hard drive of central data analysis module **114**. All “Log-On” and “Log-Off” activities are preferably recorded in a historical event data log.

FIG. 12 shows a diagram illustrating a graphical user interface **402** of ADOC **104**, graphically depicting hog, sag, trim, heel, and trend data of the monitored dry dock, according to the preferred embodiment of FIG. 8. This window preferably shows data assisting the operator monitor the status of the dock structures during the raising or lowering of the dock. This window is typically used while the drydock transfer operation is in progress. Hog/Sag Indicators preferably show the current Hog or Sag values for each side of the dock. The color of the text (Green or Red) is preferably used to indicate whether the values are within determined tolerances. A Hog / Sag display show the Hog and Sag (exaggerated for viewing) in a graphical format. Like the value indicators above them, the text preferably changes color based on the alarm status. A draft Indicator preferably indicates the average draft of the dock based on the six draft sensors. A trim display preferably indicates, both graphically and textually, the current trim of the dock. In addition, the angle of trim (degrees) is shown with the setpoint (target) trim that is set prior to a docking event. A heel display preferably displays the heel of the dock in both graphical and textual formats.

FIG. 13 shows a diagram illustrating graphical user interface **404** of ADOC **104**, depicting a summary of list, trim, and deflection of the monitored dry dock, according to the preferred embodiment of FIG. 8. Graphical user interface **404** preferably displays the list, trim, and deflection data in both graphical and textual formats, as shown. FIG. 14 shows a diagram illustrating graphical user interface **406** of ADOC **104**, depicting longitudinal and transverse deflection of the monitored dry dock, according to the preferred embodiment of FIG. 8. Graphical user interface **406** preferably displays the longitudinal and transverse deflection data in both graphical and textual formats, as shown.

FIG. 15 shows a diagram illustrating graphical user interface **408** of ADOC **104**, depicting the status of ballast tanks **109** of the monitored dry dock, according to the preferred embodiment of FIG. 8. This screen gives the operator three pieces of information related to each of the ballast tanks **109** by ballast tank level sensors **136**. A “mag. value” is preferably displayed reflecting filtered readings from each of the magnetic level sensors (ballast tank level sensors **136**) located inside each of the dry dock ballast tanks. A “pressure value” reading preferably displays filtered readings from each of the pressure level sensors located inside each of the dry dock tanks. A “working values” reading is also displayed and normally matches the mag. and pressure sensor values. Each ballast tank **109** in the dry dock is preferably represented as a rectangle display, and is labeled to match the dry docks tank layout.

FIG. 16 shows a diagram illustrating graphical user interface **410** of ADOC **104**, depicting the status of ballast pumps **128** of the monitored dry dock, according to the preferred embodiment of FIG. 8. FIG. 17 shows a diagram illustrating graphical user interface **412** of ADOC **104**, depicting evolution historical draft trends of the monitored dry dock, according to the preferred embodiment of FIG. 8. All events in the system are preferably logged to a file on the supervisory computer for later review. Such events preferably include any item that would typically have a specific time-stamp associated with the event. Preferred events for logging include operator log in/out, alarms, and transition specific events. All continuous data is preferably logged to a historical database and can be examined or displayed in the event a transition requires subsequent review (for example, mechanical failures such as pumps, motors, tank level indicators, etc.). Historical information is preferably presented in a graphical format, as shown, which allows for fast retrieval based on the date of the event. Preferably, when pertinent information is found, it can be printed or be transferred electronically. In addition, the information is preferably made available in a simple CSV format for easy import into most spreadsheet and database programs.

Although applicant has described applicant's preferred embodiments of this invention, it will be understood that the broadest scope of this invention includes modifications such as diverse shapes, sizes, and materials. Such scope is limited only by the below claims as read in connection with the above specification. Further, many other advantages of applicant's invention

5 will be apparent to those skilled in the art from the above descriptions and the below claims.

What is claimed is:

- 1) An apparatus, relating to controlling deflections of materials of at least one large, dynamically-supported, elongated floatable structure having a plurality of dynamic support points, comprising:
 - 5 a) at least one first set of sensors associated with such materials and respectively spaced at respective sensor locations along at least one first length of such materials substantially parallel to at least one longitudinal axis of such structure;
 - b) at least one controller structured and arranged to take dynamic support action responsive to outputs of said at least one first set of sensors; and
 - 10 c) at least one action system structured and arranged to perform such dynamic support action;
 - d) wherein each respective sensor of said at least one first set of sensors is essentially adapted to measure respective relative inclination at a respective sensor location along such at least one first length of such materials;
 - 15 e) wherein each said sensor essentially provides information in relation to relative inclinations in respective portions of such structure to said at least one controller;
 - f) wherein such dynamic support action taken by said at least one controller comprises minimizing of such relative inclinations; and
 - g) wherein deflections in such materials of such respective portions may be controlled.
- 20 2) The apparatus according to Claim 1 wherein:
 - a) such at least one first length comprises at least one first sub-length and at least one second sub-length, each one oriented substantially parallel to the at least one longitudinal axis of such structure;
 - 25 b) said at least one first set of sensors comprises at least one first plurality of sensors and at least one second plurality of sensors;
 - c) said at least one first plurality of sensors is associated with such materials and are spaced at respective sensor locations along such at least one first sub-length; and
 - d) such at least one second plurality of sensors is associated with such materials and are spaced at respective sensor locations along such at least one second sub-length.
- 30 3) The apparatus according to Claim 2 further comprising:
 - a) at least one position sensor located midships of such elongated floatable structure;

- b) wherein said at least one position sensor essentially provides at least one reference indicating position of such elongated floatable structure with respect to at least one horizon; and
- c) wherein said at least one action system, responsive to said at least one controller, essentially assists such structure to seek to remain in essentially a horizontal plane.
- 5
- 4) The apparatus according to Claim 3 wherein:
- a) said at least one controller comprises at least one computer processor structured and arranged to respond to deflection information of said sensors and control said action system to minimize any deflections.
- 10
- 5) The apparatus according to Claim 4 wherein:
- a) said at least one action system further comprises at least one pumping-system interface structured and arranged to interface with at least one ballast pumping system of such elongated floatable structure;
- 15
- b) wherein said at least one ballast pumping system interface assists pumping at least one flowable ballast substance; and
- c) said at least one pumping-system interface is further structured and arranged to respond to such at least one controller.
- 6) The apparatus according to Claim 5 wherein:
- 20
- a) said at least one action system further comprises at least one plurality of ballast-tank sensors structured and arranged to respectively measure the flowable substance contained within a plurality of ballast tanks of such elongated floatable structure; and
- b) said at least one plurality of ballast-tank sensors is structured and arranged to assist monitoring of such flowable ballast substance in and out of selected ballast tanks among such at least one plurality of ballast tanks.
- 25
- 7) The apparatus according to Claim 6 wherein:
- a) said at least one action system further comprises at least one ballast-valving interface structured and arranged to interface with at least one ballast-valving system of such elongated floatable structure;
- 30
- b) said at least one ballast-valving interface is structured and arranged to respond to such at least one controller; and

- c) said at least one ballast-valving interface is further structured and arranged to selectively enable such at least one flowable ballast substance to selectively flow into or out of individual ballast tanks of such at least one plurality of ballast tanks.
- 8) The apparatus according to Claim 7 further comprising:
- 5 a) at least one third plurality of sensors associated with such materials and respectively spaced at respective sensor locations along at least one transverse width of such materials substantially perpendicular to at least one longitudinal axis of such structure;
- 10 b) wherein said at least one controller is structured and arranged to take dynamic support action responsive to outputs of said at least one third plurality of sensors;
- c) wherein each respective sensor of said at least one third plurality of sensors is essentially structured and arranged to measure respective relative inclination at a respective sensor location along such at least one transverse width;
- 15 d) wherein each such sensor of said at least one third plurality of sensors essentially provides information in relation to such transverse relative inclinations in respective portions of such structure to said at least one controller; and
- e) wherein such dynamic support action by said at least one controller comprises minimizing of such transverse relative inclinations;
- 20 f) wherein deflections in such materials of such transverse respective portions may be controlled; and
- g) wherein said at least one action system is structured and arranged to perform such transverse dynamic support action.
- 9) The apparatus according to Claim 8 wherein:
- 25 a) each said sensor of said at least one third plurality of sensors comprises at least one inclinometer sensor; and
- b) each said at least one inclinometer sensor comprises at least one inclination transducer adapted to provide at least one electrical output proportioned as to the angular variation from gravity vector.
- 10) The apparatus according to Claim 7 wherein essentially each of said first plurality of sensors, said second plurality of sensors, and said position sensor, is connected by at least one network protocol to said at least one control system.
- 30 11) The apparatus according to Claim 10 wherein:

- a) each said sensor of said at least one first plurality of sensors, said at least one second plurality of sensors, and said at least one position sensor comprises at least one inclinometer sensor;
- b) each said at least one inclinometer sensor comprises at least one inclination transducer adapted to provide at least one electrical output proportioned as to the angular variation from gravity vector; and
- 5 c) such at least one electrical output substantially relates to at least one trim angle of such elongated floatable structure.
- 12) The apparatus according to Claim 11 wherein:
- 10 a) each said at least one inclinometer sensor of said at least one first plurality of sensors, said at least one second plurality of sensors, and said at least one position sensor further comprise at least one inclination transducer structured and arranged to provide at least one electrical output proportioned as to the angular variation from gravity vector; and
- 15 b) such at least one electrical output substantially relates to at least one list angle of such elongated floatable structure.
- 13) The apparatus according to Claim 12 wherein:
- a) each said at least one inclinometer sensor of said at least one first plurality of sensors, said at least one second plurality of sensors, and said at least one position sensor further comprise at least one inclination transducer structured and arranged to provide at least one electrical output proportioned as to the angular variation from gravity vector;
- 20 b) such at least one electrical output substantially relates to at least one trim angle and at least one list angle; and
- 25 c) such at least one electrical output is substantially determined by variations of electrical resistance associated with such at least one inclination transducer as such at least one inclination transducer experiences such at least one trim angle and such at least one list angle.
- 14) The apparatus according to Claim 13 wherein:
- 30 a) said at least one controller further comprises at least one sensor-signal collector circuit structured and arranged to attach to said at least one first plurality of sensors and said at least one second plurality of sensors and said at least one position sensor; and

- b) said at least one sensor-signal collector circuit provides at least one sensor-signal converter.
- 15) The apparatus according to Claim 14 wherein said at least one sensor-signal converter converts at least one sensor analog signal to at least one digital signal.
- 5 16) The apparatus according to Claim 15 wherein said at least one sensor-signal collector circuit provides at least one serial data stream to at least one network protocol data stream.
- 17) The apparatus according to Claim 16 wherein such at least one network protocol comprises Ethernet protocol.
- 10 18) The apparatus according to Claim 17 wherein:
- a) said at least one controller further comprises at least one power supply structured and arranged to provide power to said at least one first plurality of sensors and said at least one second plurality of sensors and said at least one position sensor; and
- 15 b) said at least one power supply comprises at least one power circuit adapted to provide power to at least one power-over-Ethernet protocol switch.
- 19) The apparatus according to Claim 16 further comprising such at least one floatable structure.
- 20) The apparatus according to Claim 19 wherein:
- 20 a) said at least one floatable structure comprises at least one dry dock; and
- b) such flowable ballast substance comprises water upon which said at least one dry dock is afloat.
- 21) The apparatus according to Claim 20 wherein said at least one dry dock comprises:
- 25 a) at least one starboard wing-wall extending substantially along such at least one first sub-length;
- b) at least one port wing-wall extending substantially along such at least one second sub-length; and
- c) at least one floor extending substantially between said at least one starboard wing-wall and said at least one port wing-wall;
- 30 d) wherein said first plurality of sensors is attached along said at least one starboard wing-wall;
- e) wherein said second plurality of sensors is attached along said at least one port wing-wall; and

- f) wherein said at least one position sensor is attached midships along said at least one floor.
- 22) A retrofitting method, relating to providing enhanced control of deflections of materials in at least one large, dynamically-supported, elongated structure, wherein such structure comprises a first set of sensors spaced along a first length of such structure, such retrofitting method comprising the steps of:
- 5
- a) providing a second set of sensors to replace such first set of sensors;
- b) wherein essentially each of such second set of sensors comprises a more direct measurement of inclination than essentially each of such first set of sensors; and
- 10
- c) installing such second set of sensors in such structure;
- d) wherein at least one existing controller for controlling such deflections, usable with such first set of sensors, in essentially unmodified form, is useable with such second set of sensors.
- e) The method according to Claim 22 wherein such step of installing such second set of sensors in such structure comprises the step of:
- 15
- f) decoupling such first set of sensors, providing a measure of elevation, from such at least one existing controller ; and
- g) operably coupling such second set of sensors, providing substantially a measure of inclination, with such at least one existing controller.
- 20
- 23) A method, relating to controlling deflections of materials of at least one large, dynamically-supported, elongated floatable structure having a plurality of dynamic support points, comprising the steps of:
- a) installing within such at least one large, dynamically-supported, elongated floatable structure, at least one first set of sensors associated with such materials and respectively spaced at respective sensor locations along at least one first length of such materials substantially parallel to at least one longitudinal axis of such structure; and
- 25
- b) installing within such at least one large, dynamically-supported, elongated floatable structure, at least one controller adapted to take dynamic support action responsive to outputs of such at least one first plurality of sensors;
- 30
- c) installing within such at least one large, dynamically-supported, elongated floatable structure, at least one action system structured and arranged to perform such dynamic support action;

- d) wherein each respective sensor of said at least one first plurality of sensors is essentially adapted to measure respective relative inclination at a respective sensor location along such at least one first length of such materials;
- e) wherein such each such sensor essentially provides information in relation to relative inclinations in respective portions of such structure to such at least one controller;
- f) wherein such dynamic support action by such at least one controller comprises minimizing of such relative inclinations; and
- g) wherein deflections in such materials of such respective portions may be controlled..
- 24) The method according to Claim 23 further comprising the steps of:
- a) identifying within such at least one first length, at least one first sub-length and at least one second sub-length, each one oriented substantially parallel to at least one longitudinal axis of such structure;
- b) arranging such at least one first set of sensors to comprise at least one first plurality of sensors and at least one second plurality of sensors;
- c) spacing such at least one first set of sensors at respective sensor locations along such at least one first sub-length and associating such at least one first set of sensors with such materials of such at least one first sub-length;
- d) spacing such at least one second set of sensors at respective sensor locations along such at least one second sub-length and associating such at least one second set of sensors with such materials of such at least one second sub-length.
- 25) The method according to Claim 24 further comprising the step of:
- a) providing at least one position sensor located midships of such elongated floatable structure; and
- b) operably coupling such at least one position sensor to such at least one controller to essentially provide at least one reference indicating position of such elongated floatable structure with respect to at least one horizon;
- c) wherein such at least one action system, responsive to such at least one controller, essentially assists such structure to seek to remain in essentially a horizontal plane.
- 26) The method according to Claim 25 further comprising the steps of:

- a) merging information from such at least one first plurality of sensors, such at least one second plurality of sensors, and such at least one position sensor within such at least one controller;
- b) determining at least one action by such at least one action system, using such merged data, to essentially assists such structure to seek to remain in such essentially a horizontal plane; and
- c) initiating by such at least one controller, such at least one action of such at least one action system.
- 27) The method according to Claim 26 further comprising the steps of:
- a) providing within such at least one action system, at least one ballast-pumping-system interface adapted to assist action-system controlled pumping of at least one flowable ballast substance by at least one ballast pumping system of such elongated floatable structure;
- b) providing within such at least one action system, at least one plurality of ballast-tank sensors structured and arranged to respectively measure the flowable ballast substance contained within a plurality of ballast tanks of such elongated floatable structure, wherein such at least one pumping-system interface is structured and arranged to assist move such flowable ballast substance in and out of selected ballast tanks among such at least one plurality of ballast tanks in accordance with control of such at least one controller; and
- c) providing within such at least one action system, at least one ballast-valving interface structured and arranged to interface with at least one ballast-valving system of such elongated floatable structure;
- d) wherein said at least one ballast-valving interface is structured and arranged to respond to such at least one controller; and
- e) wherein such at least one ballast-valving interface is further structured and arranged to selectively enable such at least one flowable ballast substance to selectively flow into or out of individual ballast tanks of such at least one plurality of ballast tanks.
- 28) The method according to Claim 27 further comprising the step of connecting essentially each of said first plurality of sensors, said second plurality of sensors, and said position sensor to such at least one control system by at least one network having at least one network protocol.

- 29) An apparatus, relating to monitoring deflections of materials of at least one large, floating, elongated dry dock, comprising:
- 5 a) at least one first plurality of sensors associated with such materials and respectively spaced at respective sensor locations along at least one first length of such materials substantially parallel to at least one longitudinal axis of such structure; and
- 10 b) at least one monitor adapted to make indications responsive to outputs of such at least one first plurality of sensors;
- c) wherein each respective sensor of such at least one first plurality of sensors is essentially adapted to measure respective relative inclination at a respective sensor location along such at least one first length of such materials;
- d) wherein such each such sensor essentially provides information in relation to relative inclinations in respective portions of such structure to such at least one monitor; and
- 15 e) wherein deflections in such materials of such respective portions may be monitored.

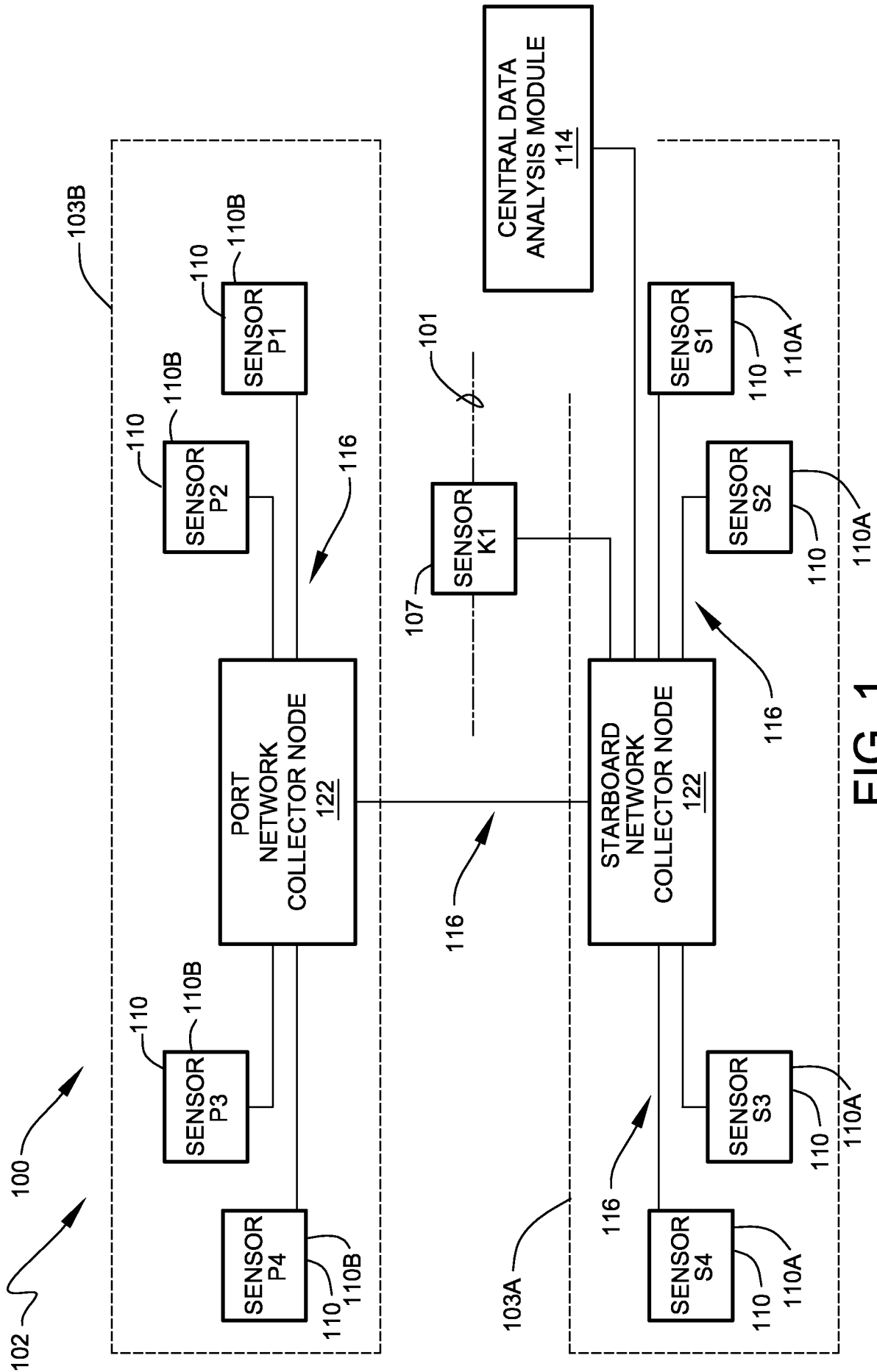

FIG. 1

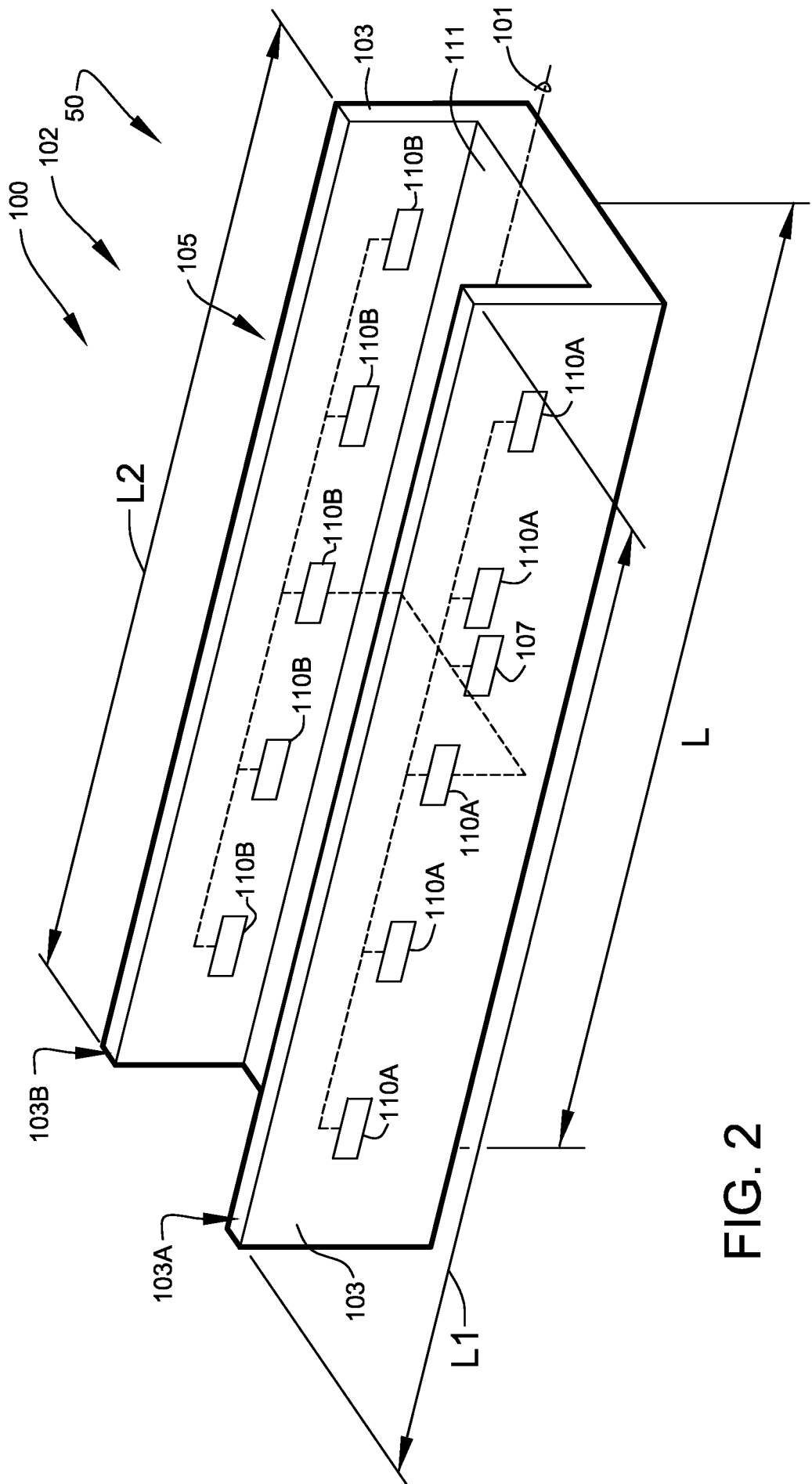

FIG. 2

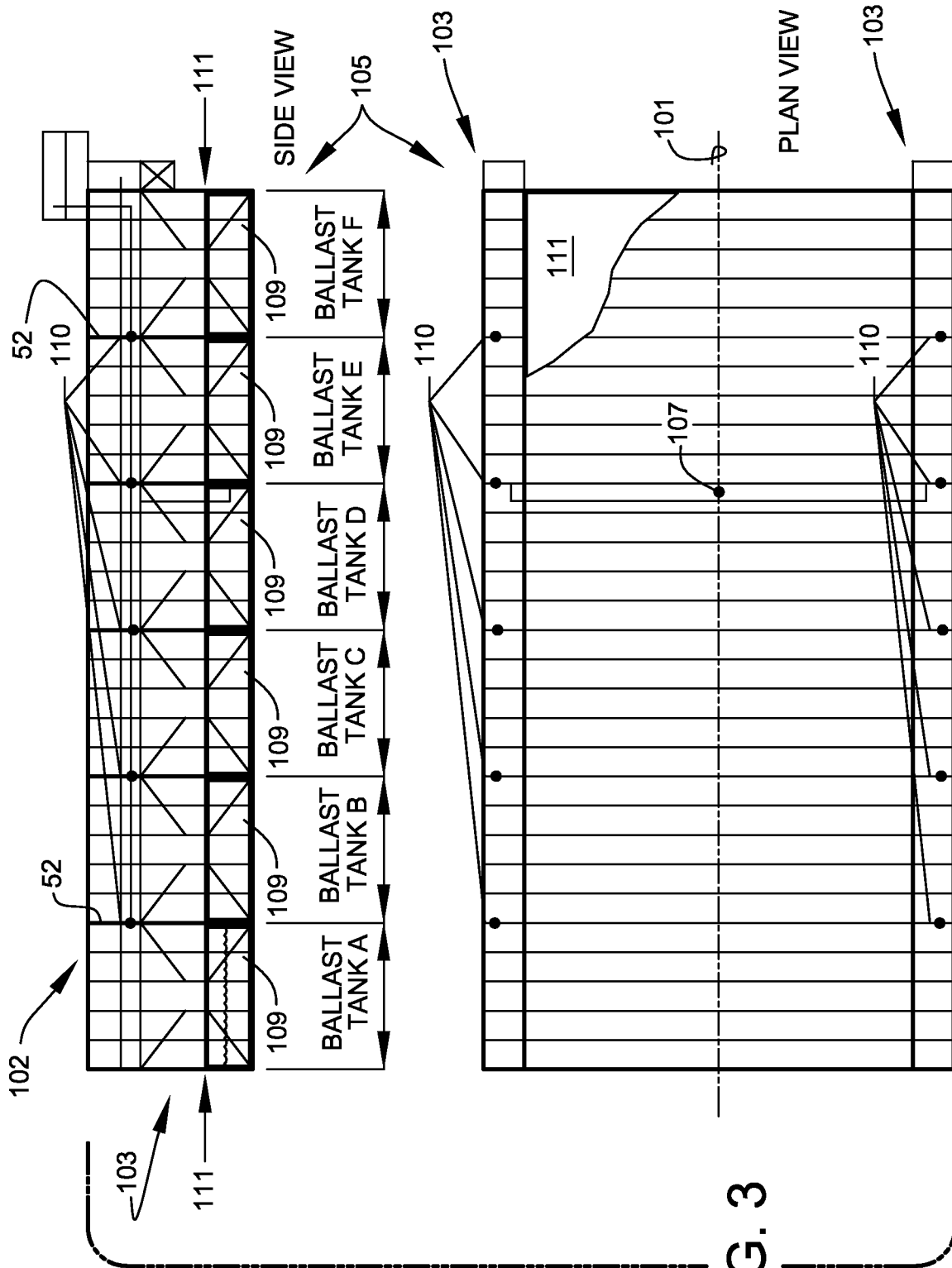

FIG. 3

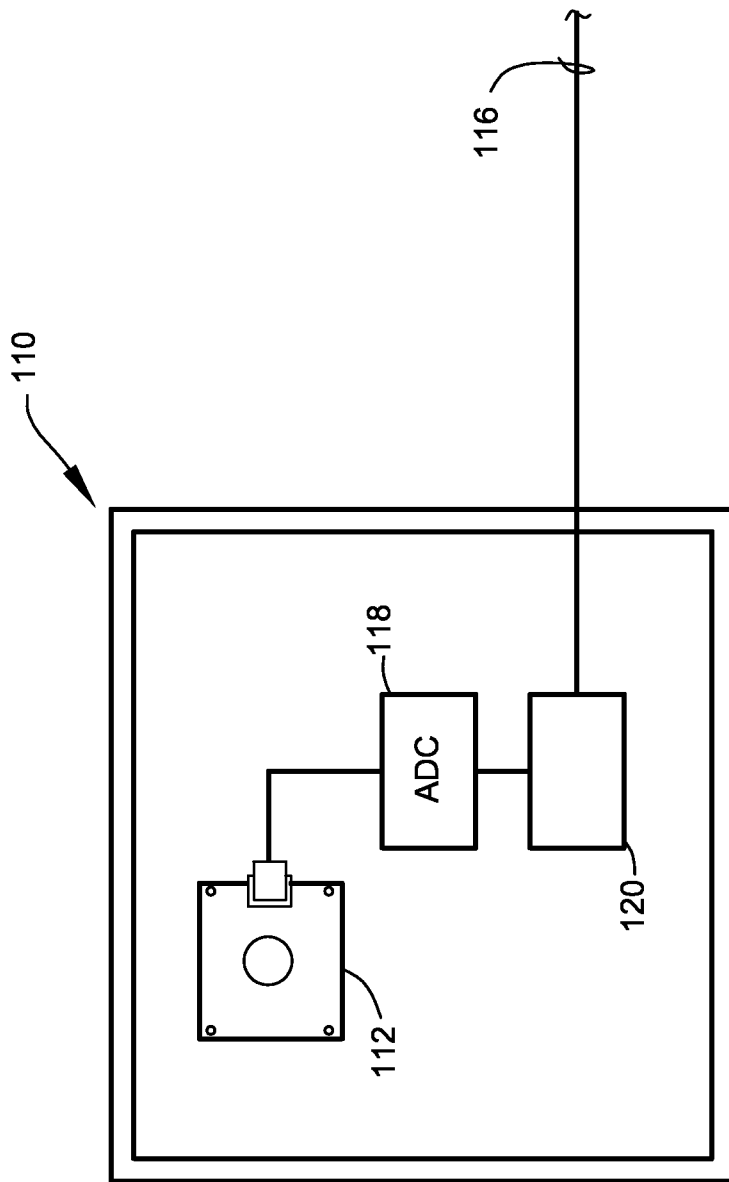

FIG. 4

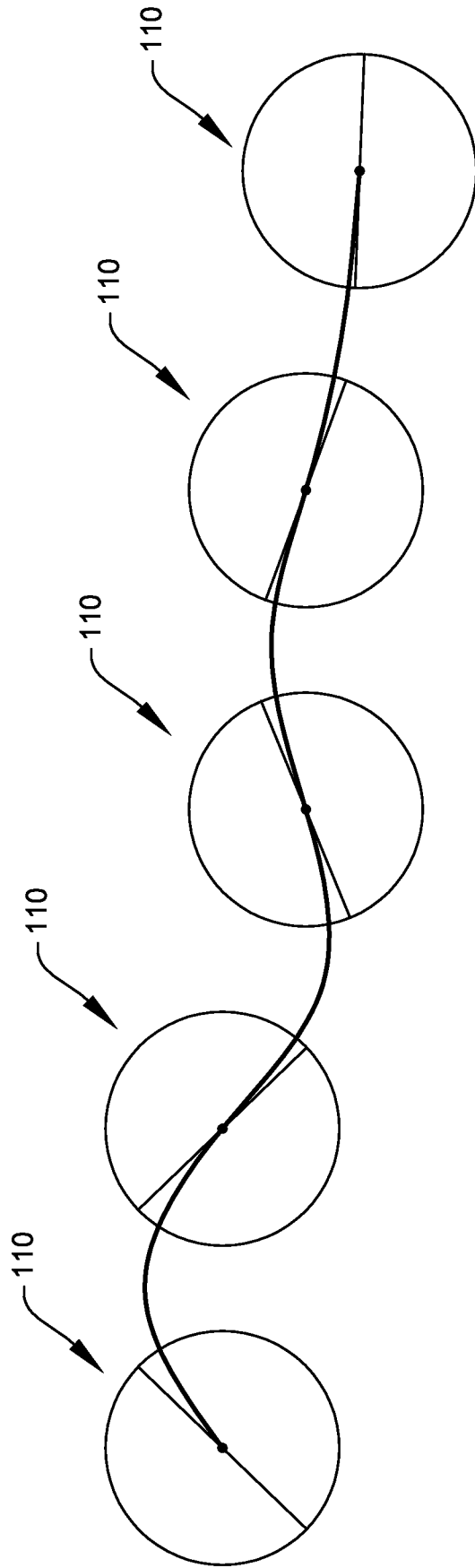

FIG. 5

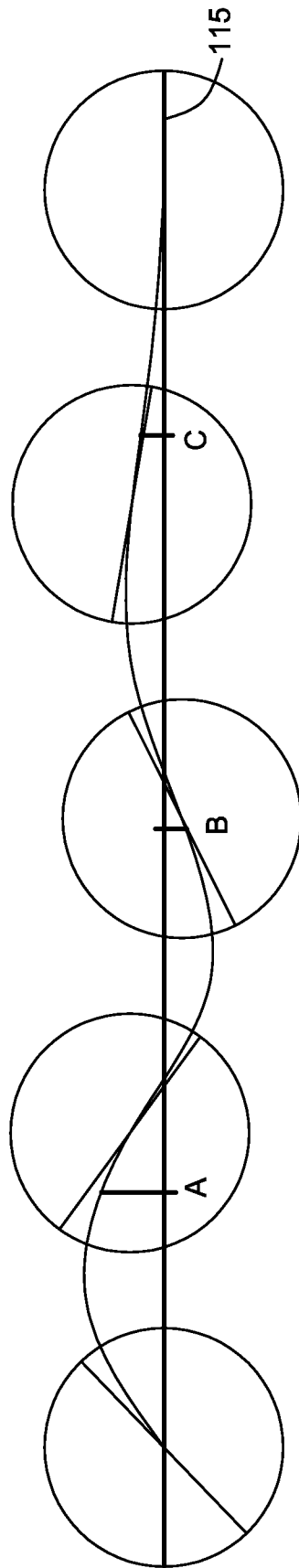

FIG. 6

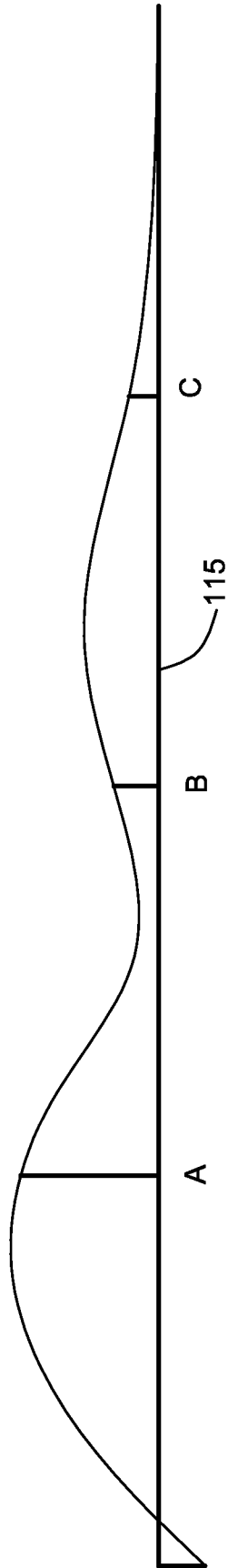

FIG. 7

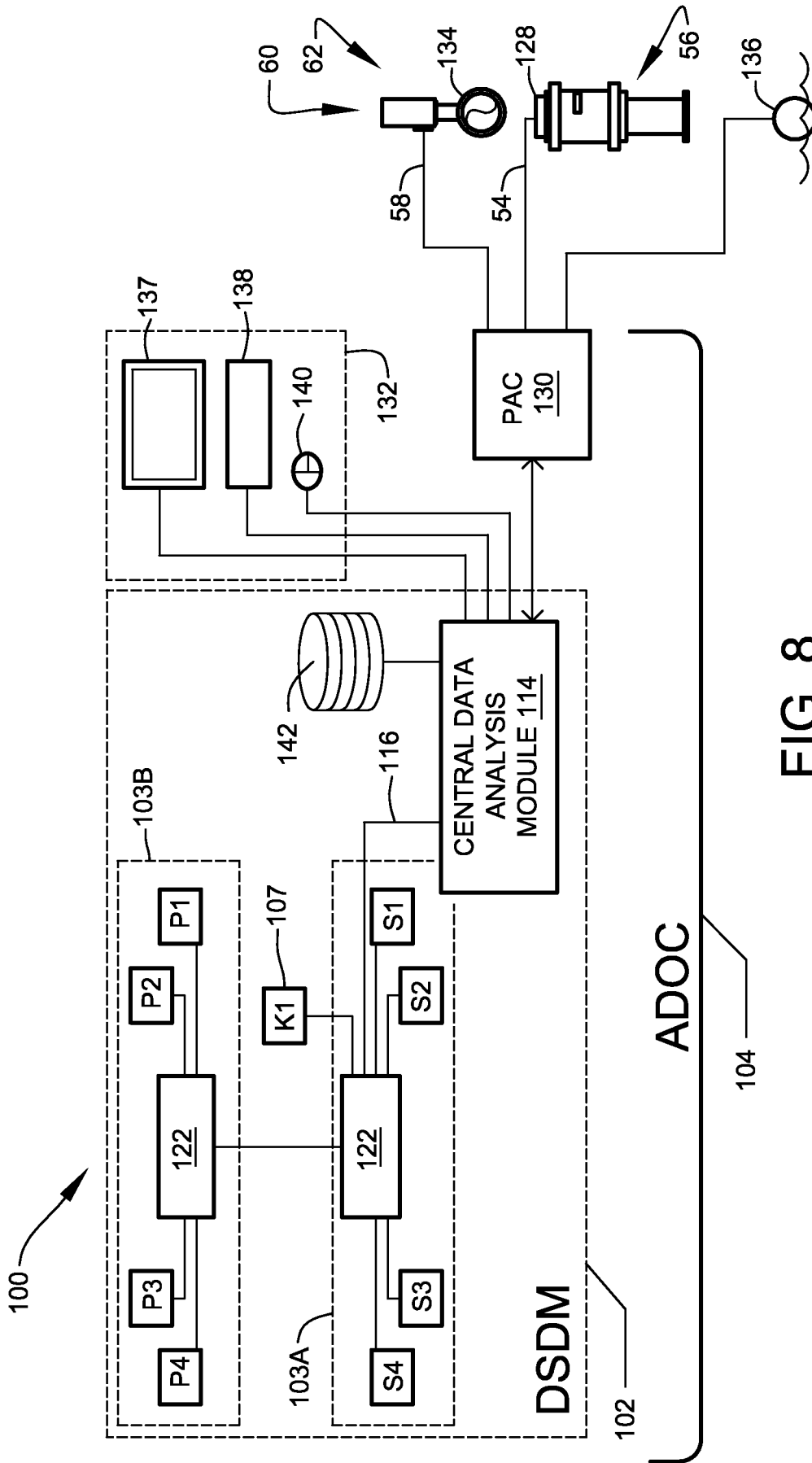

FIG. 8

9/17

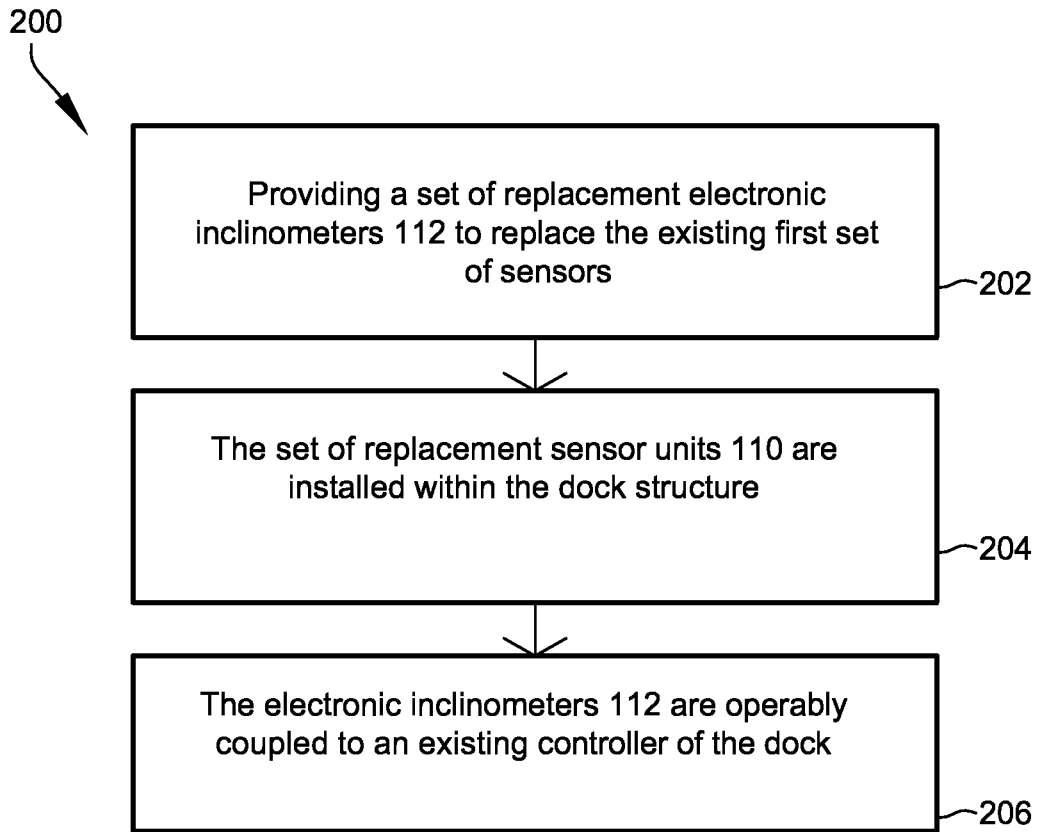

FIG. 9

10/17

300
↙

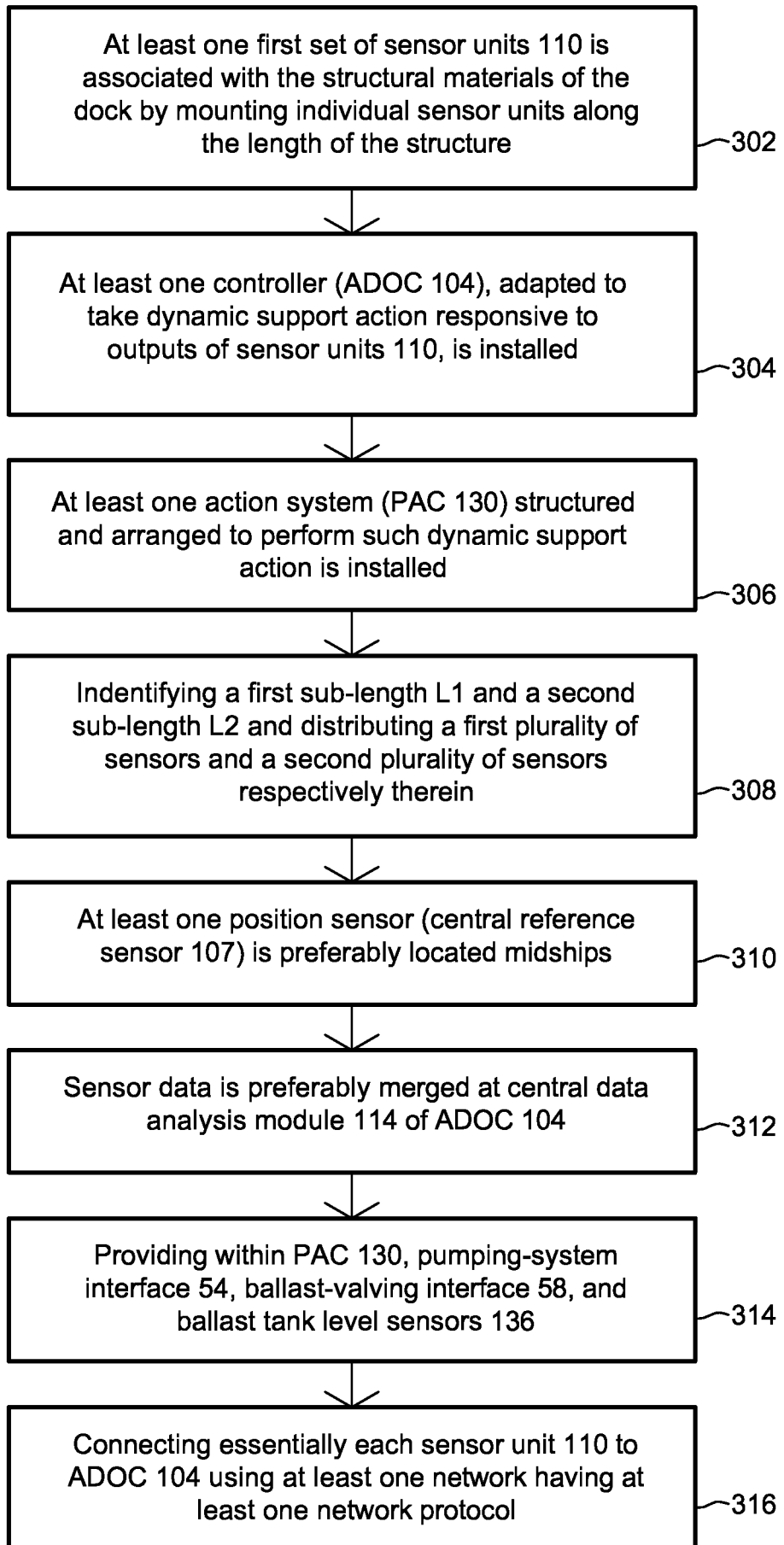

FIG. 10

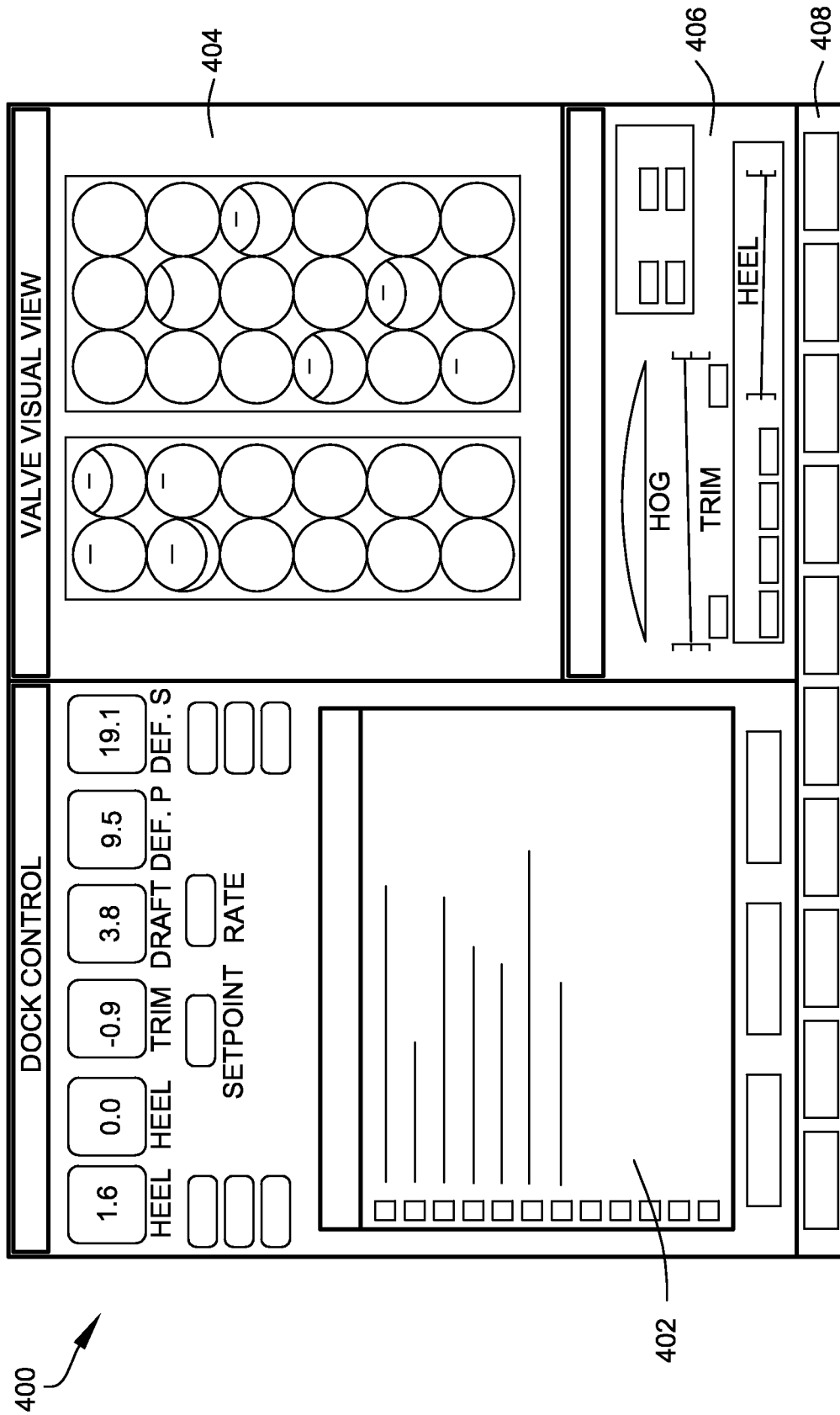

FIG. 11

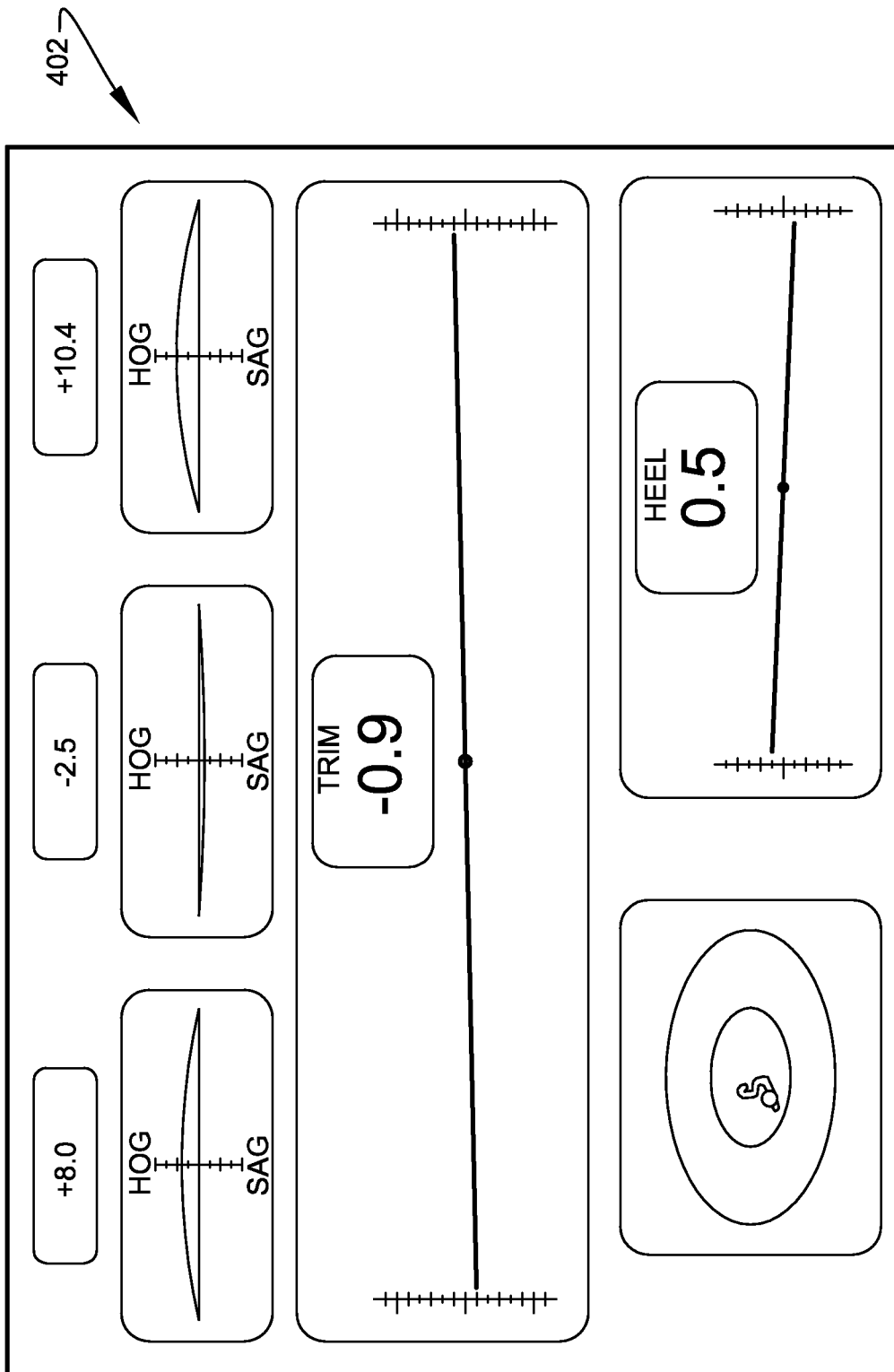

FIG. 12

404 ↘

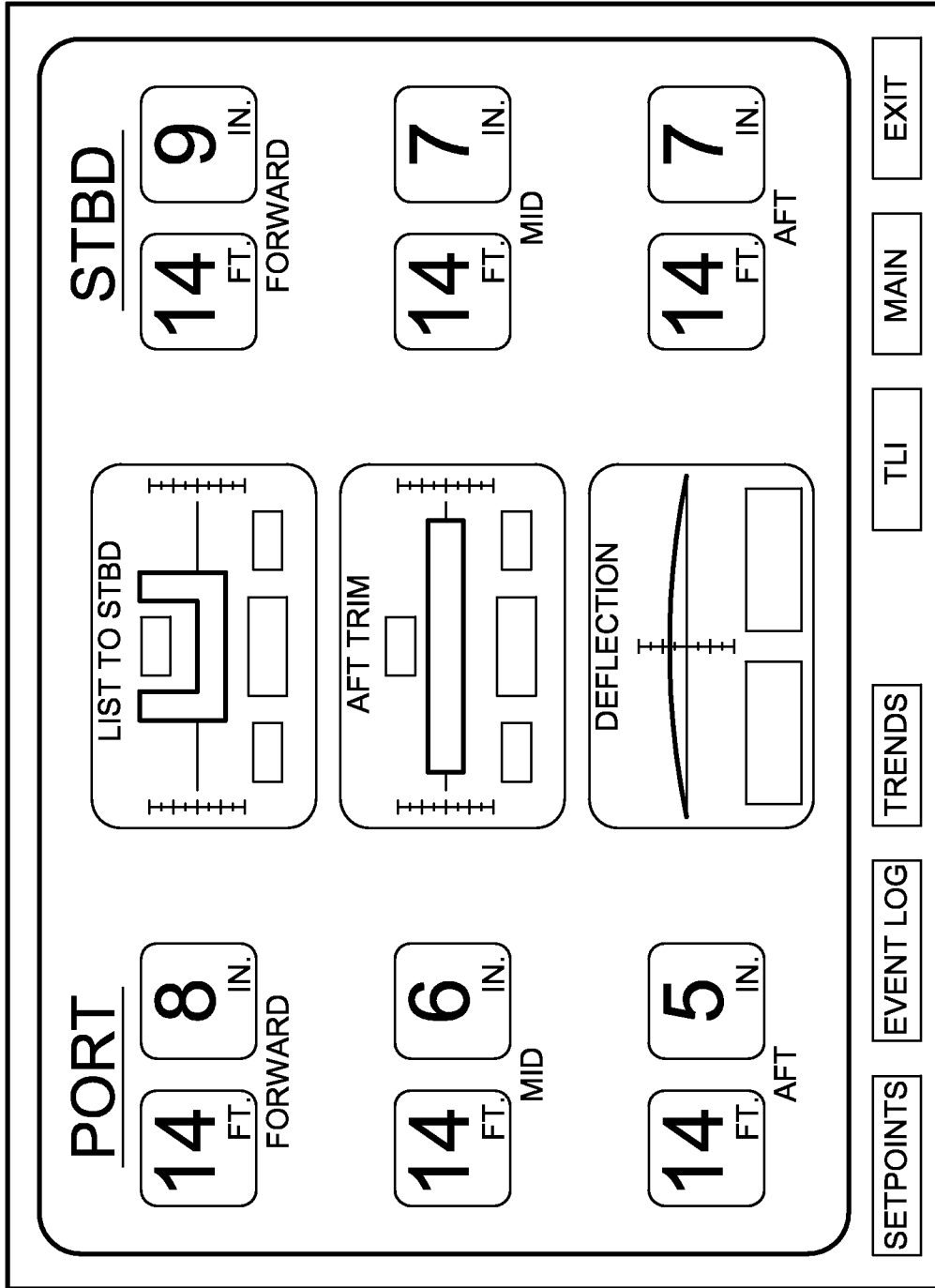

FIG. 13

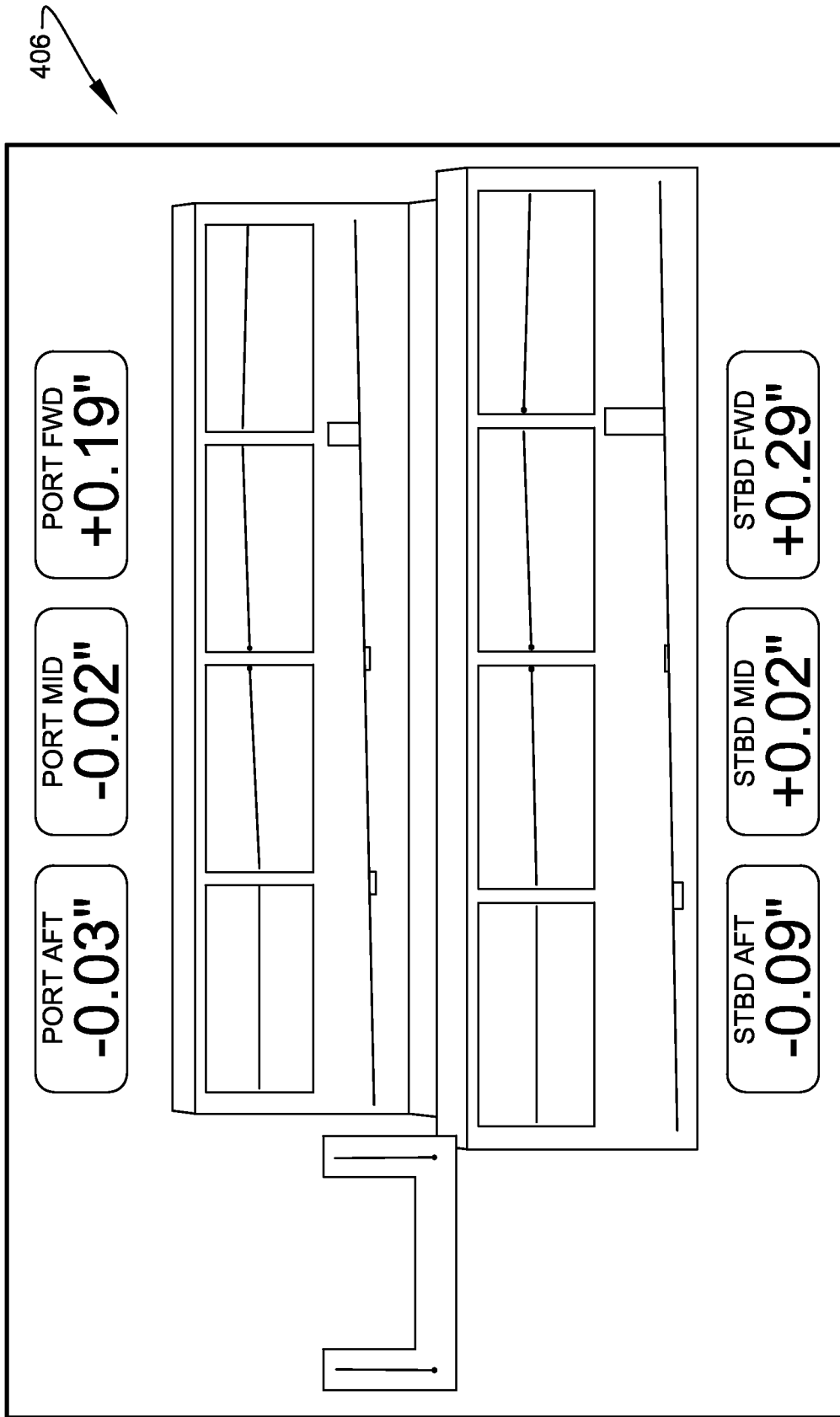

FIG. 14

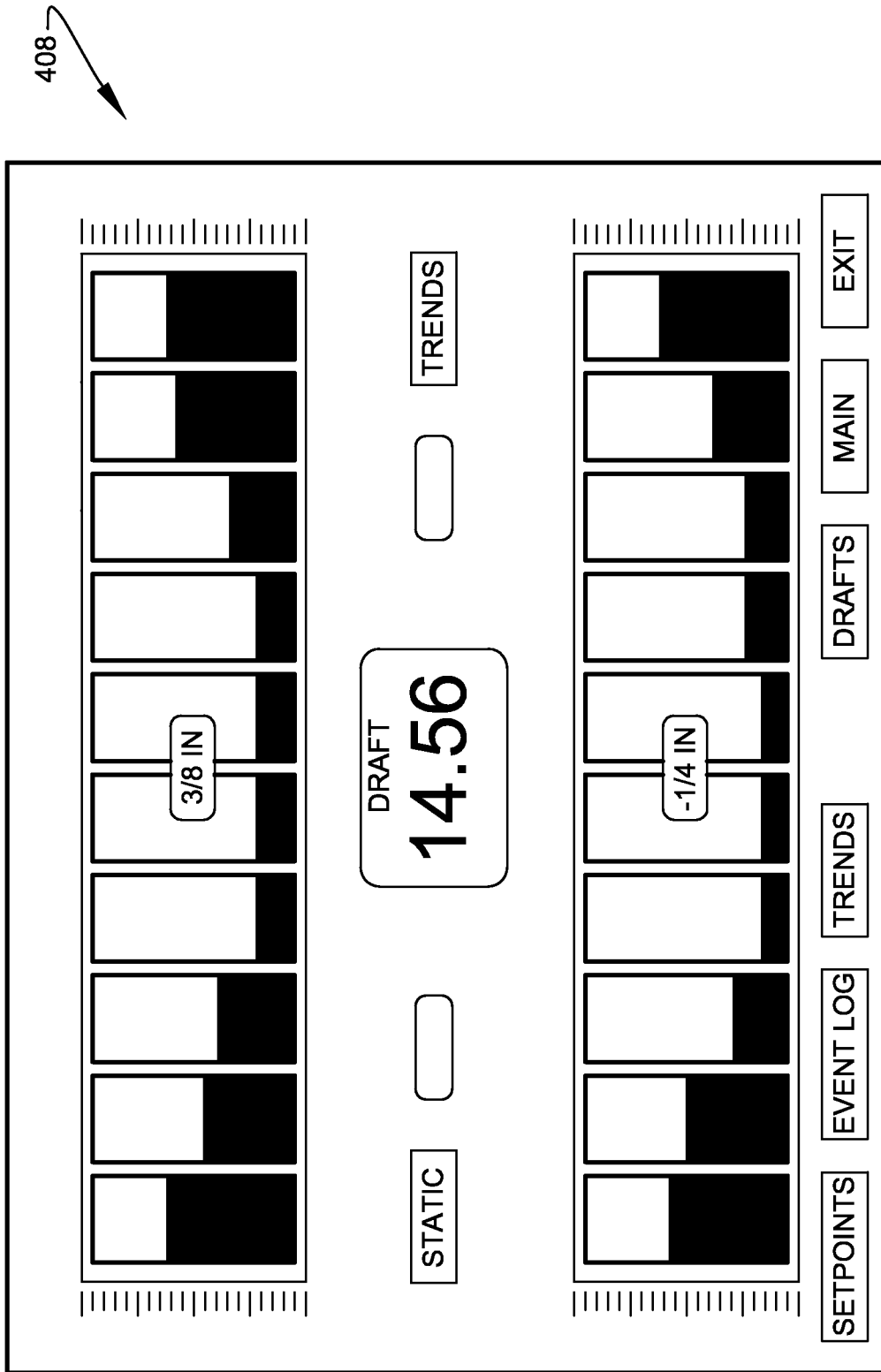

FIG. 15

410 →

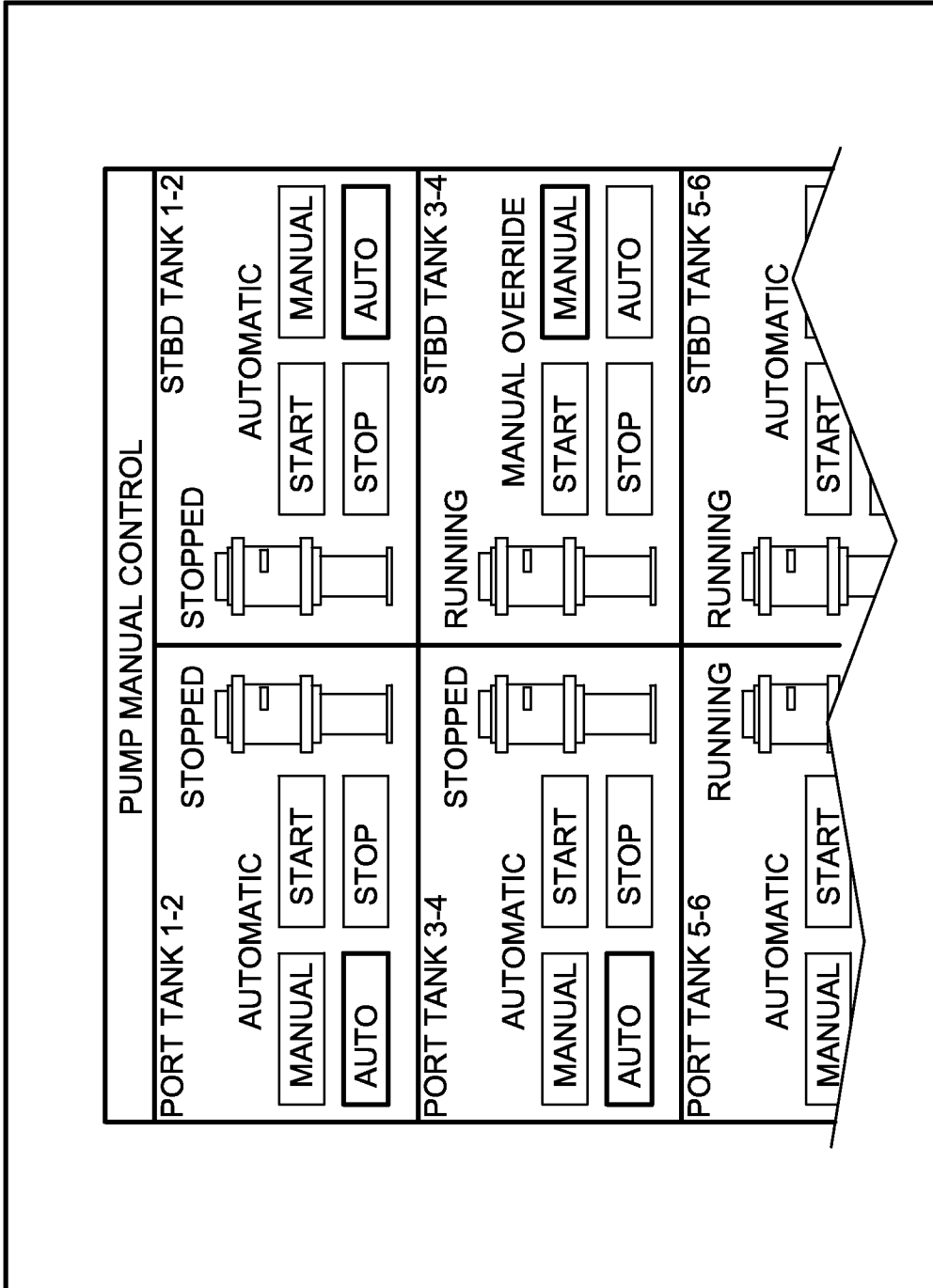

FIG. 16

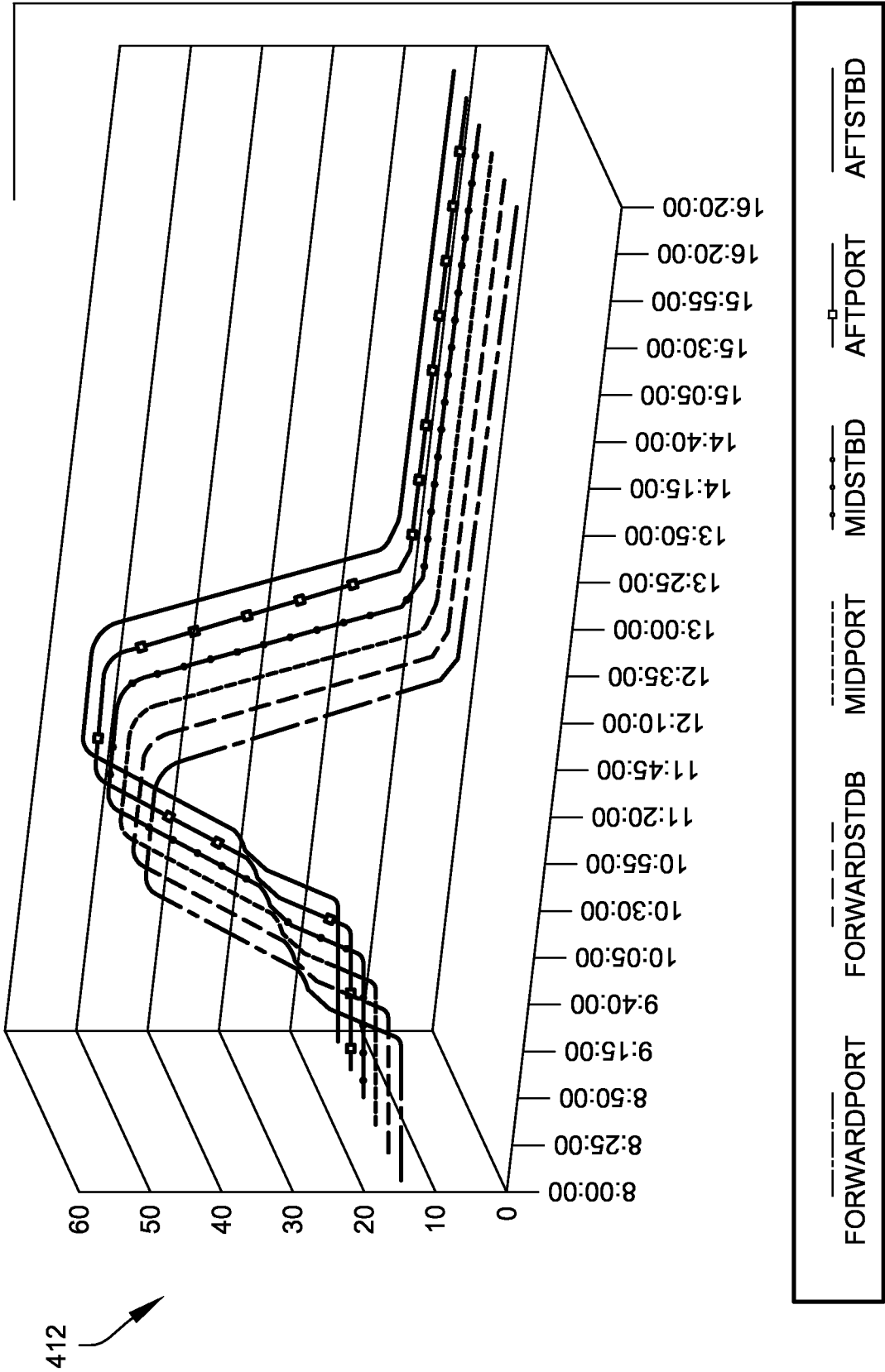

FIG. 17