

(19) World Intellectual Property Organization
International Bureau



(43) International Publication Date
11 February 2010 (11.02.2010)

PCT

(10) International Publication Number
WO 2010/017211 A2

(51) International Patent Classification:
F25B 40/04 (2006.01) F25B 40/00 (2006.01)
F25B 41/00 (2006.01)

(21) International Application Number:
PCT/US2009/052727

(22) International Filing Date:
4 August 2009 (04.08.2009)

(25) Filing Language: English

(26) Publication Language: English

(30) Priority Data:
61/085,911 4 August 2008 (04.08.2008) US
61/114,880 14 November 2008 (14.11.2008) US
12/534,798 3 August 2009 (03.08.2009) US

(71) Applicant (for all designated States except US): **LEABO, Dianne** [US/US]; 4029 W. Morrow Dr., Glendale, AZ 85308 (US).

(71) Applicant and
(72) Inventor: **LEABO, Lawrence, D.** [US/US]; 4029 W. Morrow Dr., Glendale, AZ 85308 (US).

(74) Agent: **VOLK, Michael, D., Jr.**; Stoneman Volk Patent Group, 3770 N. 7th St., Suite 100, Phoenix, AZ 85014-5022 (US).

(81) Designated States (unless otherwise indicated, for every kind of national protection available): AE, AG, AL, AM, AO, AT, AU, AZ, BA, BB, BG, BH, BR, BW, BY, BZ, CA, CH, CL, CN, CO, CR, CU, CZ, DE, DK, DM, DO, DZ, EC, EE, EG, ES, FI, GB, GD, GE, GH, GM, GT, HN, HR, HU, ID, IL, IN, IS, JP, KE, KG, KM, KN, KP, KR, KZ, LA, LC, LK, LR, LS, LT, LU, LY, MA, MD, ME, MG, MK, MN, MW, MX, MY, MZ, NA, NG, NI, NO, NZ, OM, PE, PG, PH, PL, PT, RO, RS, RU, SC, SD, SE, SG, SK, SL, SM, ST, SV, SY, TJ, TM, TN, TR, TT, TZ, UA, UG, US, UZ, VC, VN, ZA, ZM, ZW.

[Continued on next page]

(54) Title: REFRIGERATION HOT GAS DESUPERHEATER SYSTEMS

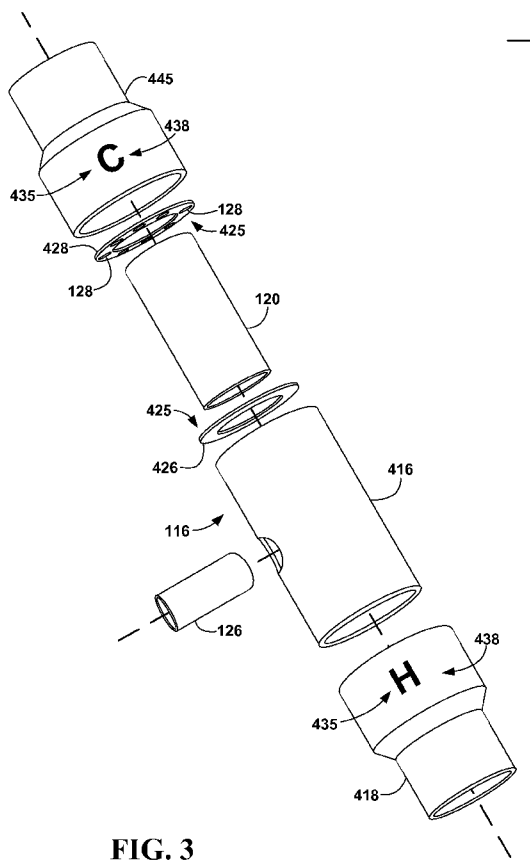

(57) Abstract: A system for desuperheating hot gaseous refrigerant using both a heat exchanger and a dispersed Venturi-driven injection of liquid refrigerant is disclosed. Further, a system, relating to cooling at least one compressed superheated refrigerant fluid prior to condensing, relating to extending the life of at least one condenser is disclosed.



WO 2010/017211 A2

(84) Designated States (*unless otherwise indicated, for every kind of regional protection available*): ARIPO (BW, GH, GM, KE, LS, MW, MZ, NA, SD, SL, SZ, TZ, UG, ZM, ZW), Eurasian (AM, AZ, BY, KG, KZ, MD, RU, TJ, TM), European (AT, BE, BG, CH, CY, CZ, DE, DK, EE, ES, FI, FR, GB, GR, HR, HU, IE, IS, IT, LT, LU, LV, MC, MK, MT, NL, NO, PL, PT, RO, SE, SI, SK, SM, TR), OAPI (BF, BJ, CF, CG, CI, CM, GA, GN, GQ, GW, ML, MR, NE, SN, TD, TG).

Declarations under Rule 4.17:

— *of inventorship (Rule 4.17(iv))*

Published:

— *without international search report and to be republished upon receipt of that report (Rule 48.2(g))*

REFRIGERATION HOT GAS DESUPERHEATER SYSTEMS

BACKGROUND

This invention relates to providing a system for improved refrigeration hot-gas desuperheating. More particularly, this invention relates to providing a system for desuperheating hot gaseous refrigerant using an injection of liquid refrigerant.

Mechanical refrigeration is typically accomplished by circulating, evaporating, and condensing a supply of chemical refrigerant in a continuous thermodynamic cycle. In a typical refrigeration cycle, low pressure vapor refrigerant is compressed by a mechanical compressor and discharged as a pressure superheated vapor. The high pressure refrigerant flows to the condenser by way of a "discharge line". The condenser is used to change the high pressure refrigerant from a high temperature vapor to a lower temperature liquid that exits the condenser through a "liquid runoff line". The liquid refrigerant then flows to a thermal expansion valve where the high pressure liquid is changed to a low-pressure, low-temperature vapor. The low-pressure, low-temperature vapor enters the evaporator where a useful heat exchange typically occurs. The low pressure vapor is then returned to the mechanical compressor and the cycle then repeats.

The chemical refrigerant absorbs heat at several points in the refrigeration cycle. Heat is initially absorbed in the evaporator. Further, heat is absorbed by the refrigerant during the compression, such that superheated gaseous refrigerant is discharged from the compressor to the discharge line.

Superheating is a major drawback in refrigeration systems utilizing commercial water-cooled condensers in that passage of the superheated gas through such a condenser can result in the development of detrimental scale deposits (scaling) on the heat-exchanging surfaces. The water used in these condensers typically contains traces of calcium bicarbonate and other dissolved salts that can form water-insoluble deposits when exposed to excessive heat. It would be useful to provide a means for desuperheating of the gaseous refrigerant prior to condensing would reduce such scaling through a proportional reduction of water temperature. Such a method might beneficially extend the time the condenser may operate without maintenance (descaling of the coils, coil replacement, etc.), and may further benefit operation by reducing the amount of scale-inhibiting chemicals that must be added to such systems.

It is clear from the above discussion that improved methods of desuperheating gaseous refrigerant prior to movement through such condensers would be of benefit to those whose commerce is dependent on such mechanical systems.

OBJECTS AND FEATURES OF THE INVENTION

A primary object and feature of the present invention is to provide a system addressing the above-described problems.

It is a further object and feature of the present invention to provide such a system comprising at least one fitting adapted to desuperheat refrigerant gas by mixing superheated gas refrigerant with a cooler liquid refrigerant.

It is a further object and feature of the present invention to provide a system comprising at least one fitting adapted to desuperheat refrigerant gas through a multistage process, with at least one heat exchange and at least one injection.

Another object and feature of the present invention is to provide a system adaptable to a range of “discharge line” sizes.

A further object and feature of the present invention is to provide a system with passive drawing of liquid refrigerant to inject into superheated gas refrigerant.

Yet another object and feature of the present invention is to provide a system designed to be able to operate level with the condenser of a refrigeration cycle.

It is a further object and feature of the present invention to provide a system using the “Venturi Effect” to passively suction liquid refrigerant to inject into superheated gas refrigerant.

A further object and feature of the present invention is to provide such a system, which, when used, may extend the life of at least one water cooled condenser in a refrigeration cycle through assisting prevention of “flash vaporization” of water in such water cooled condenser.

Another object and feature of the present invention is to provide such a system, which can also be used in the defrost cycle of a refrigeration cycle to extend the life of at least one evaporator in such refrigeration cycle by assisting prevention of excessive thermal shock.

A further primary object and feature of the present invention is to provide such a system that is efficient, inexpensive, and handy. Other objects and features of this invention will become apparent with reference to the following descriptions.

SUMMARY OF THE INVENTION

In accordance with a preferred embodiment hereof, this invention provides a system, relating to cooling at least one superheated refrigerant fluid during at least one heat cycle, such system comprising: at least one heat exchanger structured and arranged to exchange heat between at least one cooling fluid and the at least one superheated refrigerant fluid to decrease temperature differential between such at least one cooling fluid and such at least one superheated refrigerant fluid; at least one injector, structured and arranged to inject such at least one cooling fluid into the at least one superheated refrigerant fluid after exchange of heat in such at least one

heat exchanger; and at least one fluid mixer structured and arranged to mix such injected cooling fluid and the at least one superheated refrigerant fluid to produce at least one desuperheated refrigerant fluid having at least one state substantially near at least one saturated state; wherein such at least one heat exchanger comprises at least one suction creator structured and arranged to create suction to draw such at least one cooling fluid into such at least one heat exchanger by decreasing localized pressure near such at least one injector; and wherein such at least one suction creator assists injection by such at least one injector.

Moreover, it provides such a system wherein such at least one suction creator comprises at least one separator structured and arranged to physically separate such at least one cooling fluid from the at least one superheated refrigerant fluid, while allowing exchange of heat in such at least one heat exchanger by transmitting heat through such at least one separator.

Additionally, it provides such a system wherein such at least one suction creator comprises at least one tube. Also, it provides such a system wherein such at least one tube is structured and arranged to: contain flow of the at least one superheated refrigerant fluid inside such at least one tube; and separate flow of such at least one cooling fluid substantially around at least one perimeter of such at least one tube.

In addition, it provides such a system wherein such at least one injector is structured and arranged to inject such at least one cooling fluid into the at least one superheated refrigerant fluid substantially evenly around at least one perimeter of flow of the at least one superheated refrigerant fluid. And, it provides such a system wherein such at least one injector comprises at least one injector port. Further, it provides such a system wherein such at least one injector comprises a plurality of such at least one injector ports evenly spaced about the perimeter of the flow of the at least one superheated refrigerant fluid. Even further, it provides such a system wherein: when connected to at least one discharge line, the diameter of such at least one injector port multiplied by the quantity of such plurality of such at least one injection ports comprises about the diameter of at least one discharge line. Moreover, it provides such a system wherein the diameter of such at least one injector port comprises between about 1/8 inch and about 1/2 inch. Additionally, it provides such a system wherein the diameter of such at least one injector port comprises about 3/8 inch.

Also, it provides such a system wherein the diameter of such at least one injector port comprises about 1/4 inch. In addition, it provides such a system further comprising at least one outer container structured and arranged to contain such at least one cooling fluid substantially near such at least one separator. And, it provides such a system further comprising at least one discharge line structured and arranged to fit at least one discharge line. Further, it provides such

a system wherein such at least one suction creator is substantially cylindrical. Even further, it provides such a system wherein such at least one outer container is substantially cylindrical. Moreover, it provides such a system wherein the difference between the diameter of such at least one discharge line and the diameter of such at least one suction creator comprises between about 1/2 inch and about 1/4 inch.

Additionally, it provides such a system wherein the difference between the diameter of such at least one outer container and the diameter of such at least one suction creator comprises between about 2 inches and about 1 inch. Also, it provides such a system wherein the diameter of such at least one outer container comprises about 2-5/8 inches. In addition, it provides such a system wherein the diameter of such at least one discharge line comprises about 7/8 inches. And, it provides such a system wherein the diameter of such at least one suction creator comprises about 5/8 inches. Further, it provides such a system wherein the diameter of such at least one discharge line comprises about 1-1/8 inches. Even further, it provides such a system wherein the diameter of such at least one suction creator comprises about 7/8 inches. Moreover, it provides such a system wherein the diameter of such at least one discharge line comprises about 1-3/8 inches. Additionally, it provides such a system wherein the diameter of such at least one suction creator comprises about 1-1/8 inches. Also, it provides such a system wherein the diameter of such at least one outer container comprises about 3-1/8 inches. In addition, it provides such a system wherein the diameter of such at least one discharge line comprises about 1-5/8 inches. And, it provides such a system wherein the diameter of such at least one suction creator comprises about 1-3/8 inches.

Further, it provides such a system wherein the diameter of such at least one discharge line comprises about 2-1/8 inches. Even further, it provides such a system wherein the diameter of such at least one suction creator comprises about 1-5/8 inches. Moreover, it provides such a system wherein the diameter of such at least one discharge line comprises about 2-5/8 inches. Additionally, it provides such a system wherein the diameter of such at least one suction creator comprises about 2-1/8 inches. Also, it provides such a system wherein the diameter of such at least one outer container comprises about 3-5/8 inches. In addition, it provides such a system wherein the diameter of such at least one discharge line comprises about 3-1/8 inches. And, it provides such a system wherein the diameter of such at least one suction creator comprises about 2-5/8 inches. Further, it provides such a system wherein such at least one injector comprises metal.

Even further, it provides such a system wherein such at least one injector comprises brass. Even further, it provides such a system wherein such at least one injector comprises

copper. Even further, it provides such a system wherein such at least one heat exchanger comprises metal. Even further, it provides such a system wherein such at least one heat exchanger comprises copper.

In accordance with another preferred embodiment hereof, this invention provides a method, relating to cooling at least one superheated refrigerant fluid during at least one heat cycle, such method comprising the steps of: exchanging heat, in at least one heat exchanger, between at least one cooling fluid and the at least one superheated refrigerant fluid to decrease temperature differential between such at least one cooling fluid and the at least one superheated refrigerant fluid; injecting, using at least one injector, such at least one cooling fluid into the at least one superheated refrigerant fluid after the step of exchanging heat; mixing such injected cooling fluid and the at least one superheated refrigerant fluid to produce at least one desuperheated refrigerant fluid having at least one state substantially near at least one saturated state; and creating suction to draw such at least one cooling fluid into such at least one heat exchanger by decreasing localized pressure near such at least one injector; wherein such suction assists injection by such at least one injector.

In accordance with another preferred embodiment hereof, this invention provides a system, relating to cooling at least one superheated refrigerant during at least one heat cycle, such system comprising: heat exchanger means for exchanging heat between at least one cooling fluid and the at least one superheated refrigerant fluid to decrease temperature differential between such at least one cooling fluid and the at least one superheated refrigerant fluid; injector means for injecting such at least one cooling fluid into the at least one superheated refrigerant fluid after exchange of heat in such at least one heat exchanger; fluid mixer means for mixing such injected cooling fluid and the at least one superheated refrigerant fluid to produce at least one desuperheated refrigerant fluid having at least one state substantially near at least one saturated state; wherein such heat exchanger means comprises suction creator means for creating suction to draw such at least one cooling fluid into such heat exchanger means by decreasing localized pressure near such injector means; and wherein such suction creator means assists injection by such injector means.

In accordance with another preferred embodiment hereof, this invention provides a method, relating to cooling at least one superheated refrigerant batch during at least one heat cycle, such method comprising the steps of: creating suction to draw at least one cooler refrigerant batch into heat exchange relationship with such at least one superheated refrigerant batch; exchanging heat between such at least one superheated refrigerant batch and at least one cooler refrigerant batch to decrease temperature differential between such at least one

superheated refrigerant batch and such at least one cooler refrigerant batch and form at least one cooler superheated refrigerant batch; injecting such at least one cooler refrigerant batch into the at least one cooler superheated refrigerant batch after the step of exchanging heat; and mixing such at least one cooler refrigerant batch and such at least one cooler superheated refrigerant batch to produce at least one desuperheated refrigerant batch having at least one portion substantially near at least one saturated state.

And it provides for each and every novel feature, element, combination, step and/or method disclosed or suggested by this patent application.

BRIEF DESCRIPTION OF THE DRAWINGS

FIG. 1 shows a schematic diagram, illustrating the primary components of a refrigeration cycle utilizing at least one hot-gas desuperheater circuit, according to a preferred embodiment of the present invention.

FIG. 2 shows a longitudinal cross-sectional view through the hot-gas desuperheater fitting, according to the preferred embodiment of FIG. 1.

FIG. 3 shows an exploded view of the hot-gas desuperheater fitting of FIG. 2.

FIG. 4 shows a schematic diagram, illustrating the primary components of a refrigeration cycle utilizing at least one defrosting injection circuit, according to another preferred embodiment of the present invention.

FIG. 5 shows a longitudinal cross-sectional view, through another hot-gas desuperheater fitting, according to an alternately preferred embodiment of the present invention.

DETAILED DESCRIPTION OF THE BEST MODES AND PREFERRED EMBODIMENTS OF THE INVENTION

FIG. 1 shows a schematic diagram, illustrating the primary components of a refrigeration cycle **101** at least one utilizing hot-gas desuperheater circuit **102**, according to a preferred embodiment of the present invention.

In the refrigeration cycle depicted in FIG. 1, at least one mechanical compressor **106** preferably compresses low-pressure vapor refrigerant **130**, preferably to form a high-temperature vapor **140**, which preferably discharges into at least one discharge line **110**. High-temperature vapor **140** enters discharge line **110** superheated as high-temperature superheated vapor **132**, as shown. Discharge line **110** preferably transports high-temperature vapor **140** to at least one condenser **108**, as shown.

Condenser **108** preferably comprises at least one water-cooled condenser **408**. Condenser **108** preferably condenses high-temperature vapor **140** to form a lower-temperature liquid **136** that preferably exits condenser **108** through at least one liquid runoff line **112**, as shown. Liquid

runoff line **112** preferably transports lower-temperature liquid **136** to expansion valve **124**, as shown.

Expansion valve **124** preferably rapidly lowers the pressure in liquid runoff line **112**, preferably causing a portion of lower-temperature liquid **136** to vaporize, preferably forming a mixed vapor/liquid refrigerant **138**, as shown. At least one evaporator feed line **142** preferably carries mixed vapor/liquid refrigerant **138** to at least one evaporator **146**, as shown.

Evaporator **146** preferably vaporizes the remaining liquid in mixed vapor/liquid refrigerant **138**, preferably through the transfer of heat, preferably from the environment around evaporator **146**, to mixed vapor/liquid refrigerant **138**, preferably forming low-pressure vapor refrigerant **130**, as shown. At least one suction line **144** preferably transports low-pressure vapor refrigerant **130** to mechanical compressor **106** where refrigeration cycle **101** may repeat, as shown.

Refrigerant, cycled through refrigeration cycle (low-pressure vapor refrigerant **130**, high-temperature vapor **140**, lower-temperature liquid **136**, and mixed vapor/liquid refrigerant **138**.), preferably comprises Freon. Upon reading this specification, those skilled in the art will now appreciate that, under appropriate circumstances, considering such issues as cost, future industry regulations, future technology, etc., other refrigerants, such as, for example, water, glycol, coolant mixtures, etc., may suffice.

Hot-gas desuperheater circuit **102** is preferably added to refrigeration cycle **101** to desuperheat high-temperature vapor **140**, preferably forming high-temperature desuperheated vapor **134**, preferably prior to entering condenser **108**, as shown. More specifically, at least one liquid refrigerant transfer line **114** preferably connects between liquid runoff line **112** and discharge line **110**, preferably to divert a portion of lower-temperature liquid **136**, exiting water-cooled condenser **108**, to discharge line **110**, as shown. Hot-gas desuperheater circuit **102** preferably comprises to at least one check valve **404**, as shown, in liquid refrigerant transfer line **114**, preferably to prevent backflow of high-temperature vapor **140** into liquid refrigerant transfer line **114**.

Hot-gas desuperheater circuit **102** preferably comprises hot-gas desuperheater fitting **104** in fluid communication with liquid runoff line **112** by means of liquid refrigerant transfer line **114**, as shown. Hot-gas desuperheater fitting **104** is preferably cut into discharge line **110** between mechanical compressor **106** and condenser **108**, as shown. Liquid refrigerant transfer line **114** preferably couples to liquid runoff line **112** at a point preferably between condenser **108** and thermal expansion valve **124**, preferably at an elevation between about level with, to about 24 inches above, hot-gas desuperheater fitting **104**, preferably between about 12 inches and

about 24 inches above hot-gas desuperheater fitting **104**. The above described method embodies herein A method, relating to cooling at least one superheated refrigerant batch during at least one heat cycle, such method comprising the steps of: creating suction to draw at least one cooler refrigerant batch into heat exchange relationship with such at least one superheated refrigerant batch; exchanging heat between such at least one superheated refrigerant batch and at least one cooler refrigerant batch to decrease temperature differential between such at least one superheated refrigerant batch and such at least one cooler refrigerant batch and form at least one cooler superheated refrigerant batch; injecting such at least one cooler refrigerant batch into the at least one cooler superheated refrigerant batch after the step of exchanging heat; and mixing such at least one cooler refrigerant batch and such at least one cooler superheated refrigerant batch to produce at least one desuperheated refrigerant batch having at least one portion substantially near at least one saturated state. A batch being defined as a portion of the fluid as it flows through the refrigeration system.

FIG. 2 shows a longitudinal cross-sectional view through hot-gas desuperheater fitting **104** according to the preferred embodiment of FIG. 1.

Hot-gas desuperheater fitting **104** preferably comprises an outer conduit **116**, preferably defining an interior passage **118** having an interior diameter, and preferably capable of coupling to refrigerant discharge line **110**. Diameter of refrigerant discharge line **110** preferably comprises about 7/8 inch, alternately preferably about 1-1/8 inch, alternately preferably about 1-3/8 inch, alternately preferably about 1-5/8 inch, alternately preferably about 2-1/8 inch, alternately preferably about 2-5/8 inch, alternately preferably about 3-1/8 inch. Upon reading this specification, those skilled in the art will now appreciate that, under appropriate circumstances, considering such issues as future technology, size standards, regulations etc., other discharge line diameters, such as, for example, 5 cm, 7.5 cm, 3 inch, greater than 3-1/8 inch, smaller than 7/8 inch, etc., may suffice.

Outer conduit **116** preferably comprises at least one outer housing **416**, at least one intake-side coupler **418** and at least one outlet-side coupler **445**, as shown. Intake-side coupler **418** and outlet-side coupler **445** preferably adapt diameter of outer housing **416** to refrigerant discharge line **110**, as shown.

For diameters of refrigerant discharge line **110** ranging from about 7/8 inch to about 1-3/8 inches, outer diameter of outer housing **416** preferably comprises about 2-5/8 inches. For diameters of refrigerant discharge line **110** ranging from about 1-3/8 inches to about 2-5/8 inches, outer diameter of outer housing **416** preferably comprises about 3-1/8 inches. For diameters of refrigerant discharge line **110** of about 3-1/8 inches, outer diameter of outer housing

416 preferably comprises about 3-5/8 inches. Upon reading this specification, those skilled in the art will now appreciate that, under appropriate circumstances, considering such issues as future technology, manufacturing methods, regulations etc., other outer housing diameter discharge line diameter pairings, such as, for example, 7/8 inch to 2-1/8 inches, 1-3/8 inches to 1-7/8 inches, etc., may suffice.

Hot-gas desuperheater fitting **104** preferably comprises at least one Venturi structure **150**, preferably comprising at least one interior channel **120**, preferably comprising a diameter less than discharge line **110**, preferably located within interior passage **118**. Venturi structure **150** (at least embodying herein wherein said at least one heat exchanger comprises at least one suction creator structured and arranged to create suction to draw such at least one cooling fluid into said at least one heat exchanger by decreasing localized pressure near said at least one injector; and at least embodying herein wherein said heat exchanger means comprises suction creator means for creating suction to draw such at least one cooling fluid into heat exchanger means by decreasing localized pressure near said injector means), utilizing the "Venturi Effect", preferably induces the formation of at least one low-pressure region **145**, preferably within interior passage **118**, from the increased axial velocity of high-temperature superheated vapor **132** through interior channel **120**.

Outer diameter of interior channel **120**, as shown, preferably comprises between about 1/4 inch less than refrigerant discharge line **110** (for smaller diameters of refrigerant discharge line **110**) and preferably about 1/2 inch less than refrigerant discharge line **110** (for larger diameters of refrigerant discharge line **110**). More particularly, for diameter of refrigerant discharge line **110** comprising about 7/8 inch, outer diameter of interior channel **120** preferably comprises about 5/8 inch. Additionally, for diameter of refrigerant discharge line **110** preferably comprising about 1-1/8 inches, outer diameter of interior channel **120** preferably comprises about 7/8 inch. Further, for diameter of refrigerant discharge line **110** comprising about 1-5/8 inches, outer diameter of interior channel **120** preferably comprises about 1-3/8 inches. Even further, for diameter of refrigerant discharge line **110** comprising about 2-1/8 inches, outer diameter of interior channel **120** preferably comprises about 1-5/8 inches. Additionally, for diameter of refrigerant discharge line **110** comprising about 2-5/8 inches, outer diameter of interior channel **120** preferably comprises about 2-1/8 inches. Also, for diameter of refrigerant discharge line **110** comprising about 3-1/8 inches, outer diameter of interior channel **120** preferably comprises about 2-5/8 inches. Essentially, outer diameter of interior channel **120** preferably comprises about one standard size smaller than refrigerant discharge line **110** (this arrangement at least embodying herein wherein the diameter of such at least one discharge line is larger than the diameter of said

at least one suction creator). Upon reading this specification, those skilled in the art will now appreciate that, under appropriate circumstances, considering such issues as standard sizing, flow requirements, etc., other size differentials between interior channel and discharge line may suffice.

Lower-temperature liquid refrigerant **136** preferably enters hot-gas desuperheater fitting **104** through at least one side inlet **126** in fluid communication with at least one internal pre-injection chamber **122**, as shown. Side inlet **126** preferably receives lower-temperature liquid refrigerant **136** from liquid refrigerant transfer line **114** (see FIG.1), as shown. Diameter of side inlet **126** preferably comprises about 7/8 inch.

Pre-injection chamber **122** is preferably positioned circumferentially around interior channel **120**, preferably within interior passage **118**, as shown. Pre-injection chamber **122** preferably runs the length of interior channel **120**, preferably comprising between about 4 inches and about 10 inches. Length of interior channel **120** preferably comprises about 5 inches, alternately preferably about 7 inches. Upon reading this specification, those skilled in the art will now appreciate that, under appropriate circumstances, considering such issues as cost, temperature differential, refrigerant, etc., other lengths may suffice.

Pre-injection chamber **122** preferably serves to provide an initial heat exchange between lower-temperature liquid refrigerant **136** and high-temperature vapor **140**, preferably through the wall of interior channel **120** (at least embodying herein at least one heat exchanger structured and arranged to exchange heat between at least one cooling fluid and the at least one superheated refrigerant fluid, to decrease temperature differential between such at least one cooling fluid and such at least one superheated refrigerant fluid; and at least embodying herein heat exchanger means for exchanging heat between at least one cooling fluid and the at least one superheated refrigerant fluid, to decrease temperature differential between such at least one cooling fluid and the at least one superheated refrigerant fluid). The wall of interior channel **120** (at least embodying herein wherein at least one wall of said at least one suction creator comprises at least one separator structured and arranged to physically separate such at least one cooler fluid from the at least one superheated refrigerant fluid, while allowing exchange of heat in said at least one heat exchanger by transmitting heat through said at least one separator) preferably prevents the immediate mixing of lower-temperature liquid refrigerant **136** with high-temperature vapor **140**, preferably allowing initial heat exchange to diminish the temperature variation between lower-temperature liquid refrigerant **136** and high-temperature vapor **140**. This initial heat exchange preferably begins vaporization of lower-temperature liquid refrigerant **136**, preferably prior to injection, preferably allowing rapid mixing, of lower-temperature liquid refrigerant **136** with

high-temperature vapor **140** preferably without thermal shock (this arrangement at least embodying herein exchanging heat, in at least one heat exchanger, between at least one cooling fluid and the at least one superheated refrigerant fluid, to decrease temperature differential between such at least one cooling fluid and the at least one superheated refrigerant fluid).

At least two spacers **425** preferably axially center interior channel **120** inside interior passage **118**, as shown. Spacers **425** preferably define spacing of internal pre-injection chamber **122**, as shown. Spacer **425**, near inlet side of hot-gas desuperheater fitting **104**, preferably comprises at least one sealing spacer **426**, as shown, preferably sealing against passage of high-temperature vapor **140** into internal pre-injection chamber **122**, thereby preferably forcing flow of high-temperature vapor **140** into interior channel **120** (this arrangement at least embodies herein wherein the at least one superheated refrigerant fluid flows inside said at least one tube and such at least one cooler fluid may substantially surround the exterior perimeter of said at least one tube). Spacer **425**, near outlet side of hot-gas desuperheater fitting **104**, as shown, preferably comprises at least one injection portal spacer **428**, as shown, preferably allowing passage of lower-temperature liquid refrigerant **136** into interior passage **118** from internal pre-injection chamber **122** (this arrangement at least embodies herein injecting, using at least one injector, such at least one cooling fluid into the at least one superheated refrigerant fluid after the step of exchanging heat).

Pre-ejection chamber **122** preferably uniformly distributes the liquid refrigerant around interior channel **120** prior to downstream discharge into interior passage **118**. In preferred operation, lower temperature liquid refrigerant **136** is passively suctioned from liquid runoff line **112**, preferably through liquid refrigerant transfer line **114**, and is preferably injected into discharge line **110** at hot-gas desuperheater fitting **104**, as shown.

Low-pressure region **145** preferably forms, as shown, preferably at the exit of Venturi structure **150** due to the Venturi Effect (this arrangement at least embodies herein creating suction to draw such at least one cooling fluid into such at least one heat exchanger by decreasing localized pressure near such at least one injector). Lower-temperature liquid refrigerant **136** is preferably drawn, by low-pressure region **145**, preferably from pre-injection chamber **122** into interior channel **120**, preferably through at least one injection port **128** (at least embodying herein wherein said at least one injector comprises at least one injector port) preferably passing through injection portal spacer **428** (at least embodying herein at least one injector structured and arranged to inject such at least one cooling fluid into the at least one superheated refrigerant fluid after exchange of heat in said at least one heat exchanger; and at least embodying herein injector means for injecting such at least one cooling fluid into the at

least one superheated refrigerant fluid after exchange of heat in said at least one heat exchanger) near the exit of interior channel **120**, as shown. This arrangement at least embodies herein wherein said at least one suction creator assists injection by said at least one injector; and this arrangement at least embodies herein wherein such suction assists injection by such at least one injector; and this arrangement at least embodies herein wherein said suction creator means assists injection by said injector means.

Additionally, at least one mixing chamber **450** preferably uses turbulence, at the exit of interior channel **120**, to inject lower-temperature liquid refrigerant **136** preferably around the entire circumference of interior passage **118** (this arrangement at least embodies herein mixing such injected cooling fluid and the at least one superheated refrigerant fluid to produce at least one desuperheated refrigerant fluid having at least one state substantially near at least one saturated state).

In the depicted preferred embodiment of the present invention, lower-temperature liquid refrigerant **136** injects through preferably about eight injection ports **128** (at least embodying herein wherein said at least one injector comprises a plurality of said at least one injector ports evenly spaced about the perimeter of the flow of the at least one superheated refrigerant fluid), preferably evenly spaced, arranged circumferentially about interior channel **120**, as shown in FIG. 3, thus preferably maximizing mixing and preferably injection efficiency in mixing chamber **450** (at least embodying herein at least one fluid mixer structured and arranged to mix such injected cooling fluid and the at least one superheated refrigerant fluid to produce at least one desuperheated refrigerant fluid having at least one state substantially near at least one saturated state; and this arrangement at least embodying herein wherein said at least one injector injects such at least one cooler fluid into the at least one superheated refrigerant fluid substantially evenly around the perimeter of flow of the at least one superheated refrigerant fluid; and at least embodying herein fluid mixer means for mixing such injected cooling fluid and the at least one superheated refrigerant fluid to produce at least one desuperheated refrigerant fluid having at least one state substantially near at least one saturated state). As a result, high-temperature vapor **140**, which had previously been above the saturation temperature (high-temperature superheated vapor **132**), is preferably brought near to the saturation temperature (becoming high-temperature desuperheated vapor **134**), as shown. Saturation temperature is the temperature at which a gas begins to condense into a liquid.

Hot-gas desuperheater fitting **104** is preferably atmosphere-tight bonded silver soldered to form an assembly, as shown. Further, hot-gas desuperheater fitting **104** is preferably atmosphere-tight bonded silver soldered to discharge line **110** and liquid refrigerant transfer line

114, when installed. Upon reading this specification, those skilled in the art will now appreciate that, under appropriate circumstances, considering such issues as future materials, thermal expansion variations, etc., other atmosphere tight bondings, may suffice.

Hot-gas desuperheater fitting **104** preferably is installed vertically with outlet-side coupler **445** higher in elevation than **418**. This vertical arrangement preferably allows lower-temperature liquid **136** to preferably pool in internal pre-injection chamber **122**, preferably allowing for the initial heat exchange prior to injection.

It is noted that hot-gas desuperheater circuit **102** preferably does not require a mechanical pump or gravity-assisted fluid pressure to operate. Rather, hot-gas desuperheater circuit **102** preferably uses the Venturi Effect to create suction. Further, hot-gas desuperheater circuit **102** preferably does not require injecting fluids from sources external to refrigeration cycle **101**. Rather, hot-gas desuperheater circuit **102** preferably utilizes a portion of lower-temperature liquid refrigerant **136** already in refrigeration cycle **101**, as shown.

Additionally, by using both the initial heat exchange and injecting lower-temperature liquid **136**, less of lower-temperature liquid **136** is preferably needed to desuperheat high-temperature vapor **140**. Since any amount of lower-temperature liquid **136** diverted from refrigeration cycle **101** results in reduced efficiency of refrigeration cycle **101**, utilizing less of lower-temperature liquid **136** decreases loss of efficiency required to extend the life of condenser **108**.

Also, applicant has determined, through testing, that temperatures of high-temperature superheated vapor **132** in refrigeration cycle **101**, running about 190 degrees Fahrenheit, were reduced to about 90 degrees Fahrenheit in high-temperature desuperheated vapor **134**.

Further, applicant has determined, through testing, that hot-gas desuperheater fitting **104** self-regulates the amount of lower-temperature liquid **136** injected based on the volume of high-temperature superheated vapor **132** flowing through hot-gas desuperheater fitting **104**. When the flow volume of high-temperature superheated vapor **132** decreases the suction created by Venturi structure **150** likewise decreases drawing less of lower-temperature liquid **136** into internal pre-injection chamber **122**. This behavior allows hot-gas desuperheater fitting **104** to adjust, in multi-loop heating systems, to changes in flow of high-temperature superheated vapor **132** caused by a loop shutting off or running in defrost mode. By self-regulating, high-temperature superheated vapor **132** is not over-cooled but maintains approximately the same cooling rate.

FIG. 3 shows an exploded view of hot-gas desuperheater fitting **104** of FIG. 2. As shown, intake-side coupler **418** and outlet-side coupler **445** preferably comprise diameter-reducing couplers sized to couple discharge line **110** and outer housing **416**. Outer housing **416**

(at least embodying herein wherein said at least one outer container is substantially cylindrical) preferably comprises at least one cylinder, preferably at least one section of pipe, comprising sizes as discussed in relation to FIG. 2. Likewise, interior channel **120** (at least embodying herein wherein said at least one suction creator comprises at least one tube; and at least embodying herein wherein said at least one suction creator is substantially cylindrical) and side inlet **126** preferably each comprise, as shown, at least one cylinder, preferably at least one section of pipe, comprising sizes as discussed in relation to FIG. 2. Intake-side coupler **418**, outlet-side coupler **445** (at least embodying herein at least one discharge line adapter structured and arranged to adapt the perimeter of at least one discharge line, from at least one compressor, to the perimeter of said at least one outer container), outer housing **416** (at least embodying herein at least one outer container structured and arranged to contain such at least one cooler fluid substantially near said at least one separator), interior channel **120**, and side inlet **126** preferably comprise metal, preferably copper. Upon reading this specification, those skilled in the art will now appreciate that, under appropriate circumstances, considering such issues as future materials, equipment integrated with, thermal expansion variations, etc., other materials, such as for example, ceramets, metal alloys, future plastics, other than copper metals, etc., may suffice.

Spacers **425** preferably comprise at least one ring preferably with at least one inner diameter substantially matching the outer diameter of interior channel **120** and at least one outer diameter preferably substantially matching interior diameter of outer housing **416**, as shown. Injection portal spacer **428** preferably further comprises injection ports **128**, preferably between about 1/8 inch and about 1/2 inch in diameter (at least embodying herein wherein the diameter of said at least one injector port comprises between about 1/8 inch and about 1/2 inch).

Diameter of injection ports **128** preferably comprises about 1/4 inch (at least embodying herein wherein the diameter of said at least one injector port comprises about 1/4 inch), alternately preferably about 3/8 inch (at least embodying herein wherein the diameter of said at least one injector port comprises about 3/8 inch).

Variation in diameter of injection ports **128** may preferably be used to control the rate of lower-temperature liquid **136** injected. Upon reading this specification, those skilled in the art will now appreciate that, under appropriate circumstances, considering such issues as fitting sizes, cost, flow rates, etc., other injection port diameters, may suffice.

In selecting the number and size of injection ports **128**, the diameter of injection ports **128** times the number of injection ports **128** preferably comprises approximately the diameter of

discharge line **110**. Applicant has theorized that this relationship achieves optimal injection rates.

Spacers **425** preferably comprise metal, preferably brass. Upon reading this specification, those skilled in the art will now appreciate that, under appropriate circumstances, considering such issues as future materials, equipment integrated with, thermal expansion variations, etc., other materials, such as for example, ceramics, other than brass metal alloys, future plastics, other metals, etc., may suffice.

In order to make installation and use easier, intake-side coupler **418** and outlet-side coupler **445** preferably further comprise at least one temperature indicator **435**, as shown, preferably indicia **438**, preferably indicating the “hot” side and the “cool” side of hot-gas desuperheater fitting **104**, preferably effectively indicating flow direction across hot-gas desuperheater fitting **104**, as shown. Temperature indicator **435** preferably comprises at least one color indicator, preferably red on the “hot” side and blue on the “cool” side. For purposes of illustration, FIG. 3 denotes preferred such at least one color indicator with the characters “H” and “C”, as shown. Upon reading this specification, those skilled in the art will now appreciate that, under appropriate circumstances, considering such issues as industry regulations, cost, manufacturing methods, etc., other temperature variation indicators, such as, for example, characters, symbols, graphics, color patterns, etc., may suffice.

FIG. 4 shows a schematic diagram illustrating the primary components of a refrigeration cycle **501** utilizing at least one defrosting injection circuit according to another preferred embodiment of the present invention. Although most features of Hot-gas desuperheater circuit **402** are repeated from preferred Hot-gas desuperheater circuit **102**, in Hot-gas desuperheater circuit **402**, rather than transferring high-temperature desuperheated vapor **134** to condenser **108**, high-temperature desuperheated vapor **134** is preferably used to defrost evaporator **146**, as shown.

Hot-gas desuperheater fitting **104** is preferably also useful in providing improved hot-gas defrosting, which may be used on a single or multiple evaporator system, and is particularly useful on multiplexed systems with evaporators at different temperatures. In this preferred embodiment, high-temperature vapor **140** is preferably routed to the outlet of evaporator **146**, as shown. This preferably warms evaporator **146** to thaw any frost that has accumulated.

Defrost cycle **401** preferably uses at least one solenoid valve **406** and at least one solenoid valve **444** to reverse fluid flow across evaporator **146**, as shown. Solenoid valve **444** preferably opens to allow flow of high-temperature vapor **140** to outlet-side of evaporator **146**, while solenoid valve **406** preferably closes to prevent flow of high-temperature vapor **140** back

into mechanical compressor **106**. Likewise, at least one check valve **424** preferably bypasses expansion valve **124**, as shown.

High-temperature vapor **140** preferably flows through evaporator **146**, as shown, exchanging heat to defrost evaporator **146**, and preferably condenses to form lower-temperature liquid **136**. Lower-temperature liquid **136** preferably bypasses expansion valve **124**, using check valve **424**, and feeds back into liquid runoff line **112**, as shown. By using hot-gas desuperheater fitting **104** in defrost cycle **401**, thermal shock preferably is significantly reduced on evaporator **146**, which preferably leads to a longer life of evaporator **146**.

FIG. 5 shows a longitudinal cross-sectional view through another hot-gas desuperheater fitting **504** according to an alternately preferred embodiment of the present invention. Although most features of hot-gas desuperheater fitting **504** are repeated from preferred hot-gas desuperheater fitting **104**, in hot-gas desuperheater fitting **504**, rather than spacers **425**, at least two spacers **525** are preferably used to reduce the diameter, as shown.

Spacer **525** preferably comprises at least one diameter-reducing coupler, as shown. Spacer **525** preferably comprises metal, preferably copper. Upon reading this specification, those skilled in the art will now appreciate that, under appropriate circumstances, considering such issues as future materials, equipment integrated with, thermal expansion variations, etc., other materials, such as for example, ceremets, metal alloys, future plastics, other than copper metals, etc., may suffice.

Injection portal spacer **545**, similarly to injection portal spacer **428**, preferably comprises at least one injection port **528**, preferably eight injection ports **528**, preferably substantially similar to injection port **128** in size and distribution. Injection port **528** preferably is preferably positioned on beveled portion of injection portal spacer **545**, as shown.

Sealing spacer **526**, similarly to sealing spacer **426**, preferably seals off internal pre-injection chamber **122** at inlet-side of interior channel **120**. Sealing spacer **526**, however, also provides a beveled entrance to interior channel **120** for flow of high-temperature vapor **140**.

Although applicant has described applicant's preferred embodiments of this invention, it will be understood that the broadest scope of this invention includes modifications such as diverse shapes, sizes, and materials. Such scope is limited only by the below claims as read in connection with the above specification. Further, many other advantages of applicant's invention will be apparent to those skilled in the art from the above descriptions and the below claims.

WHAT IS CLAIMED IS:

- 1) A system, relating to cooling at least one superheated refrigerant fluid during at least one heat cycle, such system comprising:
 - a) at least one heat exchanger structured and arranged to exchange heat between at least one cooling fluid and the at least one superheated refrigerant fluid to decrease temperature differential between such at least one cooling fluid and such at least one superheated refrigerant fluid;
 - b) at least one injector, structured and arranged to inject such at least one cooling fluid into the at least one superheated refrigerant fluid after exchange of heat in said at least one heat exchanger; and
 - c) at least one fluid mixer structured and arranged to mix such injected cooling fluid and the at least one superheated refrigerant fluid to produce at least one desuperheated refrigerant fluid having at least one state substantially near at least one saturated state;
 - d) wherein said at least one heat exchanger comprises at least one suction creator structured and arranged to create suction to draw such at least one cooling fluid into said at least one heat exchanger by decreasing localized pressure near said at least one injector; and
 - e) wherein said at least one suction creator assists injection by said at least one injector.
- 2) The system according to claim 1 wherein said at least one suction creator comprises at least one separator structured and arranged to physically separate such at least one cooling fluid from the at least one superheated refrigerant fluid, while allowing exchange of heat in said at least one heat exchanger by transmitting heat through said at least one separator.
- 3) The system according to claim 2 wherein said at least one suction creator comprises at least one tube.
- 4) The system according to claim 3 wherein said at least one tube is structured and arranged to:
 - a) contain flow of the at least one superheated refrigerant fluid inside said at least one tube; and
 - b) separate flow of such at least one cooling fluid substantially around at least one perimeter of said at least one tube.

- 5) The system according to claim 4 wherein said at least one injector is structured and arranged to inject such at least one cooling fluid into the at least one superheated refrigerant fluid substantially evenly around at least one perimeter of flow of the at least one superheated refrigerant fluid.
- 6) The system according to claim 4 wherein said at least one injector comprises at least one injector port.
- 7) The system according to claim 6 wherein said at least one injector comprises a plurality of said at least one injector ports evenly spaced about the perimeter of the flow of the at least one superheated refrigerant fluid.
- 8) The system according to claim 7 wherein, when connected to at least one discharge line, the diameter of said at least one injector port multiplied by the quantity of said plurality of said at least one injection ports comprises about the diameter of at least one discharge line
- 9) The system according to claim 7 wherein the diameter of said at least one injector port comprises between about 1/8 inch and about 1/2 inch.
- 10) The system according to claim 9 wherein the diameter of said at least one injector port comprises about 3/8 inch.
- 11) The system according to claim 9 wherein the diameter of said at least one injector port comprises about 1/4 inch.
- 12) The system according to claim 4 further comprising at least one outer container structured and arranged to contain such at least one cooling fluid substantially near said at least one separator.
- 13) The system according to claim 12 further comprising at least one discharge line structured and arranged to fit at least one discharge line.
- 14) The system according to claim 13 wherein said at least one suction creator is substantially cylindrical.
- 15) The system according to claim 13 wherein said at least one outer container is substantially cylindrical.
- 16) The system according to claim 15 wherein the difference between the diameter of such at least one discharge line and the diameter of said at least one suction creator comprises between about 1/2 inch and about 1/4 inch.
- 17) The system according to claim 16 wherein the difference between the diameter of said at least one outer container and the diameter of said at least one suction creator comprises between about 2 inches and about 1 inch.

- 18) The system according to claim 17 wherein the diameter of said at least one outer container comprises about 2-5/8 inches.
- 19) The system according to claim 18 wherein the diameter of such at least one discharge line comprises about 7/8 inches.
- 20) The system according to claim 19 wherein the diameter of said at least one suction creator comprises about 5/8 inches.
- 21) The system according to claim 18 wherein the diameter of such at least one discharge line comprises about 1-1/8 inches.
- 22) The system according to claim 21 wherein the diameter of said at least one suction creator comprises about 7/8 inches.
- 23) The system according to claim 17 wherein the diameter of such at least one discharge line comprises about 1-3/8 inches.
- 24) The system according to claim 23 wherein the diameter of said at least one suction creator comprises about 1-1/8 inches.
- 25) The system according to claim 17 wherein the diameter of said at least one outer container comprises about 3-1/8 inches.
- 26) The system according to claim 25 wherein the diameter of such at least one discharge line comprises about 1-5/8 inches.
- 27) The system according to claim 26 wherein the diameter of said at least one suction creator comprises about 1-3/8 inches.
- 28) The system according to claim 25 wherein the diameter of such at least one discharge line comprises about 2-1/8 inches.
- 29) The system according to claim 28 wherein the diameter of said at least one suction creator comprises about 1-5/8 inches.
- 30) The system according to claim 25 wherein the diameter of such at least one discharge line comprises about 2-5/8 inches.
- 31) The system according to claim 30 wherein the diameter of said at least one suction creator comprises about 2-1/8 inches.
- 32) The system according to claim 17 wherein the diameter of said at least one outer container comprises about 3-5/8 inches.
- 33) The system according to claim 32 wherein the diameter of such at least one discharge line comprises about 3-1/8 inches.
- 34) The system according to claim 33 wherein the diameter of said at least one suction creator comprises about 2-5/8 inches.

- 35) The system according to claim 1 wherein said at least one injector comprises metal.
- 36) The system according to claim 35 wherein said at least one injector comprises brass.
- 37) The system according to claim 35 wherein said at least one injector comprises copper.
- 38) The system according to claim 1 wherein said at least one heat exchanger comprises metal.
- 39) The system according to claim 38 wherein said at least one heat exchanger comprises copper.
- 40) A method, relating to cooling at least one superheated refrigerant fluid during at least one heat cycle, such method comprising the steps of:
 - a) exchanging heat, in at least one heat exchanger, between at least one cooling fluid and the at least one superheated refrigerant fluid to decrease temperature differential between such at least one cooling fluid and the at least one superheated refrigerant fluid;
 - b) injecting, using at least one injector, such at least one cooling fluid into the at least one superheated refrigerant fluid after the step of exchanging heat;
 - c) mixing such injected cooling fluid and the at least one superheated refrigerant fluid to produce at least one desuperheated refrigerant fluid having at least one state substantially near at least one saturated state; and
 - d) creating suction to draw such at least one cooling fluid into such at least one heat exchanger by decreasing localized pressure near such at least one injector;
 - e) wherein such suction assists injection by such at least one injector.
- 41) A system, relating to cooling at least one superheated refrigerant during at least one heat cycle, such system comprising:
 - a) heat exchanger means for exchanging heat between at least one cooling fluid and the at least one superheated refrigerant fluid to decrease temperature differential between such at least one cooling fluid and the at least one superheated refrigerant fluid;
 - b) injector means for injecting such at least one cooling fluid into the at least one superheated refrigerant fluid after exchange of heat in said at least one heat exchanger;
 - c) fluid mixer means for mixing such injected cooling fluid and the at least one superheated refrigerant fluid to produce at least one desuperheated refrigerant fluid having at least one state substantially near at least one saturated state;

- d) wherein said heat exchanger means comprises suction creator means for creating suction to draw such at least one cooling fluid into said heat exchanger means by decreasing localized pressure near said injector means; and
 - e) wherein said suction creator means assists injection by said injector means.
- 42) A method, relating to cooling at least one superheated refrigerant batch during at least one heat cycle, such method comprising the steps of:
- a) creating suction to draw at least one cooler refrigerant batch into heat exchange relationship with such at least one superheated refrigerant batch;
 - b) exchanging heat between such at least one superheated refrigerant batch and at least one cooler refrigerant batch to decrease temperature differential between such at least one superheated refrigerant batch and such at least one cooler refrigerant batch and form at least one cooler superheated refrigerant batch;
 - c) injecting such at least one cooler refrigerant batch into the at least one cooler superheated refrigerant batch after the step of exchanging heat; and
 - d) mixing such at least one cooler refrigerant batch and such at least one cooler superheated refrigerant batch to produce at least one desuperheated refrigerant batch having at least one portion substantially near at least one saturated state.

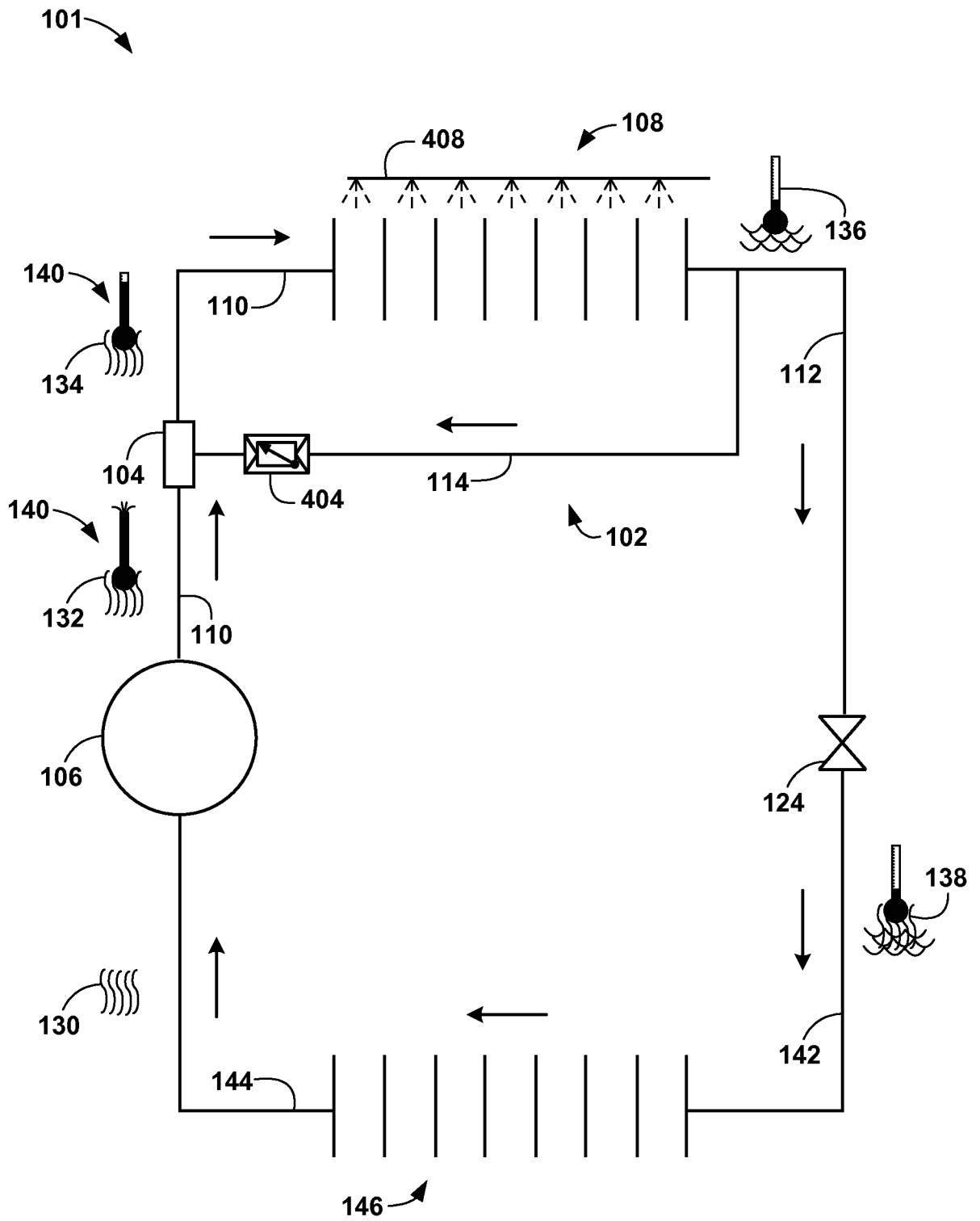

FIG. 1

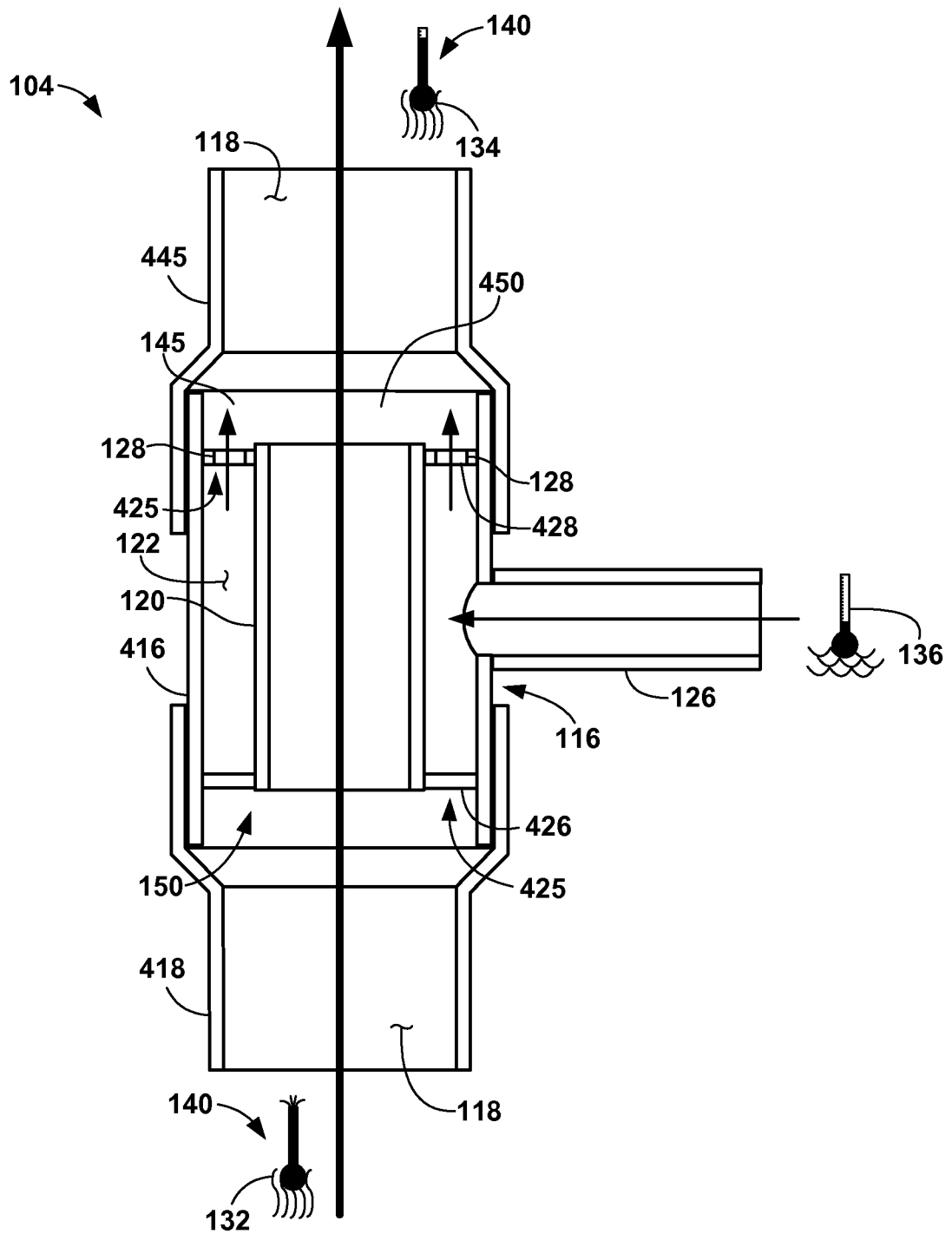

FIG. 2

3/5

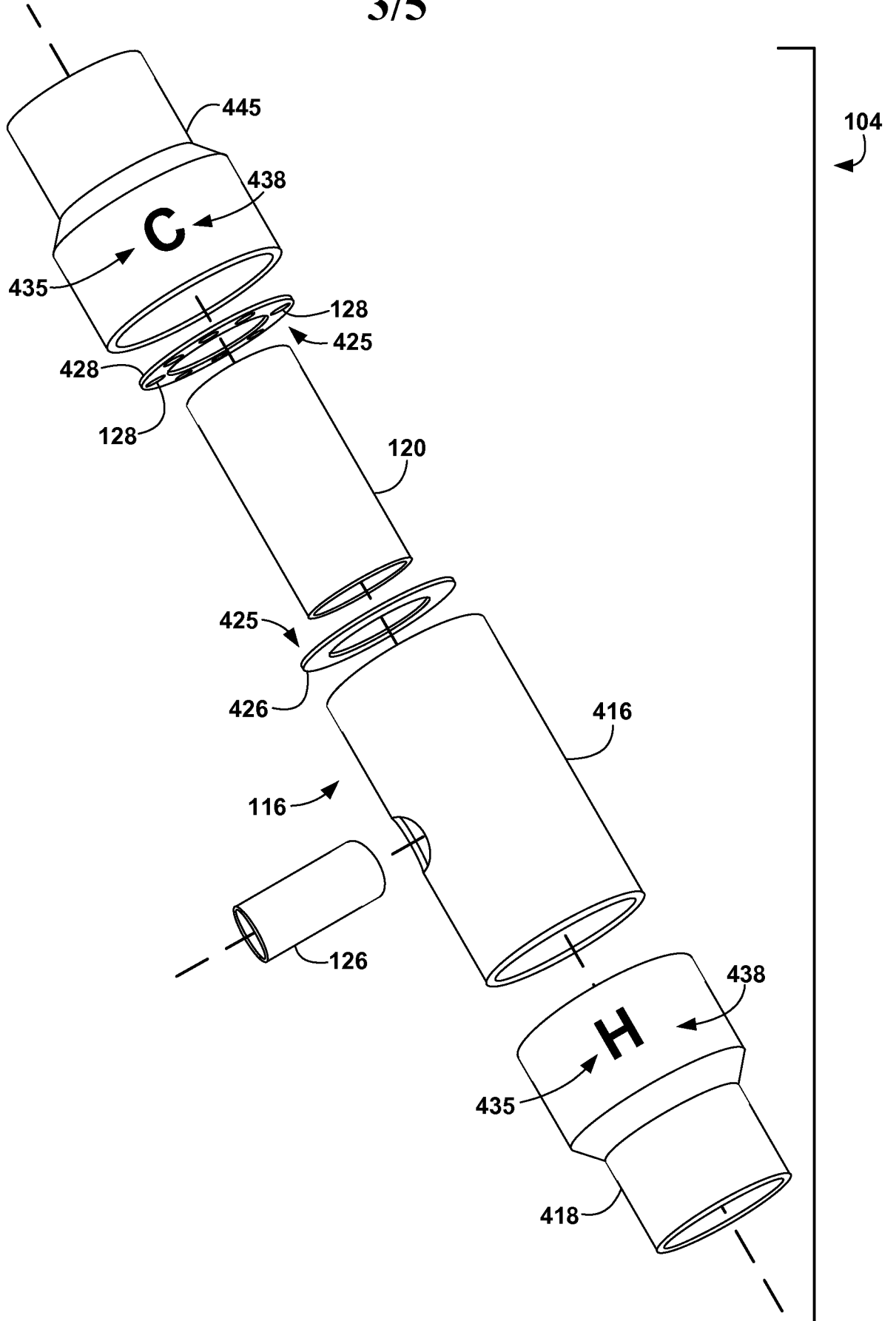

FIG. 3

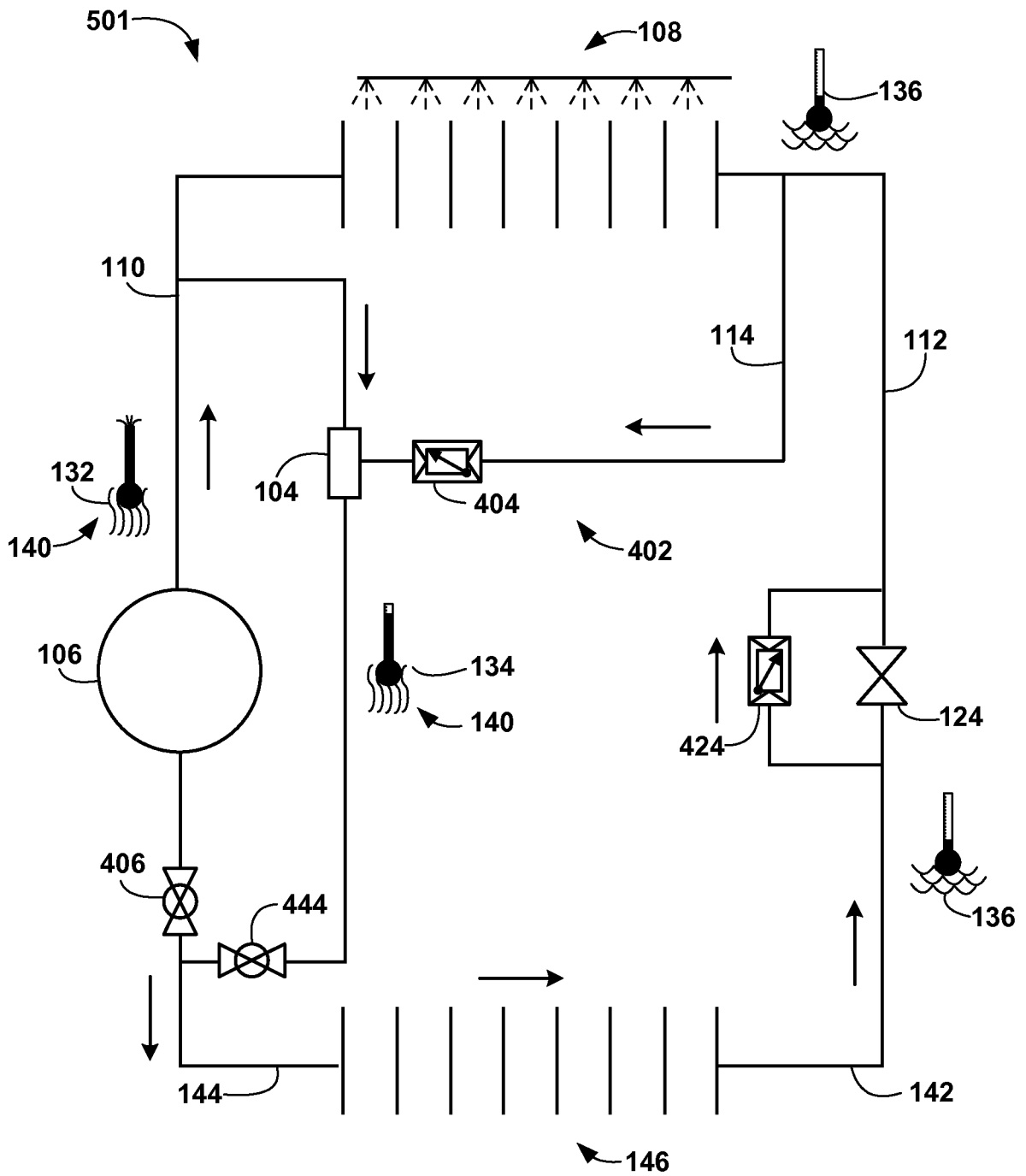

FIG. 4

